

# SUPERO<sup>®</sup>

## SC819 Chassis Series

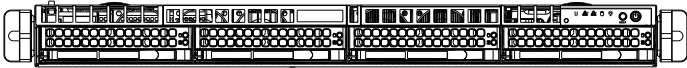

SC819TQ-R700UB

SC819TQ-R700WB

## USER'S MANUAL

1.0b

The information in this User's Manual has been carefully reviewed and is believed to be accurate. The vendor assumes no responsibility for any inaccuracies that may be contained in this document, makes no commitment to update or to keep current the information in this manual, or to notify any person or organization of the updates. **Please Note: For the most up-to-date version of this manual, please see our web site at [www.supermicro.com](http://www.supermicro.com).**

Super Micro Computer, Inc. ("Supermicro") reserves the right to make changes to the product described in this manual at any time and without notice. This product, including software and documentation, is the property of Supermicro and/or its licensors, and is supplied only under a license. Any use or reproduction of this product is not allowed, except as expressly permitted by the terms of said license.

IN NO EVENT WILL SUPERMICRO BE LIABLE FOR DIRECT, INDIRECT, SPECIAL, INCIDENTAL, SPECULATIVE OR CONSEQUENTIAL DAMAGES ARISING FROM THE USE OR INABILITY TO USE THIS PRODUCT OR DOCUMENTATION, EVEN IF ADVISED OF THE POSSIBILITY OF SUCH DAMAGES. IN PARTICULAR, SUPERMICRO SHALL NOT HAVE LIABILITY FOR ANY HARDWARE, SOFTWARE, OR DATA STORED OR USED WITH THE PRODUCT, INCLUDING THE COSTS OF REPAIRING, REPLACING, INTEGRATING, INSTALLING OR RECOVERING SUCH HARDWARE, SOFTWARE, OR DATA.

Any disputes arising between manufacturer and customer shall be governed by the laws of Santa Clara County in the State of California, USA. The State of California, County of Santa Clara shall be the exclusive venue for the resolution of any such disputes. Super Micro's total liability for all claims will not exceed the price paid for the hardware product.

California Best Management Practices Regulations for Perchlorate Materials: This Perchlorate warning applies only to products containing CR (Manganese Dioxide) Lithium coin cells. "Perchlorate Material-special handling may apply. See [www.dtsc.ca.gov/hazardouswaste/perchlorate](http://www.dtsc.ca.gov/hazardouswaste/perchlorate)"

---

**WARNING: Handling of lead solder materials used in this product may expose you to lead, a chemical known to the State of California to cause birth defects and other reproductive harm.**

---

Manual Revision 1.0b  
Release Date: July 17, 2013

Unless you request and receive written permission from Super Micro Computer, Inc., you may not copy any part of this document.

Information in this document is subject to change without notice. Other products and companies referred to herein are trademarks or registered trademarks of their respective companies or mark holders.

Copyright © 2013 by Super Micro Computer, Inc.  
All rights reserved.

**Printed in the United States of America**

---

## Preface

### About This Manual

This manual is written for professional system integrators and PC technicians. It provides information for the installation and use of the SC819 1U chassis. Installation and maintenance should be performed by experienced technicians only.

Supermicro's SC819 1U chassis features a unique and highly-optimized design for 1U UIO servers. The chassis is equipped with a 700W high-efficiency 80 Plus Gold Level certified power supply to support high-performance system components and high-speed heavy-duty counter rotating fans for ample cooling. The chassis provides maximum features in a 1U form factor for high-end, high-performance applications.

## Manual Organization

### **Chapter 1 Introduction**

The first chapter provides a list of the main components included with this chassis and describes the main features of the SC819 chassis. This chapter also includes contact information.

### **Chapter 2 Standardized Warning Statements for AC Systems**

This chapter lists warnings, precautions, and system safety. You should thoroughly familiarize yourself with this chapter for a general overview of safety precautions that should be followed before installing and servicing this chassis.

### **Chapter 3 Chassis Components**

Refer here for details on this chassis model including the fans, drive bays, airflow shrouds, and other components.

### **Chapter 4 System Interface**

Refer to this chapter for details on the system interface, which includes the functions and information provided by the control panel on the chassis as well as other LEDs located throughout the system.

### **Chapter 5 Chassis Setup and Installation**

This chapter provides detailed information on this chassis. You should follow the procedures given in this chapter when installing, removing, or reconfiguring your chassis.

### **Chapter 6 Rack Installation**

Refer to this chapter for detailed information on chassis rack installation. You should follow the procedures given in this chapter when installing, removing or reconfiguring your chassis into a rack environment.

### **Appendices**

This section lists compatible cables, power supply specifications, and compatible backplanes. Not all compatible backplanes are listed. Refer to our web site for the latest compatible backplane information.

#### **Appendix A Chassis Cables**

#### **Appendix B Power Supply Specifications**

#### **Appendix C SAS-815TQ Backplane Specifications**

# Table of Contents

## **Preface**

About This Manual .....	iii
-------------------------	-----

## **Chapter 1 Introduction**

1-1 Overview .....	1-1
1-2 Shipping List.....	1-1
1-3 Chassis Features .....	1-2
CPU.....	1-2
Hard Drives .....	1-2
I/O Expansion slots .....	1-2
Peripheral Drives.....	1-2
Other Features .....	1-2
1-4 Contacting Supermicro.....	1-3
1-5 Returning Merchandise for Service.....	1-4

## **Chapter 2 Standardized Warning Statements for AC Systems**

2-1 About Standardized Warning Statements.....	2-1
Warning Definition .....	2-1
Installation Instructions.....	2-4
Circuit Breaker .....	2-5
Power Disconnection Warning .....	2-6
Equipment Installation.....	2-8
Restricted Area.....	2-9
Battery Handling.....	2-10
Redundant Power Supplies .....	2-12
Backplane Voltage .....	2-13
Comply with Local and National Electrical Codes .....	2-14
Product Disposal .....	2-15
Hot Swap Fan Warning.....	2-16
Power Cable and AC Adapter .....	2-18

## **Chapter 3 Chassis Components**

3-1 Overview .....	3-1
3-2 Components .....	3-1
Backplane.....	3-1
Fans .....	3-1
Mounting Rails .....	3-1

Power Supply .....	3-2
Air Shroud (Optional) .....	3-2
3-3 Where to get Replacement Components .....	3-2

### **Chapter 4 System Interface**

4-1 Overview .....	4-1
4-2 Control Panel Buttons .....	4-2
4-3 Control Panel LEDs .....	4-3
4-4 Drive Carrier LEDs .....	4-5
SAS/SATA Drives .....	4-5
4-5 Power Supply LEDs and Overheat Indicators .....	4-5
4-6 Overheating .....	4-6

### **Chapter 5 Chassis Setup and Maintenance**

5-1 Overview .....	5-1
5-2 Removing the Chassis Cover .....	5-2
5-3 Installing Hard Drives .....	5-3
5-4 DVD and USB COM Tray Installation .....	5-6
5-5 Installing the Motherboard .....	5-7
Permanent and Optional Standoffs .....	5-7
Expansion Card Setup .....	5-9
5-6 Installing the Air Shroud (Optional) .....	5-11
5-7 System Fans .....	5-12
5-8 Power Supply .....	5-14
Power Supply Failure .....	5-14
5-9 Routing the I <sup>2</sup> C Cables .....	5-15

### **Chapter 6 Rack Installation**

6-1 Overview .....	6-1
6-2 Unpacking the System .....	6-1
6-3 Preparing for Setup .....	6-1
Choosing a Setup Location .....	6-1
Rack Precautions .....	6-2
General Server Precautions .....	6-2
Rack Mounting Considerations .....	6-3
Ambient Operating Temperature .....	6-3
Reduced Airflow .....	6-3
Mechanical Loading .....	6-3
Circuit Overloading .....	6-3
Reliable Ground .....	6-3
6-4 Rack Mounting Instructions .....	6-4
Identifying the Sections of the Rail Assemblies .....	6-4

---

Optional Inner Rail Extensions .....	6-5
<b><i>Appendix A Chassis Cables</i></b>	
<b><i>Appendix B SC819 Power Supply Specifications</i></b>	
<b><i>Appendix C SAS-815TQ Backplane Specifications</i></b>	

## Notes



# Chapter 1

## Introduction

### 1-1 Overview

Supermicro's SC819 1U chassis features a unique and highly-optimized design. The chassis is equipped with a high-efficiency power supply. High-performance fans provide ample optimized cooling for the chassis and four hot-swappable drive bays offer maximum storage capacity in a 1U form factor.

### 1-2 Shipping List

Please visit the Supermicro web site at [www.supermicro.com](http://www.supermicro.com) for the latest shipping lists and part numbers for your particular chassis model.

SC819 Chassis			
Model	HDD	I/O Slots	Power Supply
SC819TQ-R700UB	4x SAS / SATA	2x FH + 1x LP	700W (Gold Level)
SC819TQ-R700WB	4x SAS / SATA	2x FH + 1x LP	700W (Gold Level)
<b>Legend</b> FH = Full-height, full-length LP = Low-profile FF = Full-height, full-length			

## 1-3 Chassis Features

The SC819 1U high-performance chassis includes the following features:

### **Motherboards**

The SC819 chassis supports a single or dual processor motherboard. Please refer to the motherboard specifications pages on our website for updates on supported motherboards.

### **Hard Drives**

The SC819 chassis features four bays for SAS/SATA drives. These drives are hot-swappable. Once set up correctly, these drives can be removed without powering down the server. Additionally, these drives support SES2.

### **PCI Expansion Slots**

Each version of the SC819 chassis includes two full-height, full-length PCI expansion slots and one low-profile PCI expansion slot. "U" and "W" versions are optimized for UIO and WIO motherboards.

### **Peripheral Drives**

Each SC819 chassis supports one slim DVD-ROM drive (optional) and one slim USB COM tray (optional).

### **Other Features**

Other onboard features are included to promote system health. These include various six cooling fans, a convenient power switch, reset button, and LED indicators.

## 1-4 Contacting Supermicro

### Headquarters

Address: Super Micro Computer, Inc.  
980 Rock Ave.  
San Jose, CA 95131 U.S.A.

Tel: +1 (408) 503-8000

Fax: +1 (408) 503-8008

Email: [marketing@supermicro.com](mailto:marketing@supermicro.com) (General Information)  
[support@supermicro.com](mailto:support@supermicro.com) (Technical Support)

Web Site: [www.supermicro.com](http://www.supermicro.com)

### Europe

Address: Super Micro Computer B.V.  
Het Sterrenbeeld 28, 5215 ML  
's-Hertogenbosch, The Netherlands

Tel: +31 (0) 73-6400390

Fax: +31 (0) 73-6416525

Email: [sales@supermicro.nl](mailto:sales@supermicro.nl) (General Information)  
[support@supermicro.nl](mailto:support@supermicro.nl) (Technical Support)  
[rma@supermicro.nl](mailto:rma@supermicro.nl) (Customer Support)

### Asia-Pacific

Address: Super Micro Computer, Inc.  
3F, No. 150, Jian 1st Rd.  
Zhonghe Dist., New Taipei City 23511  
Taiwan (R.O.C)

Tel: +886-(2) 8226-3990

Fax: +886-(2) 8226-3992

Web Site: [www.supermicro.com.tw](http://www.supermicro.com.tw)

Technical Support:

Email: [support@supermicro.com.tw](mailto:support@supermicro.com.tw)

Tel: +886-(2)-8226-3990

## 1-5 Returning Merchandise for Service

A receipt or copy of your invoice marked with the date of purchase is required before any warranty service will be rendered. You can obtain service by calling your vendor for a Returned Merchandise Authorization (RMA) number. When returning to the manufacturer, the RMA number should be prominently displayed on the outside of the shipping carton, and mailed prepaid or hand-carried. Shipping and handling charges will be applied for all orders that must be mailed when service is complete.

For faster service, RMA authorizations may be requested online (<http://www.supermicro.com/support/rma/>).

Whenever possible, repack the chassis in the original Supermicro carton, using the original packaging material. If these are no longer available, be sure to pack the chassis securely, using packaging material to surround the chassis so that it does not shift within the carton and become damaged during shipping.

This warranty only covers normal consumer use and does not cover damages incurred in shipping or from failure due to the alteration, misuse, abuse or improper maintenance of products.

During the warranty period, contact your distributor first for any product problems.

## Chapter 2

# Standardized Warning Statements for AC Systems

## 2-1 About Standardized Warning Statements

The following statements are industry standard warnings, provided to warn the user of situations which have the potential for bodily injury. Should you have questions or experience difficulty, contact Supermicro's Technical Support department for assistance. Only certified technicians should attempt to install or configure components.

Read this appendix in its entirety before installing or configuring components in the Supermicro chassis.

These warnings may also be found on our web site at [http://www.supermicro.com/about/policies/safety\\_information.cfm](http://www.supermicro.com/about/policies/safety_information.cfm).

### Warning Definition



#### Warning!

This warning symbol means danger. You are in a situation that could cause bodily injury. Before you work on any equipment, be aware of the hazards involved with electrical circuitry and be familiar with standard practices for preventing accidents.

#### 警告の定義

この警告サインは危険を意味します。

人身事故につながる可能性がありますので、いずれの機器でも動作させる前に、電気回路に含まれる危険性に注意して、標準的な事故防止策に精通して下さい。

此警告符号代表危險。

您正处于可能受到严重伤害的工作环境中。在您使用设备开始工作之前，必须充分意识到触电的危险，并熟练掌握防止事故发生的标准工作程序。请根据每项警告结尾的声明号码找到此设备的安全性警告说明的翻译文本。

此警告符號代表危險。

您正處於可能身體可能會受損傷的工作環境中。在您使用任何設備之前，請注意觸電的危險，並且要熟悉預防事故發生的標準工作程序。請依照每一注意事項後的號碼找到相關的翻譯說明內容。

## Warnung

### WICHTIGE SICHERHEITSHINWEISE

Dieses Warnsymbol bedeutet Gefahr. Sie befinden sich in einer Situation, die zu Verletzungen führen kann. Machen Sie sich vor der Arbeit mit Geräten mit den Gefahren elektrischer Schaltungen und den üblichen Verfahren zur Vorbeugung vor Unfällen vertraut. Suchen Sie mit der am Ende jeder Warnung angegebenen Anweisungsnummer nach der jeweiligen Übersetzung in den übersetzten Sicherheitshinweisen, die zusammen mit diesem Gerät ausgeliefert wurden.

BEWAHREN SIE DIESE HINWEISE GUT AUF.

### INSTRUCCIONES IMPORTANTES DE SEGURIDAD

Este símbolo de aviso indica peligro. Existe riesgo para su integridad física. Antes de manipular cualquier equipo, considere los riesgos de la corriente eléctrica y familiarícese con los procedimientos estándar de prevención de accidentes. Al final de cada advertencia encontrará el número que le ayudará a encontrar el texto traducido en el apartado de traducciones que acompaña a este dispositivo.

GUARDE ESTAS INSTRUCCIONES.

### IMPORTANTES INFORMATIONS DE SÉCURITÉ

Ce symbole d'avertissement indique un danger. Vous vous trouvez dans une situation pouvant entraîner des blessures ou des dommages corporels. Avant de travailler sur un équipement, soyez conscient des dangers liés aux circuits électriques et familiarisez-vous avec les procédures couramment utilisées pour éviter les accidents. Pour prendre connaissance des traductions des avertissements figurant dans les consignes de sécurité traduites qui accompagnent cet appareil, référez-vous au numéro de l'instruction situé à la fin de chaque avertissement.

CONSERVEZ CES INFORMATIONS.

## **תקנת הצהרות אזהרה**

הצהרות הבאות הן אזהרות על פי תקני התעשייה, על מנת להזהיר את המשתמש מפני חבלה פיזית אפשרית. במידה ויש שאלות או היתקלות בבעיה כלשהי, יש ליצור קשר עם מחלקת תמיכה טכנית של סופרמיקרו. טכנאים מוסמכים בלבד רשאים להתקין או להגדיר את הרכיבים.

יש לקרוא את הנספח במלוואו לפני התקנת או הגדרת הרכיבים במארוזי סופרמיקרו.

تحذير! هذا الرمز يعني خطر انك في حالة يمكن أن تتسبب في اصابة جسدية .  
قبل أن تعمل على أي معدات، كن على علم بالمخاطر الناجمة عن الدوائر  
الكهربائية  
وكن على دراية بالممارسات الوقائية لمنع وقوع أي حوادث  
استخدم رقم البيان المنصوص في نهاية كل تحذير للعثور ترجمتها

안전을 위한 주의사항

경고!

이 경고 기호는 위험이 있음을 알려 줍니다. 작업자의 신체에 부상을 야기 할 수 있는 상태에 있게 됩니다. 모든 장비에 대한 작업을 수행하기 전에 전기회로와 관련된 위험요소들을 확인하시고 사전에 사고를 방지할 수 있도록 표준 작업절차를 준수해 주시기 바랍니다.

해당 번역문을 찾기 위해 각 경고의 마지막 부분에 제공된 경고문 번호를 참조하십시오

#### BELANGRIJKE VEILIGHEIDSINSTRUCTIES

Dit waarschuwings symbool betekent gevaar. U verkeert in een situatie die lichamelijk letsel kan veroorzaken. Voordat u aan enige apparatuur gaat werken, dient u zich bewust te zijn van de bij een elektrische installatie betrokken risico's en dient u op de hoogte te zijn van de standaard procedures om ongelukken te voorkomen. Gebruik de nummers aan het eind van elke waarschuwing om deze te herleiden naar de desbetreffende locatie.

BEWAAR DEZE INSTRUCTIES

## Installation Instructions



### Warning!

Read the installation instructions before connecting the system to the power source.

設置手順書

システムを電源に接続する前に、設置手順書をお読み下さい。

警告

将此系统连接电源前，请先阅读安装说明。

警告

將系統與電源連接前，請先閱讀安裝說明。

Warnung

Vor dem Anschließen des Systems an die Stromquelle die Installationsanweisungen lesen.

¡Advertencia!

Lea las instrucciones de instalación antes de conectar el sistema a la red de alimentación.

Attention

Avant de brancher le système sur la source d'alimentation, consulter les directives d'installation.

יש לקרוא את הוראות התקנה לפני חיבור המערכת למקור מתח.

اقرأ إرشادات التركيب قبل توصيل النظام إلى مصدر للطاقة

시스템을 전원에 연결하기 전에 설치 안내를 읽어주십시오.

Waarschuwing

Raadpleeg de installatie-instructies voordat u het systeem op de voedingsbron aansluit.



## Circuit Breaker



### Warning!

This product relies on the building's installation for short-circuit (overcurrent) protection. Ensure that the protective device is rated not greater than: 250 V, 20 A.

サーキット・ブレーカー

この製品は、短絡(過電流)保護装置がある建物での設置を前提としています。

保護装置の定格が250 V、20 Aを超えないことを確認下さい。

### 警告

此产品的短路(过载电流)保护由建筑物的供电系统提供,确保短路保护设备的额定电流不大于250V,20A。

### 警告

此产品的短路(过载电流)保护由建筑物的供电系统提供,确保短路保护设备的额定电流不大于250V,20A。

### Warnung

Dieses Produkt ist darauf angewiesen, dass im Gebäude ein Kurzschluss- bzw. Überstromschutz installiert ist. Stellen Sie sicher, dass der Nennwert der Schutzvorrichtung nicht mehr als: 250 V, 20 A beträgt.

### ¡Advertencia!

Este equipo utiliza el sistema de protección contra cortocircuitos (o sobrecorrientes) del edificio. Asegúrese de que el dispositivo de protección no sea superior a: 250 V, 20 A.

### Attention

Pour ce qui est de la protection contre les courts-circuits (surtension), ce produit dépend de l'installation électrique du local. Vérifiez que le courant nominal du dispositif de protection n'est pas supérieur à :250 V, 20 A.

מוצר זה מסתמך על הגנה המותקנת במבנים למניעת קצר חשמלי. יש לוודא כי המכשיר המגן מפני הקצר החשמלי הוא לא יותר מ-250 V, 20 A

هذا المنتج يعتمد على معدات الحماية من الدوائر القصيرة التي تم تثبيتها في المبنى

تأكد من أن تقييم الجهاز الوقائي ليس أكثر من: 20A, 250V

경고!

이 제품은 전원의 단락(과전류)방지에 대해서 전적으로 건물의 관련 설비에 의존합니다. 보호장치의 정격이 반드시 250V(볼트), 20A(암페어)를 초과하지 않도록 해야 합니다.

Waarschuwing

Dit product is afhankelijk van de kortsluitbeveiliging (overspanning) van uw elektrische installatie. Controleer of het beveiligde apparaat niet groter gedimensioneerd is dan 220V, 20A.

## Power Disconnection Warning



### Warning!

The system must be disconnected from all sources of power and the power cord removed from the power supply module(s) before accessing the chassis interior to install or remove system components.

### 電源切斷の警告

システムコンポーネントの取り付けまたは取り外しのために、シャーシ内部にアクセスするには、

システムの電源はすべてのソースから切斷され、電源コードは電源モジュールから取り外す必要があります。

### 警告

在你打开机箱并安装或移除内部器件前，必须将系统完全断电，并移除电源线。

### 警告

在您打開機殼安裝或移除內部元件前，必須將系統完全斷電，並移除電源線。

### Warnung

Das System muss von allen Quellen der Energie und vom Netzanschlusskabel getrennt sein, das von den Spg.Versorgungsteilmodulen entfernt wird, bevor es auf den Chassisinnenraum zurückgreift, um Systemsbestandteile anzubringen oder zu entfernen.

¡Advertencia!

El sistema debe ser disconnected de todas las fuentes de energía y del cable eléctrico quitado de los módulos de fuente de alimentación antes de tener acceso el interior del chasis para instalar o para quitar componentes de sistema.

Attention

Le système doit être débranché de toutes les sources de puissance ainsi que de son cordon d'alimentation secteur avant d'accéder à l'intérieur du châssis pour installer ou enlever des composants de système.

**אזהרה!**

יש לנתק את המערכת מכל מקורות החשמל ויש להסיר את כבל החשמלי מהספק לפני גישה לחלק הפנימי של המארז לצורך התקנת או הסרת רכיבים.

يجب فصل النظام من جميع مصادر الطاقة وإزالة سلك الكهرباء من وحدة امداد الطاقة قبل الوصول إلى المناطق الداخلية للهيكल لتثبيت أو إزالة مكونات الجهاز

경고!

시스템에 부품들을 장착하거나 제거하기 위해서는 새시 내부에 접근하기 전에 반드시 전원 공급장치로부터 연결되어있는 모든 전원과 전기코드를 분리해주어야 합니다.

Waarschuwing

Voordat u toegang neemt tot het binnenwerk van de behuizing voor het installeren of verwijderen van systeem onderdelen, dient u alle spanningsbronnen en alle stroomkabels aangesloten op de voeding(en) van de behuizing te verwijderen

## Equipment Installation



### Warning!

Only trained and qualified personnel should be allowed to install, replace, or service this equipment.

### 機器の設置

トレーニングを受け認定された人だけがこの装置の設置、交換、またはサービスを許可されています。

### 警告

只有经过培训且具有资格的人员才能进行此设备的安装、更换和维修。

### 警告

只有經過受訓且具資格人員才可安裝、更換與維修此設備。

### Warnung

Das Installieren, Ersetzen oder Bedienen dieser Ausrüstung sollte nur geschultem, qualifiziertem Personal gestattet werden.

### ¡Advertencia!

Solamente el personal calificado debe instalar, reemplazar o utilizar este equipo.

### Attention

Il est vivement recommandé de confier l'installation, le remplacement et la maintenance de ces équipements à des personnels qualifiés et expérimentés.

### אזהרה!

צוות מוסמך בלבד רשאי להתקין, להחליף את הציוד או לתת שירות עבור הציוד.

يجب أن يسمح فقط للموظفين المؤهلين والمدربين لتثبيت واستبدال أو خدمة هذا الجهاز

### 경고!

훈련을 받고 공인된 기술자만이 이 장비의 설치, 교체 또는 서비스를 수행할 수 있습니다.

## Waarschuwing

Deze apparatuur mag alleen worden geïnstalleerd, vervangen of hersteld door geschoold en gekwalificeerd personeel.

## Restricted Area



### Warning!

This unit is intended for installation in restricted access areas. A restricted access area can be accessed only through the use of a special tool, lock and key, or other means of security. (This warning does not apply to workstations).

## アクセス制限区域

このユニットは、アクセス制限区域に設置されることを想定しています。

アクセス制限区域は、特別なツール、鍵と錠前、その他のセキュリティの手段を用いてのみ出入りが可能です。

## 警告

此部件应安装在限制进出的场所，限制进出的场所指只能通过使用特殊工具、锁和钥匙或其它安全手段进出的场所。

## 警告

此裝置僅限安裝於進出管制區域，進出管制區域係指僅能以特殊工具、鎖頭及鑰匙或其他安全方式才能進入的區域。

## Warnung

Diese Einheit ist zur Installation in Bereichen mit beschränktem Zutritt vorgesehen. Der Zutritt zu derartigen Bereichen ist nur mit einem Spezialwerkzeug, Schloss und Schlüssel oder einer sonstigen Sicherheitsvorkehrung möglich.

## ¡Advertencia!

Esta unidad ha sido diseñada para instalación en áreas de acceso restringido. Sólo puede obtenerse acceso a una de estas áreas mediante la utilización de una herramienta especial, cerradura con llave u otro medio de seguridad.

## Attention

Cet appareil doit être installée dans des zones d'accès réservés. L'accès à une zone d'accès réservé n'est possible qu'en utilisant un outil spécial, un mécanisme de verrouillage et une clé, ou tout autre moyen de sécurité.

## אזור עם גישה מוגבלת

### אזהרה!

יש להתקין את היחידה באזורים שיש בהם הגבלת גישה. הגישה ניתנת בעזרת כלי אבטחה בלבד (מפתח, מנעול וכד').

تم تخصيص هذه الوحدة لت تركيبها في مناطق محظورة . يمكن الوصول إلى منطقة محظورة فقط من خلال استخدام أداة خاصة، قفل ومفتاح أو أي وسيلة أخرى للالأمان

경고!

이 장치는 접근이 제한된 구역에 설치하도록 되어있습니다. 특수도구, 잠금 장치 및 키, 또는 기타 보안 수단을 통해서만 접근 제한 구역에 들어갈 수 있습니다.

Waarschuwing

Dit apparaat is bedoeld voor installatie in gebieden met een beperkte toegang. Toegang tot dergelijke gebieden kunnen alleen verkregen worden door gebruik te maken van speciaal gereedschap, slot en sleutel of andere veiligheidsmaatregelen.

## Battery Handling



### Warning!

There is the danger of explosion if the battery is replaced incorrectly. Replace the battery only with the same or equivalent type recommended by the manufacturer. Dispose of used batteries according to the manufacturer's instructions

電池の取り扱い

電池交換が正しく行われなかった場合、破裂の危険性があります。交換する電池はメーカーが推奨する型、または同等のものを使用下さい。使用済電池は製造元の指示に従って処分して下さい。

警告

電池更換不當會有爆炸危險。請只使用同類電池或製造商推薦的功能相當的電池更換原有電池。請按製造商的說明處理廢舊電池。

警告

電池更換不當會有爆炸危險。請使用製造商建議之相同或功能相當的電池更換原有電池。請按照製造商的說明指示處理廢棄舊電池。

Warnung

Bei Einsetzen einer falschen Batterie besteht Explosionsgefahr. Ersetzen Sie die Batterie nur durch den gleichen oder vom Hersteller empfohlenen Batterietyp. Entsorgen Sie die benutzten Batterien nach den Anweisungen des Herstellers.

Attention

Danger d'explosion si la pile n'est pas remplacée correctement. Ne la remplacer que par une pile de type semblable ou équivalent, recommandée par le fabricant. Jeter les piles usagées conformément aux instructions du fabricant.

¡Advertencia!

Existe peligro de explosión si la batería se reemplaza de manera incorrecta. Reemplazar la batería exclusivamente con el mismo tipo o el equivalente recomendado por el fabricante. Desechar las baterías gastadas según las instrucciones del fabricante.

**אזהרה!**

קיימת סכנת פיצוץ של הסוללה במידה והוחלפה בדרך לא תקינה. יש להחליף את הסוללה בסוג התואם מחברת יצרן מומלצת.

סילוק הסוללות המשומשות יש לבצע לפי הוראות היצרן.

هناك خطر من انفجار في حالة استبدال البطارية بطريقة غير صحيحة فعليك استبدال البطارية فقط بنفس النوع أو ما يعادلها كما أوصت به الشركة المصنعة تخلص من البطاريات المستعملة وفقا لتعليمات الشركة الصانعة

경고!

배터리가 올바르게 교체되지 않으면 폭발의 위험이 있습니다. 기존 배터리와 동일하거나 제조사에서 권장하는 동등한 종류의 배터리로만 교체해야 합니다. 제조사의 안내에 따라 사용된 배터리를 처리하여 주십시오.

Waarschuwing

Er is ontploffingsgevaar indien de batterij verkeerd vervangen wordt. Vervang de batterij slechts met hetzelfde of een equivalent type die door de fabrikant aanbevolen wordt. Gebruikte batterijen dienen overeenkomstig fabrieksvoorschriften afgevoerd te worden.

## Redundant Power Supplies



### Warning!

This unit might have more than one power supply connection. All connections must be removed to de-energize the unit.

#### 冗長電源装置

このユニットは複数の電源装置が接続されている場合があります。  
ユニットの電源を切るためには、すべての接続を取り外さなければなりません。

#### 警告

此部件连接的电源可能不止一个，必须将所有电源断开才能停止给该部件供电。

#### 警告

此装置连接的電源可能不只一個，必須切斷所有電源才能停止對該裝置的供電。

#### Warnung

Dieses Gerät kann mehr als eine Stromzufuhr haben. Um sicherzustellen, dass der Einheit kein Strom zugeführt wird, müssen alle Verbindungen entfernt werden.

#### ¡Advertencia!

Puede que esta unidad tenga más de una conexión para fuentes de alimentación. Para cortar por completo el suministro de energía, deben desconectarse todas las conexiones.

#### Attention

Cette unité peut avoir plus d'une connexion d'alimentation. Pour supprimer toute tension et tout courant électrique de l'unité, toutes les connexions d'alimentation doivent être débranchées.

**אם קיים יותר מספק אחד**

**אזהרה!**

ליחידה יש יותר מחיבור אחד של ספק. יש להסיר את כל החיבורים על מנת לרוקן את היחידה.



قد يكون لهذا الجهاز عدة اتصالات بوحدات امداد الطاقة.  
يجب إزالة كافة الاتصالات لعزل الوحدة عن الكهرباء

경고!

이 장치에는 한 개 이상의 전원 공급 단자가 연결되어 있을 수 있습니다. 이 장치에 전원을 차단하기 위해서는 모든 연결 단자를 제거해야만 합니다.

Waarschuwing

Deze eenheid kan meer dan één stroomtoevoeraansluiting bevatten. Alle aansluitingen dienen verwijderd te worden om het apparaat stroomloos te maken.

### Backplane Voltage



**Warning!**

Hazardous voltage or energy is present on the backplane when the system is operating. Use caution when servicing.

バックプレーンの電圧

システムの稼働中は危険な電圧または電力が、バックプレーン上にかかっています。

修理する際にはご注意ください。

警告

当系統正在进行时，背板上有很危险的电压或能量，进行维修时务必小心。

警告

當系統正在進行時，背板上有很危險的電壓或能量，進行維修時務必小心。

Warnung

Wenn das System in Betrieb ist, treten auf der Rückwandplatine gefährliche Spannungen oder Energien auf. Vorsicht bei der Wartung.

¡Advertencia!

Cuando el sistema está en funcionamiento, el voltaje del plano trasero es peligroso. Tenga cuidado cuando lo revise.

Attention

Lorsque le système est en fonctionnement, des tensions électriques circulent sur le fond de panier. Prendre des précautions lors de la maintenance.

## מתח בפנל האחורי

אזהרה!  
קיימת סכנת מתח בפנל האחורי בזמן תפעול המערכת. יש להיזהר במהלך  
העבודה.

هناك خطر من التيار الكهربائي أو الطاقة الموجودة على اللوحة  
عندما يكون النظام يعمل كن حذرا عند خدمة هذا الجهاز

경고!

시스템이 동작 중일 때 후면판 (Backplane)에는 위험한 전압이나 에너지가 발생  
합니다. 서비스 작업 시 주의하십시오.

Waarschuwing

Een gevaarlijke spanning of energie is aanwezig op de backplane wanneer het  
systeem in gebruik is. Voorzichtigheid is geboden tijdens het onderhoud.

## Comply with Local and National Electrical Codes



### Warning!

Installation of the equipment must comply with local and national electrical codes.

地方および国の電気規格に準拠

機器の取り付けはその地方および国の電気規格に準拠する必要があります。

警告

设备安装必须符合本地与本国电气法规。

警告

設備安裝必須符合本地與本國電氣法規。

Warnung

Die Installation der Geräte muss den Sicherheitsstandards entsprechen.

¡Advertencia!

La instalación del equipo debe cumplir con las normas de electricidad locales y  
nacionales.

Attention

L'équipement doit être installé conformément aux normes électriques nationales et locales.

**תיאום חוקי החשמל הארצי**

**אזהרה!**

התקנת הציוד חייבת להיות תואמת לחוקי החשמל המקומיים והארציים.

تركيب المعدات الكهربائية يجب أن يمتثل للقوانين المحلية والوطنية المتعلقة بالكهرباء

경고!

현 지역 및 국가의 전기 규정에 따라 장비를 설치해야 합니다.

Waarschuwing

Bij installatie van de apparatuur moet worden voldaan aan de lokale en nationale elektriciteitsvoorschriften.

**Product Disposal**



**Warning!**

Ultimate disposal of this product should be handled according to all national laws and regulations.

**製品の廃棄**

この製品を廃棄処分する場合、国の関係する全ての法律・条例に従い処理する必要があります。

**警告**

本产品的废弃处理应根据所有国家的法律和规章进行。

**警告**

本產品的廢棄處理應根據所有國家的法律和規章進行。

**Warnung**

Die Entsorgung dieses Produkts sollte gemäß allen Bestimmungen und Gesetzen des Landes erfolgen.

¡Advertencia!

Al deshacerse por completo de este producto debe seguir todas las leyes y reglamentos nacionales.

Attention

La mise au rebut ou le recyclage de ce produit sont généralement soumis à des lois et/ou directives de respect de l'environnement. Renseignez-vous auprès de l'organisme compétent.

## סילוק המוצר

אזהרה!

סילוק סופי של מוצר זה חייב להיות בהתאם להנחיות וחוקי המדינה.

عند التخلص النهائي من هذا المنتج ينبغي التعامل معه وفقا لجميع القوانين واللوائح الوطنية

경고!

이 제품은 해당 국가의 관련 법규 및 규정에 따라 폐기되어야 합니다.

Waarschuwing

De uiteindelijke verwijdering van dit product dient te geschieden in overeenstemming met alle nationale wetten en reglementen.

## Hot Swap Fan Warning



### Warning!

The fans might still be turning when you remove the fan assembly from the chassis. Keep fingers, screwdrivers, and other objects away from the openings in the fan assembly's housing.

ファン・ホットスワップの警告

シャーシから冷却ファン装置を取り外した際、ファンがまだ回転している可能性があります。ファンの開口部に、指、ドライバー、およびその他のものを近づけないで下さい。

警告

当您从机架移除风扇装置，风扇可能仍在转动。小心不要将手指、螺丝起子和其他物品太靠近风扇

**警告**

當您從機架移除風扇裝置，風扇可能仍在轉動。小心不要將手指、螺絲起子和其他物品太靠近風扇。

**Warnung**

Die Lüfter drehen sich u. U. noch, wenn die Lüfterbaugruppe aus dem Chassis genommen wird. Halten Sie Finger, Schraubendreher und andere Gegenstände von den Öffnungen des Lüftergehäuses entfernt.

**¡Advertencia!**

Los ventiladores podran dar vuelta cuando usted quite el montaje del ventilador del chasis. Mantenga los dedos, los destornilladores y todos los objetos lejos de las aberturas del ventilador

**Attention**

Il est possible que les ventilateurs soient toujours en rotation lorsque vous retirez le bloc ventilateur du châssis. Prenez garde à ce que doigts, tournevis et autres objets soient éloignés du logement du bloc ventilateur.

**אזהרה!**

כאשר מסירים את חלקי המאוורר מהמארז, יתכן והמאווררים עדיין עובדים. יש להרחיק למרחק בטוח את האצבעות וכלי עבודה שונים מהפתחים בתוך המאוורר

من الممكن أن المراوح لا تزال تدور عند إزالة كتلة المروحة من الهيكل يجب إبقاء الأصابع ومفكات البراغي وغيرها من الأشياء بعيدا عن الفتحات في كتلة المروحة.

**경고!**

새시로부터 팬 조립품을 제거할 때 팬은 여전히 회전하고 있을 수 있습니다. 팬 조립품 외관의 열려있는 부분들로부터 손가락 및 스크류드라이버, 다른 물체들이 가까이 하지 않도록 배치해 주십시오.

**Waarschuwing**

Het is mogelijk dat de ventilator nog draait tijdens het verwijderen van het ventilatorsamenstel uit het chassis. Houd uw vingers, schroevendraaiers en eventuele andere voorwerpen uit de buurt van de openingen in de ventilatorbehuizing.

## Power Cable and AC Adapter



### Warning!

When installing the product, use the provided or designated connection cables, power cables and AC adaptors. Using any other cables and adaptors could cause a malfunction or a fire. Electrical Appliance and Material Safety Law prohibits the use of UL or CSA -certified cables (that have UL/CSA shown on the code) for any other electrical devices than products designated by Supermicro only.

### 電源コードとACアダプター

製品を設置する場合、提供または指定された接続ケーブル、電源コードとACアダプターを使用下さい。他のケーブルやアダプタを使用すると故障や火災の原因になることがあります。電気用品安全法は、ULまたはCSA認定のケーブル(UL/CSEマークがコードに表記)をSupermicroが指定する製品以外に使用することを禁止しています。

### 警告

安装此产品时,请使用本身提供的或指定的连接线,电源线和电源适配器.使用其它线材或适配器可能会引起故障或火灾.除了Supermicro所指定的产品,电气用品和材料安全法律规定禁止使用未经UL或CSA认证的线材。(线材上会显示UL/CSA符号)。

### 警告

安装此產品時,請使用本身提供的或指定的連接線,電源線和電源適配器.使用其它線材或適配器可能會引起故障或火災.除了Supermicro所指定的產品,電氣用品和材料安全法律規定禁止使用未經UL或CSA認證的線材。(線材上會顯示UL/CSA符號)。

### Warnung

Bei der Installation des Produkts, die zur Verfügung gestellten oder benannt Anschlusskabel, Stromkabel und Netzteile. Verwendung anderer Kabel und Adapter kann zu einer Fehlfunktion oder ein Brand entstehen. Elektrische Geräte und Material Safety Law verbietet die Verwendung von UL-oder CSA-zertifizierte Kabel, UL oder CSA auf der Code für alle anderen elektrischen Geräte als Produkte von Supermicro nur bezeichnet gezeigt haben.

### ¡Advertencia!

Al instalar el producto, utilice los cables de conexión previstos o designados, los cables y adaptadores de CA. La utilización de otros cables y adaptadores podría ocasionar un mal funcionamiento o un incendio. Aparatos Eléctricos y la Ley de Seguridad del Material prohíbe el uso de UL o CSA cables certificados que tienen UL o CSA se muestra en el código de otros dispositivos eléctricos que los productos designados por Supermicro solamente.

**Attention**

Lors de l'installation du produit, utilisez les bables de connection fournis ou désigné. L'utilisation d'autres cables et adaptateurs peut provoquer un dysfonctionnement ou un incendie. Appareils électroménagers et de loi sur la sécurité Matériel interdit l'utilisation de UL ou CSA cables certifiés qui ont UL ou CSA indiqué sur le code pour tous les autres appareils électriques que les produits désignés par Supermicro seulement.

**חשמליים ומתאמי AC****אזהרה!**

כאשר מתקינים את המוצר, יש להשתמש בכבלים, ספקים ומתאמים AC אשר נועדו וסופקו לשם כך. שימוש בכל כבל או מתאם אחר יכול לגרום לתקלה או קצר חשמלי. על פי חוקי שימוש במכשירי חשמל וחוקי בטיחות, קיים איסור להשתמש בכבלים המוסמכים ב- UL או ב- CSA (כשאר מופיע עליהם קוד של UL/CSA) עבור כל מוצר חשמלי אחר שלא צויין על ידי סופרמיקרו בלבד.

عند تركيب الجهاز يجب استخدام كابلات التوصيل، والكابلات الكهربائية ومحولات التيار المتردد التي . أن استخدام أي كابلات ومحولات أخرى يتسبب في حدوث عطل أو حريق. تم توفيرها لك مع المنتج الأجهزة الكهربائية ومواد قانون السلامة يحظر استخدام الكابلات UL أو CSA معتمدة من قبل لأي أجهزة كهربائية أخرى غير المنتجات المعينة من قبل Supermicro (التي تحمل علامة UL/CSA)

**경고!**

제품을 설치할 때에는 제공되거나 지정된 연결케이블과 전원케이블, AC 어댑터를 사용해야 합니다. 그 밖의 다른 케이블들이나 어댑터들은 고장 또는 화재의 원인이 될 수 있습니다. 전기용품안전법 (Electrical Appliance and Material Safety Law)은 슈퍼마이크로에서 지정한 제품들 외에는 그 밖의 다른 전기 장치들을 위한 UL 또는 CSA에서 인증한 케이블(전선 위에 UL/CSA가 표시)들의 사용을 금지합니다.

**Waarschuwing**

Bij het installeren van het product, gebruik de meegeleverde of aangewezen kabels, stroomkabels en adapters. Het gebruik van andere kabels en adapters kan leiden tot een storing of een brand. Elektrisch apparaat en veiligheidsinformatiebladen wet verbiedt het gebruik van UL of CSA gecertificeerde kabels die UL of CSA die op de code voor andere elektrische apparaten dan de producten die door Supermicro alleen.

## Notes



## Chapter 3

# Chassis Components

### 3-1 Overview

This chapter describes the most common components included with your chassis. Some components listed may not be included or compatible with your particular chassis model. For more information, see the installation instructions detailed later in this manual.

### 3-2 Components

The SC819 chassis includes four 3.5" hard drive bays, and may include one slim DVD-ROM (optional). For the latest shipping lists, visit our web site at: <http://www.supermicro.com>.

#### Backplane

Each SC819 chassis comes with a 1U backplane. The backplane will accept SAS/SATA hard drives. For more information regarding compatible backplanes, view the appendices found at the end of this manual. In addition, visit our Web site for the latest information: <http://www.supermicro.com>.

#### Fans

The SC819 chassis accepts five system fans with an optional sixth fan. System fans for the SC819 chassis are powered from the motherboard. These fans are 1U high and are powered by 4-pin connectors.

#### Mounting Rails

The SC819 can be placed in a rack for secure storage and use. To set up your rack, follow the step-by-step instructions included in this manual.

#### Power Supply

Each SC819 chassis model includes a high-efficiency, hot-swappable power supply rated at 700 Watts. In the unlikely event that your power supply fails, replacement is simple and can be done without tools.

### **Air Shroud (Optional)**

The SC819 chassis supports an optional air shroud. An air shroud is a shield, usually made of plastic, which funnels air directly to where cooling is needed.

## **3-3 Where to get Replacement Components**

Although not frequently, you may need replacement parts for your system. To ensure the highest level of professional service and technical support, we strongly recommend purchasing exclusively from our Supermicro Authorized Distributors/System Integrators/Resellers. A list of Supermicro Authorized Distributors/System Integrators/Reseller can be found at: <http://www.supermicro.com>. Click the Where to Buy link.

# Chapter 4

## System Interface

### 4-1 Overview

There are several LEDs on the control panel and on the drive carriers that provide system and component status. This chapter explains the meanings of all LED indicators and the appropriate responses that may need to be taken.

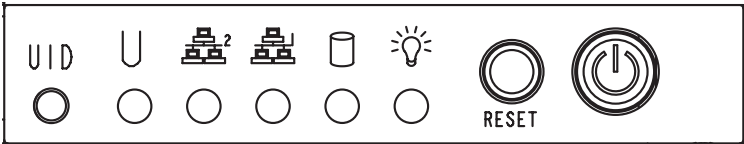
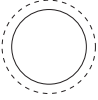

Figure 4-1. Control Panel Buttons and LEDs

## 4-2 Control Panel Buttons

The SC819 chassis includes two or three push-buttons located on the front panel: a reset button, a power on/off button, and a UID button



**Reset:** The reset button is used to reboot the system.



**Power:** The main power switch is used to apply or remove power from the power supply to the server system. Turning off system power with this button removes the main power but keeps standby power supplied to the system. Therefore, you must unplug system before servicing.



**UID:** When used with a UID-compatible motherboard, the UID button is used to turn on or off the blue light function of the the U-LED. Once the blue light is activated, the unit can be easily located in very large racks and server banks.

## 4-3 Control Panel LEDs

The control panel located on the front of the SC819 chassis has up to five LEDs. These LEDs provide critical information related to different parts of the system. This section explains what each LED indicates when illuminated and any action that may be required.



**Universal Information LED:** The Universal Information LED is used to indicate a fan failure, power failure, overheat condition, or to identify the unit within a large rack installation. The feature requires a motherboard that supports the Universal Information LED.

When this LED blinks red quickly, it indicates a fan failure and when blinking red slowly a power failure. This LED will be blue when used for UID (Unit Identifier). When on continuously red, it indicates an overheat condition, which may be caused by cables obstructing the airflow in the system or the ambient room temperature being too warm. See the table below for descriptions of the LED states.

Universal Information LED States	
State	Indication
Fast Blinking Red (1x/sec)	Fan Fail
Solid Red	CPU Overheat
Slow Blinking Red (1x/4 sec)	Power Fail
Solid Blue	Local UID Button Depressed
Blinking Blue	IPMI-Activated UID

**Figure 4-2: Universal Information LED States**

**Note:** Deactivating the UID LED must be performed in the same way it was activated. (If the UID LED was activated via IPMI, you can only turn the LED off via IPMI and not with the UID button.)



NIC2: Indicates network activity on GLAN2 when flashing.



NIC1: Indicates network activity on GLAN1 when flashing.



HDD: Indicates IDE channel activity, SAS/SATA drive and/or DVD-ROM drive activity when flashing.



Power: Indicates power is being supplied to the system's power supply units. This LED should normally be illuminated when the system is operating.

## 4-4 Drive Carrier LEDs

Your chassis uses SAS/SATA drives.

### SAS/SATA Drives

Each SAS/SATA drive carrier has two LEDs.

**Green:** Each Serial ATA drive carrier has a green LED. When illuminated, this green LED (on the front of the SATA drive carrier) indicates drive activity. A connection to the SATA backplane enables this LED to blink on and off when that particular drive is being accessed.

**Red:** The red LED to indicate an SAS/SATA drive failure. If one of the SAS/SATA drives fail, you should be notified by your system management software.

## 4-5 Power Supply LEDs and Overheat Indicators

The SC819 chassis is equipped with LED indicators to keep you informed of the system's status.

- **Solid Green:** When illuminated, this green LED indicates that the power supply is on.
- **Solid Amber:** When illuminated, the amber LED indicates the power supply is plugged in and turned off, or the system is off but in an abnormal state.

All Other Power Supply LEDs	
State	Indication
Solid Green	System is on.
Solid Amber	System is off and plugged in.

## 4-6 Overheating

The section lists actions that should be taken in the unlikely event the server overheats.

### **Overheat Temperature Setting**

Some backplanes allow the overheat temperature to be set at 45, 50, or 55 degrees Fahrenheit by changing a jumper setting. For more backplane information, see the appendix at the back of this manual or download the backplane user manual at [www.supernmicro.com](http://www.supernmicro.com). To access the manuals on the Website, click Support, and then click the Manuals link.

### **Overheating Condition**

*If the server overheats, do the following:*

1. Use the LEDs to determine the nature of the overheating condition.
2. Confirm that the chassis covers are installed properly.
3. Check the routing of the cables and make sure all fans are present and operating normally.
4. Verify that the heatsinks are installed properly.



## Chapter 5

# Chassis Setup and Maintenance

### 5-1 Overview

This chapter covers the steps required to install components and perform maintenance on the chassis. The only tool needed to install components and perform maintenance is a Phillips screwdriver. Print this page to use as a reference while setting up your chassis.

**Review the warnings and precautions listed in the manual before setting up or servicing this chassis. These include information in Chapter 2: System Safety and the warning/precautions listed in the setup instructions.**

## 5-2 Removing the Chassis Cover

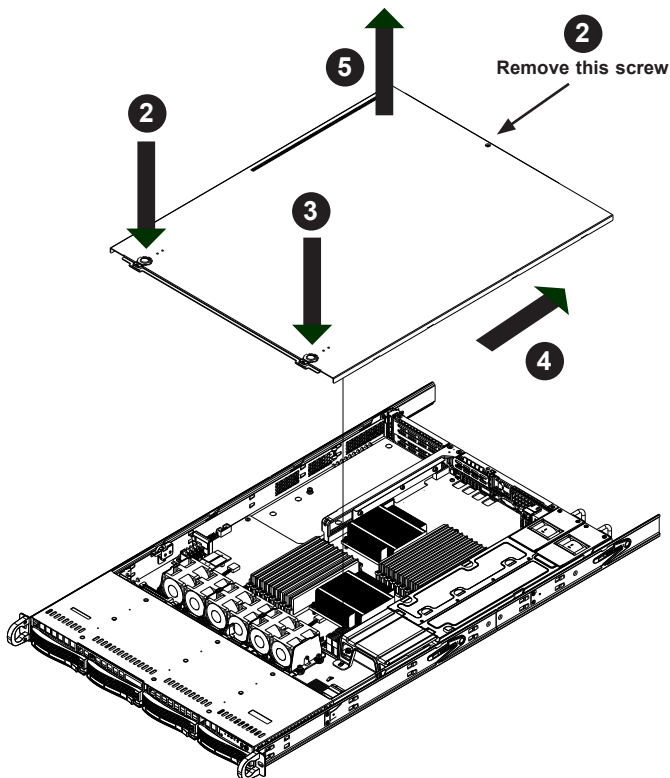

Figure 5-1: Removing the Chassis Cover

### *Removing the Chassis Cover*

1. Power down the system and unplug the power cords from the rear of the power supplies.
2. Remove the screw at the rear of the cover.
3. Press the release tabs simultaneously.
4. Slide the cover back toward the rear of the chassis.
5. Lift the cover up and off of the chassis.

**Warning:** Except for short periods of time, do NOT operate the server without the cover in place. The chassis cover must be in place to allow proper airflow and prevent overheating.

## 5-3 Installing Hard Drives

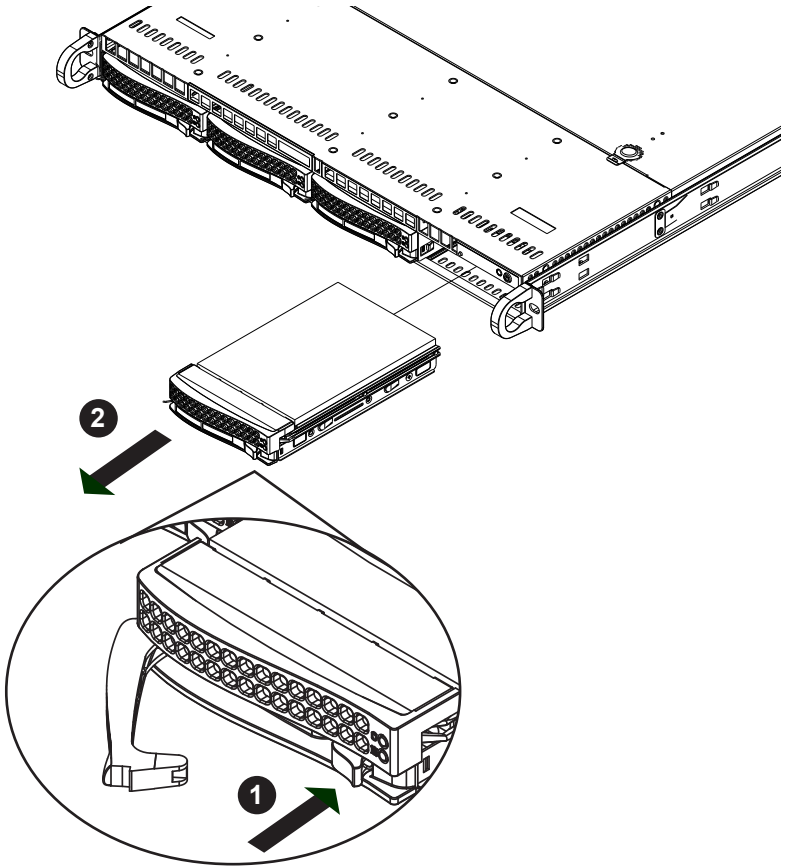
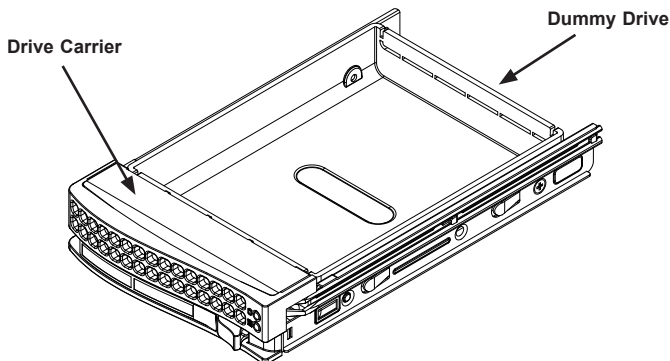

Figure 5-2: Removing Hard Drive Carriers

The SC819 chassis includes hot-swappable hard drives that can be removed from the chassis and reinstalled without powering down the server.

### ***Removing Hard Drive Carriers from the Chassis***

1. Press the release button on the drive carrier, which extends the drive carrier handle.
2. Use the handle to pull the drive carrier out of the chassis.



**Figure 5-3: Chassis Drive Carrier**

The drives are mounted in drive carriers to simplify their installation and removal from the chassis. These carriers also help promote proper airflow for the drive bays.

**Warning:** Except for short periods of time while swapping hard drives, do not operate the chassis without the drive carriers.

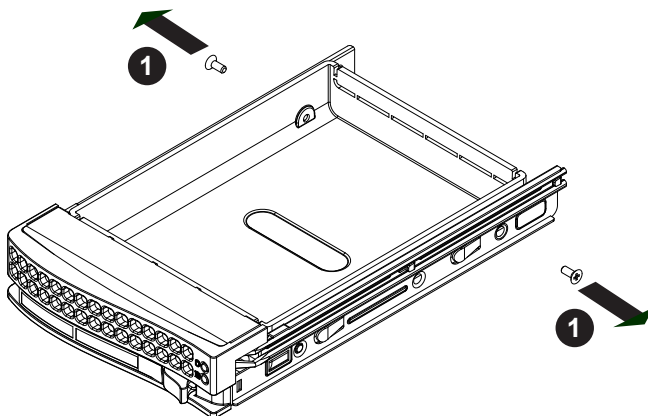

**Figure 5-4: Removing a Dummy Drive from the Carrier**

#### ***Installing a Hard Drive to the Hard Drive Carrier***

1. Remove the two screws securing the dummy drive to the carrier.
2. Remove the dummy drive from the carrier.

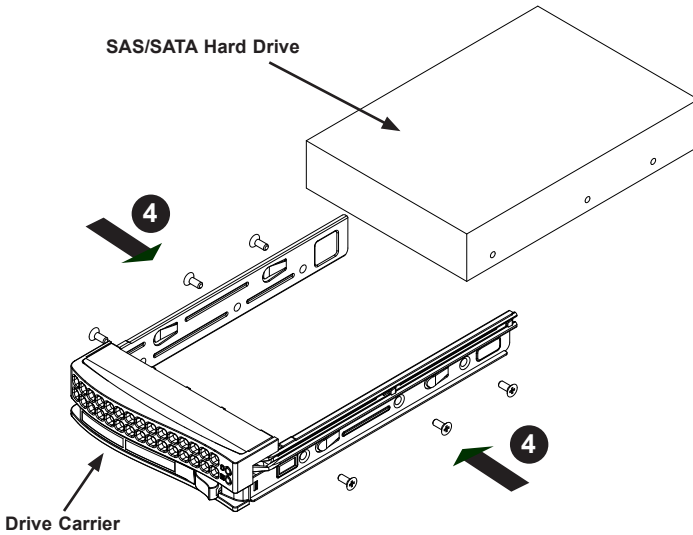

**Figure 5-5: Removing the Hard Drive From the Carrier**

3. Install a new drive into the carrier with the printed circuit board side facing down so that the mounting holes in the drive align with those in the carrier.
4. Secure the hard drive by tightening all six screws.
5. Return the drive carrier to the chassis drive bay. Close the drive carrier handle to lock the drive into the drive bay.

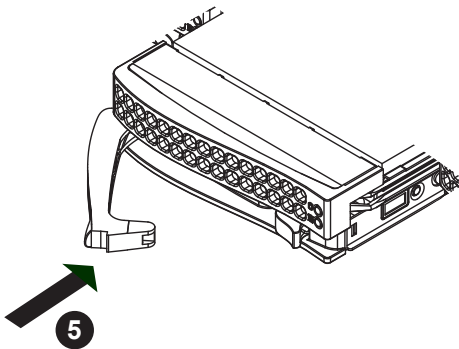

**Figure 5-6: Replacing the Hard Drive Carrier**

## 5-4 DVD and USB COM Tray Installation

SC819 chassis models support an optional DVD-ROM or USB COM tray.

### *Installing or Replacing a DVD-ROM or USB COM Tray*

1. Power down the system, remove the power cords from the rear of the power supplies and remove the chassis cover as described in Section 5-3.
2. If necessary, remove the server from the rack and the front bezel from the chassis.
3. Remove the chassis cover.
4. Unplug the drives power and data cables from the motherboard and/or back-plane.
5. If you are adding a new drive: Remove the mini-bezel (grate) from the drive bay. The bezel can be removed by pulling out the hard drive beneath the DVD-ROM or USB COM tray bay, then pulling the mini-bezel forward.

If you are replacing a drive: Locate the locking tab at the rear (left hand side when viewed from the front) of the DVD-ROM or USB COM tray. Push the tab toward the drive and push the drive unit out the front of the chassis.

6. Insert the new drive unit in the slot until the tab locks in place.
7. Reconnect the data and power cables.
8. Replace the chassis cover (replace the server in the rack, if necessary) and power up the system.

## 5-5 Installing the Motherboard

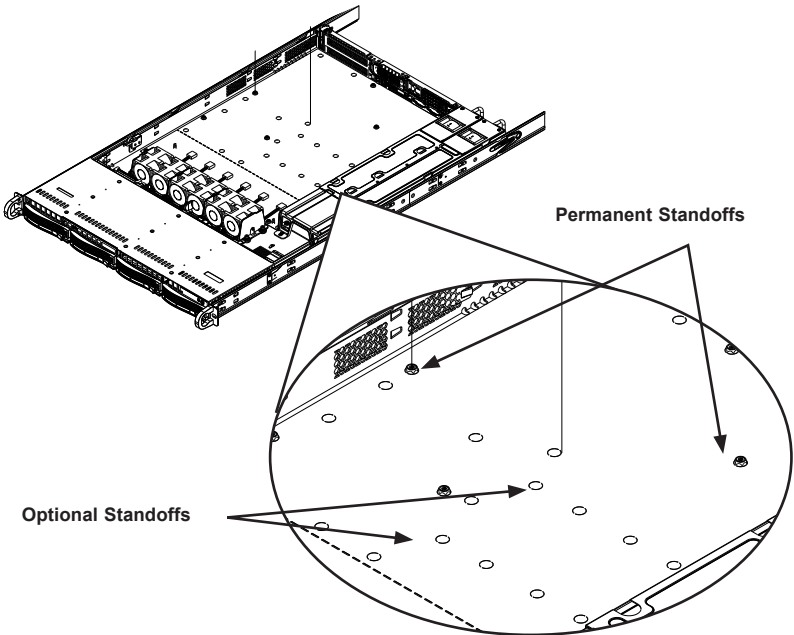
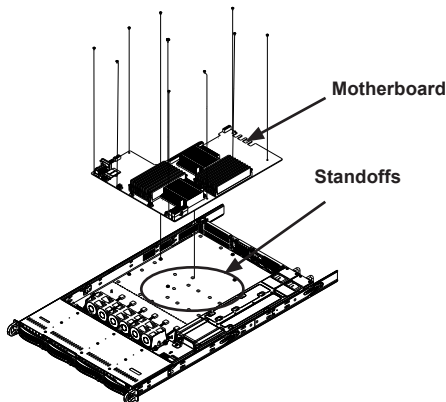

Figure 5-7: Chassis Standoffs

### Permanent and Optional Standoffs

Standoffs prevent short circuits by securing space between the motherboard and the chassis surface. The SC819 chassis includes permanent standoffs in locations used by most motherboards. These standoffs accept the rounded Phillips head screws included in the SC819 accessories packaging.

Some motherboards require additional screws for heatsinks and/or general components. Optional standoffs are included for these motherboards. To use an optional standoff, you must place the hexagonal screw through the bottom the chassis and secure the screw with the hexagonal nut (rounded side up).



**Figure 5-8: Installing the Motherboard**

### ***Installing the Motherboard***

1. Review the documentation that came with your motherboard. Become familiar with component placement, requirements, and precautions.
1. Power down the system, remove the power cords from the rear of the power supplies and remove the chassis cover as described in Section 5-3.
2. Open the chassis cover.
3. If necessary, remove the riser card.
4. As required by your motherboard, install standoffs in any areas that do not have a permanent standoff:
  - A. Compare the mounting holes on the motherboard to the mounting holes in the chassis, then add or move standoffs to match the motherboard mounting hole locations.
  - B. Place a hexagonal standoff screw through the bottom the chassis.
  - C. Secure the screw with the hexagonal nut (rounded side up).
5. Lay the motherboard on the chassis aligning the permanent and optional standoffs
6. Secure the motherboard to the chassis using the rounded, Phillips head screws. Do not exceed eight pounds of torque per square inch, when tightening down the motherboard.
7. Secure the CPU(s), heatsinks, and other components to the motherboard, chassis, and/or backplane as needed.



## Expansion Card Setup

The SC819 chassis features two full-height/full-length PCI slots and one low-profile PCI slot.

Note: You must use a riser card to install expansion cards to any SC819 chassis. Riser cards are sold separately.

For the latest compatibility and performance information visit our website at: <http://www.supermicro.com>.

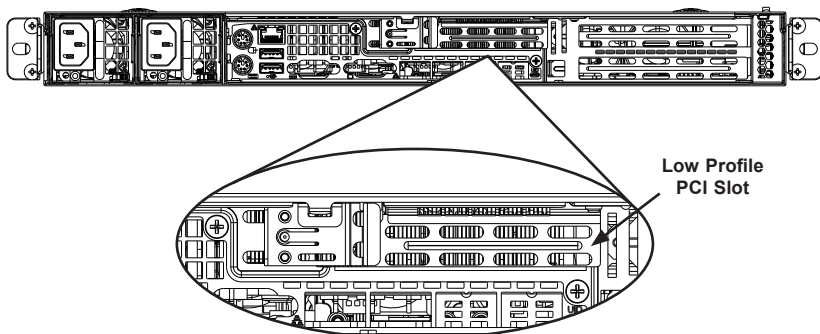

Figure 5-9: One Low-Profile Expansion Slot

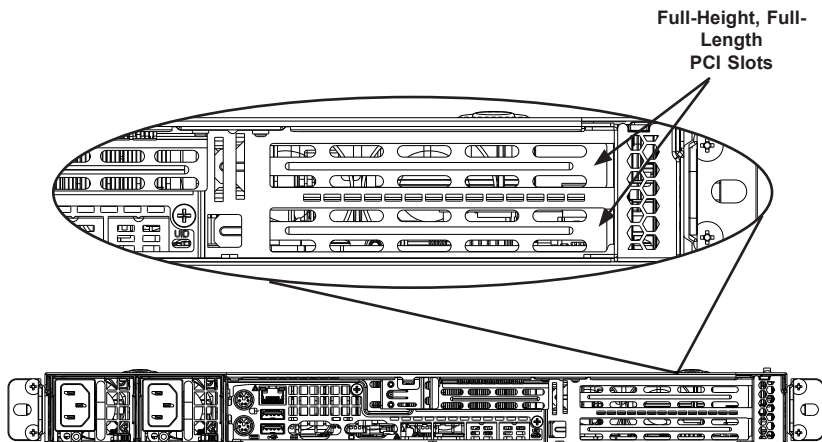

Figure 5-10: SC819 Two Full-Height/Full-Length PCI slots and One Low-Profile PCI slot

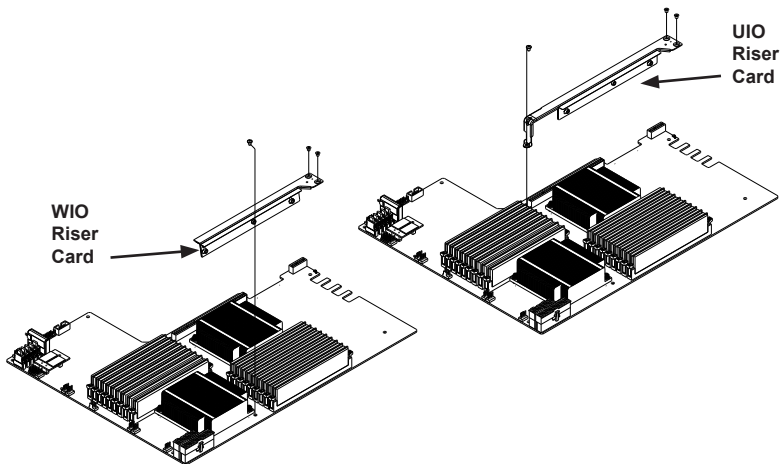

Figure 5-11: Installing a Riser Card

### ***Installing an Expansion Card***

1. Power down the system, remove the power cords from the rear of the power supplies and remove the chassis cover as described in Section 5-3. Confirm that you have the correct riser card for your chassis model and that the expansion card includes a standard PCI slot bracket.
2. Install the expansion card by sliding the riser card into the appropriate slot in the motherboard and secure it using one of the two methods illustrated above. For more information, see the installation instructions included with the riser card.
3. Choose the PCI slot in which to place the expansion card.
4. In that slot, open the PCI slot lever and slide the PCI slot cover sideways.
5. From inside the chassis, remove the PCI slot cover.
6. Insert the expansion card into the riser card and slide the expansion card bracket into the PCI slot bracket.
7. Secure the expansion card in the PCI slot by closing the PCI slot lever.
8. Connect cables to the expansion card as necessary.

## 5-6 Installing the Air Shroud (Optional)

The SC819 chassis supports an optional air shroud. Air shrouds concentrate airflow to maximize fan efficiency. The air shroud does not require screws to set up.

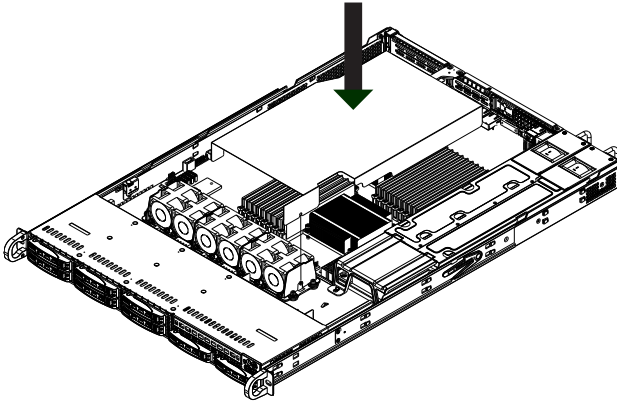

**Figure 5-12: Installing the Air Shroud**

### *Installing the Air Shroud (Optional)*

1. Power down the system, remove the power cords from the rear of the power supplies and remove the chassis cover as described in Section 5-3.
2. If your motherboard uses between nine and sixteen DIMMS, skip this step. If your motherboard uses eight DIMMS, you must remove the optional flap. To do this:
  - a. With the fan side facing you, hold the air shroud with your left hand on the main shroud component and right hand on the optional flap.
  - b. Gently twist with your right hand by lifting the fan side and lowering the other end of the optional flap.
3. Place the air shroud in your chassis with the fan side touching the edge of the fans.

### *Checking the Airflow in the Chassis*

1. Make sure there are no objects to obstruct airflow in and out of the chassis. In addition, if you are using a front bezel, make sure the bezel's filter is replaced periodically.

## 5-7 System Fans

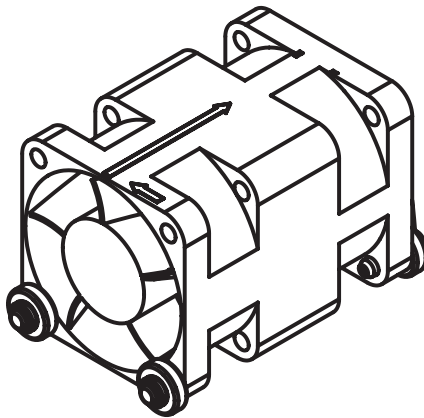

**Figure 5-13: System Fan**

Five heavy-duty fans with an optional sixth fan provide cooling for the chassis. These fans circulate air through the chassis as a means of lowering the chassis internal temperature.

In models with counter-rotating fans, each fan unit is actually made up of two fans joined back-to-back, which rotate in opposite directions. This counter-rotating action generates exceptional airflow and works to dampen vibration levels.

In chassis that provide an additional open fan housing, an additional system fan may be added for optimal cooling.

### ***Adding a System Fan***

1. Power down the system, remove the power cords from the rear of the power supplies and remove the chassis cover as described in Section 5-3.
2. Remove the dummy fan from the fan tray.
3. Place the new fan into the vacant space in the fan tray while making sure the arrows on the top of the fan (indicating air direction) point in the same direction as the arrows on the other fans.
4. Connect the fan wires to the fan headers on the motherboard.
5. Power-up the system and check that the fan is working properly before replacing the chassis cover.

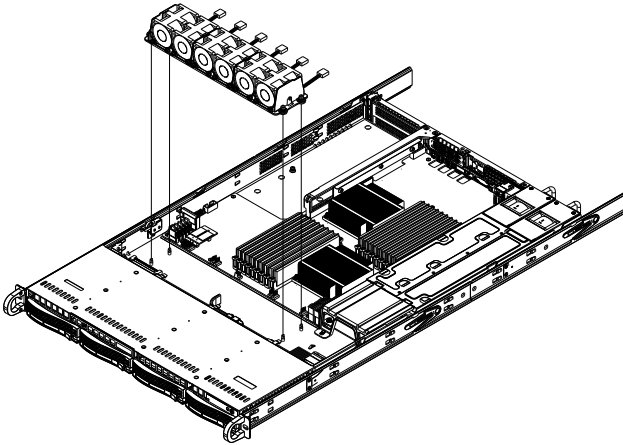

**Figure 5-14: Chassis Fans**  
(Illustration Shows Optional Sixth Fan)

The SC819 chassis includes five pre-installed fans. One extra slot is available so that an additional sixth fan may be added.

### ***Replacing a System Fan***

1. If necessary, open the chassis while the power is running to determine which fan has failed. Never run the server for an extended period of time with the chassis open.
1. Power down the system, remove the power cords from the rear of the power supplies and remove the chassis cover as described in Section 5-3.
2. Remove the failed fan's wiring from the motherboard.
3. Lift the failed fan from the chassis and pull it completely out from the motherboard.
4. Place the new fan into the vacant space in the housing while making sure the arrows on the top of the fan (indicating air direction) point in the same direction as the arrows on the other fans.
5. Reconnect the fan wires to the exact same chassis fan headers as the previous fan.
6. Reconnect the AC power cord, power up the system and check that the fan is working properly before replacing the chassis cover.

## 5-8 Power Supply

The SC819 chassis includes a 700 Watt redundant power supply. This power supply is auto-switching capable. The power supply automatically senses and operates at a 100V to 240V input voltage. An amber light will be illuminated on the power supply when the power is off. An illuminated green light indicates that the power supply is operating.

### Power Supply Failure

If either of the two power supply units fail, the remaining power supply will take over for the failed unit. The failed power supply can be replaced without having to power-down the server.

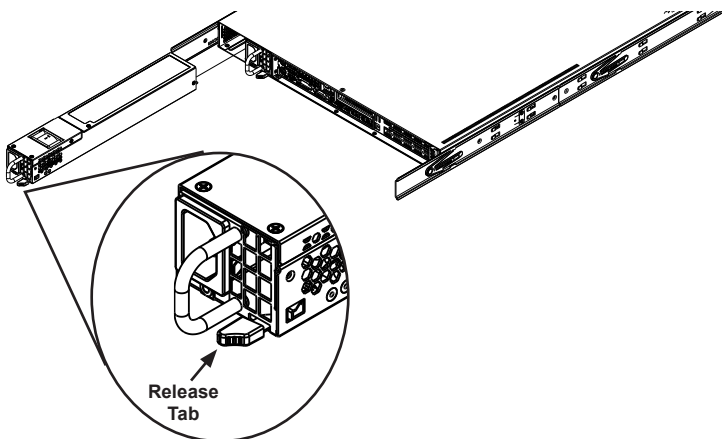

Figure 5-15: Removing the Power Supply

### Replacing the Power Supply

1. While the server is running, push the release tab on the back of the power supply as illustrated.
2. Pull the failed power supply out using the handle provided.
3. Replace the failed power module with a power supply of the same model.
4. Push the new power supply module into the power bay until it clicks into the locked position.
5. Plug the AC power cord into the module.

## 5-9 Routing the I<sup>2</sup>C Cables

It is necessary to correctly route the I<sup>2</sup>C cables to avoid interference due to noise on the I<sup>2</sup>C lines. Using tie wraps, secure the I<sup>2</sup>C cables to the large black power switching cable to keep it close to the power supply and away from the motherboard.

## Notes



## Chapter 6

# Rack Installation

### 6-1 Overview

This chapter provides a quick rack setup. Following these steps in the order given should enable you to have the system operational within a minimum amount of time.

### 6-2 Unpacking the System

You should inspect the box the chassis was shipped in and note if it was damaged in any way. If the chassis itself shows damage you should file a damage claim with the carrier who delivered it.

Decide on a suitable location for the rack unit that will hold your chassis. It should be situated in a clean, dust-free area that is well ventilated. Avoid areas where heat, electrical noise and electromagnetic fields are generated. You will also need it placed near a grounded power outlet. Be sure to read the Rack Cautions and General Server Cautions in the next section of this manual.

### 6-3 Preparing for Setup

The box your chassis was shipped in should include two sets of rail assemblies, two rail mounting brackets and the mounting screws needed to install the system into a rack. Please read this section in its entirety before you begin the installation procedure outlined in the sections that follow.

#### Choosing a Setup Location

- Leave enough clearance in front of the rack to enable you to open the front door completely (twenty-five inches).
- Leave approximately thirty inches of clearance in the back of the rack to allow for sufficient airflow and ease in servicing.
- This product is for installation only in a Restricted Access Location (dedicated equipment rooms, service closets and the like).

## Rack Precautions

- Ensure that the leveling jacks on the bottom of the rack are fully extended to the floor with the full weight of the rack resting on them.
- In single rack installations, stabilizers should be attached to the rack.
- In multiple rack installations, the racks should be coupled together.
- Always make sure the rack is stable before extending a component from the rack.
- You should extend only one component at a time. Extending two or more simultaneously may cause the rack to become unstable.

## General Server Precautions

- Review the electrical and general safety precautions that came with the components you are adding to your chassis.
- Determine the placement of each component in the rack *before* you install the rails.
- Install the heaviest server components on the bottom of the rack first, and then work up.
- Use a regulating uninterruptable power supply (UPS) to protect the server from power surges, voltage spikes and to keep your system operating in case of a power failure.
- Allow the hot-swappable hard drives and power supply modules to cool before touching them.
- Always keep the rack's front door and all panels and components on the servers closed when not servicing to maintain proper cooling.

## Rack Mounting Considerations

### Ambient Operating Temperature

If installed in a closed or multi-unit rack assembly, the ambient operating temperature of the rack environment may be greater than the ambient temperature of the room. Therefore, consideration should be given to installing the equipment in an environment compatible with the manufacturer's maximum rated ambient temperature (Tmra).

### Reduced Airflow

Equipment should be mounted into a rack so that the amount of airflow required for safe operation is not compromised.

### Mechanical Loading

Equipment should be mounted into a rack so that a hazardous condition does not arise due to uneven mechanical loading.

### Circuit Overloading

Consideration should be given to the connection of the equipment to the power supply circuitry and the effect that any possible overloading of circuits might have on overcurrent protection and power supply wiring. Appropriate consideration of equipment nameplate ratings should be used when addressing this concern.

### Reliable Ground

A reliable ground must be maintained at all times. To ensure this, the rack itself should be grounded. Particular attention should be given to power supply connections other than the direct connections to the branch circuit, such as the use of power strips and other devices.



To prevent bodily injury when mounting or servicing this unit in a rack, you must take special precautions to ensure that the system remains stable. The following guidelines are provided to ensure your safety:

- This unit should be mounted at the bottom of the rack if it is the only unit in the rack.
- When mounting this unit in a partially filled rack, load the rack from the bottom to the top with the heaviest component at the bottom of the rack.
- If the rack is provided with stabilizing devices, install the stabilizers before mounting or servicing the unit in the rack.

## 6-4 Rack Mounting Instructions

This section provides information on installing the SC819 chassis into a rack unit. There are a variety of rack units on the market, which may mean the assembly procedure will differ slightly. You should also refer to the installation instructions that came with the rack unit you are using.

**NOTE:** This rail will fit a rack between 26" and 33.5" deep.

### Identifying the Sections of the Rail Assemblies

The chassis package includes rail assemblies in the rack mounting kit. Each assembly consists of two sections, an inner rail and an inner rail extension which mount directly onto the chassis, and an outer rail which is secured to the rack.

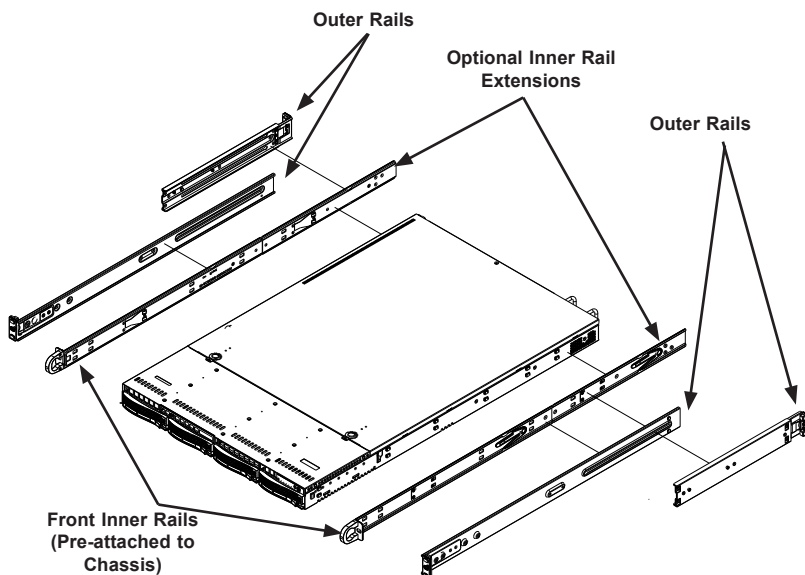

**Figure 6-1: Identifying the Sections of the Rail Assemblies**



Warning: do not pick up the server by the front handles. They are designed to pull the system from a rack only.

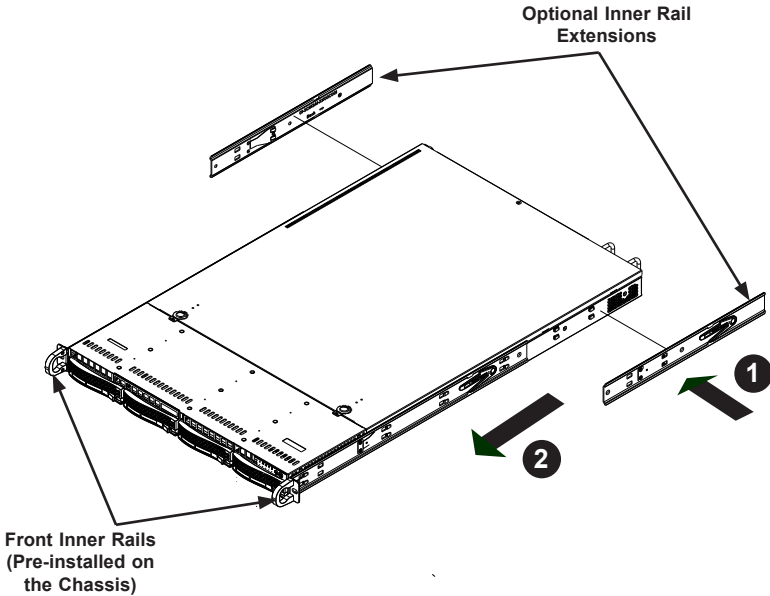

**Figure 6-2: Installing the Optional Inner Rail Extensions**

## Optional Inner Rail Extensions

The SC819 chassis includes a set of inner rails which are in two sections, front inner rails and optional inner rail extensions. The inner rails are pre-attached and do not interfere with normal use of the chassis if you decide not to use a server rack. Attach the optional inner rail extension to extend the chassis from the rack.

### *Installing the Inner Rail Extensions*

1. Place the inner rail extensions on the side of the chassis aligning the hooks of the chassis with the inner rail extension holes. Ensure that the inner rail extension faces "outward" just like the pre-attached inner rail.
2. Slide the extension toward the front of the chassis.
3. Secure the inner rail extension with two screws.
4. Repeat steps 1-3 for the other inner rail extension.

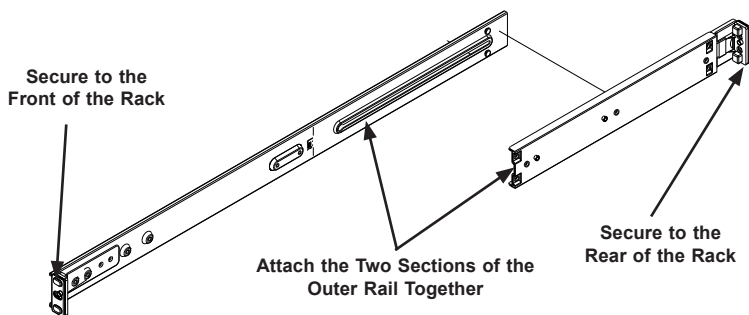

**Figure 6-3: Assembling the Outer Rails**

### ***Installing the Outer Rails to the Rack***

1. Attach the shorter section of the outer rail to the outside of the longer section of the outer rail. You must align the pins with the slides. Both ends of the outer rail must face the same direction in order to be secured to the rack.
2. Adjust both sections of the outer rail to the proper length so that the rail fits snugly within the rack.
3. Secure the longer section of the outer rail to the front of the rack with two M5 screws, and the shorter section to the rear side of the rack with two M5 screws.
4. Repeat steps 1-3 for the remaining outer rail.

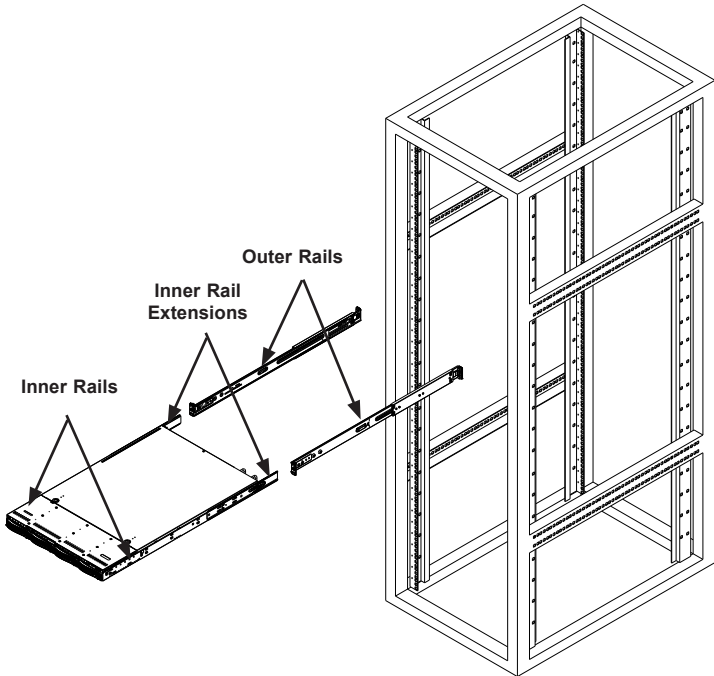

**Figure 6-4: Installing the Chassis into a Rack**

### ***Installing the Chassis into a Rack***

1. Confirm that the inner rails and rail extensions have been attached to the chassis. Confirm that the outer rails are installed on the rack.
2. Align the end of the inner rail extensions with the front of the out rails.
3. Slide the inner rails into the outer rails, keeping the pressure even on both sides. It may be necessary to depress the locking tabs when inserting the inner rails. When the server has been pushed completely into the rack, the locking tabs will "click" into the locked position.
4. (Optional) Insert and tighten the thumbscrews that hold the front of the server to the rack.



Stability hazard. The rack stabilizing mechanism must be in place, or the rack must be bolted to the floor before you slide the unit out for servicing. Failure to stabilize the rack can cause the rack to tip over.

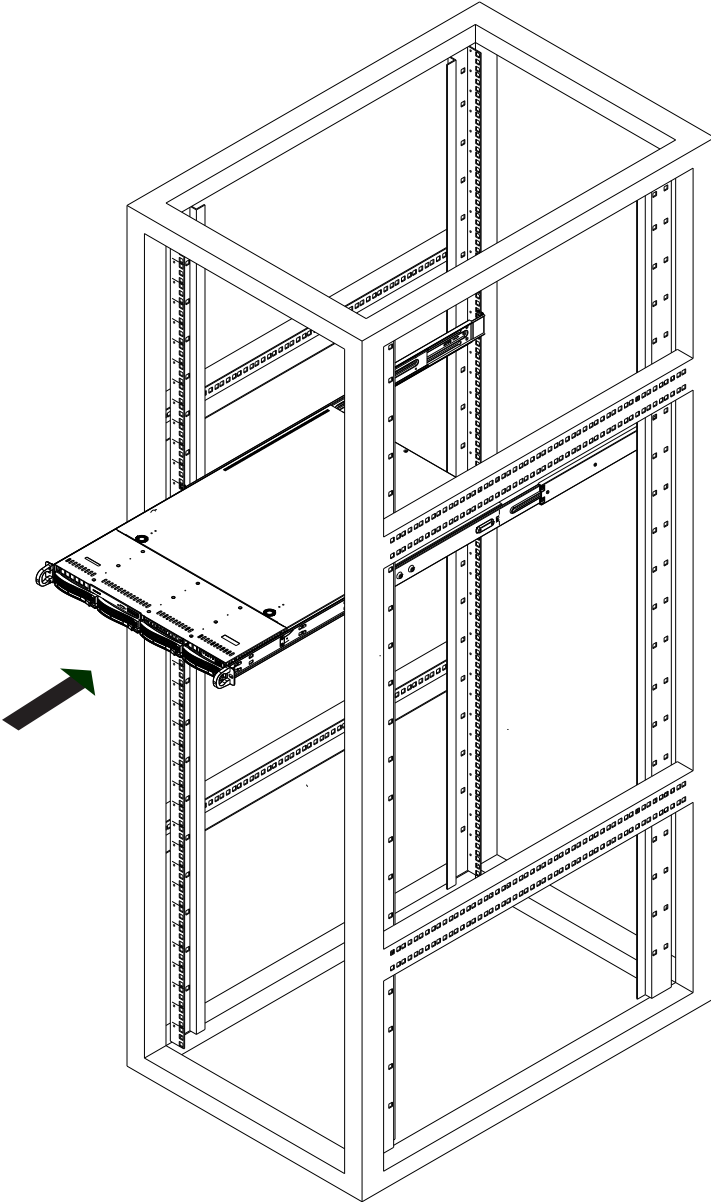

**Figure 6-5: Installing the Chassis into the Rack**

Note: figures are for illustrative purposes only. Servers should always be installed in racks from the bottom up.



## Appendix A

### Chassis Cables

#### A-1 Overview

This appendix lists supported cables for your chassis system. It only includes the most commonly used components and configurations. For more compatible cables, refer to the manufacturer of the motherboard you are using and our web site at [www.supermicro.com](http://www.supermicro.com).

#### A-2 Cables Included with SC819 Chassis Models

SC819TQ-R700UB			
Part #	Type	Length	Description
CBL-0157L	Round ribbon cable	9"	8-pin to 8-pin ribbon cable for SGPIO
CBL-0191L	Round control cable	19.5"	20-pin to 20-pin cable
CBL-0180L-01	Round cable	Varies	Set of four SATA 70/59/48/38 cm round cables
CBL-0139L	Round cable	Varies	Set of SATA 70/59/48/38 cm round cables

SC819TQ-R700WB			
Part #	Type	Length	Description
CBL-0157L	Round ribbon cable	9"	8-pin to 8-pin ribbon cable for SGPIO
CBL-0180L-01	Round cable	Varies	Set of four SATA 70/59/48/38 cm round cables

## A-4 Compatible Cables

These cables are compatible with the SC819 chassis.

### Alternate SAS/SATA Cables

Some compatible motherboards have different connectors. If your motherboard has only one SAS connector that the SAS/SATA cables must share, use one of the following cables. These cables must be purchased separately.

**Cable Name:** SAS Cable

**Quantity:** 1

**Part #:** CBL-0175L

**Alt. Name:** "Big Four"

Description: This cable has one SFF-8484 (32-pin) connector on one end and four SAS connectors with seven pins each at the other. This cable connects from the host (motherboard or other controller) to the backplane SAS hard drive port.

**Cable Name:** SAS Cable

**Quantity:** 1

**Part #:** CBL-0116

**Alt. Name:** iPass or "Small Four"

Description: This cable has one iPass (SFF-8087/Mini-SAS) connector (36-pin) at one end and four SAS connectors on the other end. This cable connects from the host (motherboard or other controller) to the backplane SAS hard drive port.

## Extending Power Cables

Although Supermicro chassis are designed with to be efficient and cost-effective, some compatible motherboards have power connectors located in different areas.

To use these motherboards you may have to extend the power cables to the mother boards. To do this, use the following chart as a guide.

Power Cable Extenders		
Number of Pins	Cable Part #	Length
24-pin	CBL-0042	7.9" (20 cm)
20-pin	CBL-0059	7.9" (20 cm)
8-pin	CBL-0062	7.9" (20 cm)
4-pin	CBL-0060	7.9" (20 cm)

## Front Panel to the Motherboard

The SC819 chassis includes a cable to connect the chassis front panel to the motherboard. If your motherboard uses a different connector, use the following list to find a compatible cable.

Front Panel to Motherboard Cable (Ribbon Cable)		
Number of Pins (Front Panel)	Number of Pins (Motherboard)	Cable Part #
16-pin	16-pin	CBL-0049
16-pin	20-pin	CBL-0048
20-pin	20-pin	CBL-0047
16-pin	Split*	CBL-0068
20-pin	Split*	CB -0067

\*Split cables: Use these cables if your motherboard has different pin definitions than a Supmicro motherboard.

## A-5 Chassis Screws

The accessory box includes all the screws needed to set up the chassis. This section lists and describes the most common screws used. Your chassis may not require all the parts listed.

### M/B



Pan head  
6-32 x 5 mm  
[0.197]

### HARD DRIVE



Flat head  
6-32 x 5 mm  
[0.197]

### DVD-ROM, CD-ROM, and FLOPPY DRIVE



Pan head  
6-32 x 5 mm  
[0.197]



Flat head  
6-32 x 5 mm  
[0.197]



Round head  
M3 x 5 mm  
[0.197]



Round head  
M2.6 x 5 mm  
[0.197]

### RAIL



Flat head  
M4 x 4 mm  
[0.157]



Round head  
M4 x 4 mm  
[0.157]



Flat head  
M5 x 12 mm [0.472]  
Washer for M5



### M/B STANDOFFS



M/B standoff  
6-32 to 6-32



M/B (CPU)  
standoff  
M5 to 6-32



Thumb screw  
6-32 x 5 mm  
[0.197]



1/2 M/B standoff  
6-32 x 5 mm  
[0.197]



## Appendix B

### SC819 Power Supply Specifications

This appendix lists power supply specifications for your chassis system.

<b>Power Supply Specifications</b>	
<b>700W</b>	
<b>MFR Part #</b>	PWS-703P-1R
<b>AC Input</b>	700W: 100-140 V, 50-60 Hz, 8.5-6 Amp 750W: 180-240 V, 60-50 Hz, 5-3.8 Amp
<b>DC Output +5V standby</b>	3 Amp
<b>DC Output +12V</b>	700W: 58 Amp at 100-140V 750W: 62 Amp at 180-240V
<b>With Power Distributor</b>	+5V: 25 Amp +3.3V: 25 Amp -12V: 0.6 Amp

**Notes**

## Appendix C

### SAS-815TQ Backplane Specifications

To avoid personal injury and property damage, carefully follow all the safety steps listed below when accessing your system or handling the components.

#### C-1 ESD Safety Guidelines

Electrostatic Discharge (ESD) can damage electronic components. To prevent damage to your system, it is important to handle it very carefully. The following measures are generally sufficient to protect your equipment from ESD.

- Use a grounded wrist strap designed to prevent static discharge.
- Touch a grounded metal object before removing a component from the antistatic bag.
- Handle the backplane by its edges only; do not touch its components, peripheral chips, memory modules or gold contacts.
- When handling chips or modules, avoid touching their pins.
- Put the card and peripherals back into their antistatic bags when not in use.

#### C-2 General Safety Guidelines

- Always disconnect power cables before installing or removing any components from the computer, including the SAS-815TQ backplane.
- Disconnect the power cable before installing or removing any cables from the SAS-815TQ backplane.
- Make sure that the SAS-815TQ backplane is securely and properly installed on the motherboard to prevent damage to the system due to power shortage.

### **C-3 An Important Note to Users**

All images and layouts shown in this user's guide are based upon the latest PCB Revision available at the time of publishing. The card you have received may or may not look exactly the same as the graphics shown in this manual.

### **C-4 Introduction to the SAS-815TQ Backplane**

The SAS-815TQ backplane has been designed to utilize the most up-to-date technology available, providing your system with reliable, high-quality performance.

This manual reflects SAS-815TQ Revision 1.00, the most current release available at the time of publication. Always refer to the Supermicro Web site at [www.supermicro.com](http://www.supermicro.com) for the latest updates, compatible parts and supported configurations.



## C-5 Front Connectors

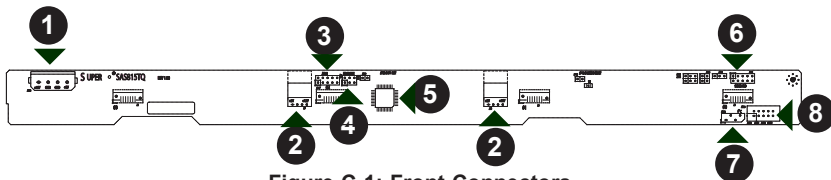

Figure C-1: Front Connectors

### Front Connectors and Components

1. Power Connectors (4-pin): JP10
2. CD-ROM/Floppy Drive Power Connector: J9 and J10
3. JTAG JP47
4. Upgrade Connector: JP46
5. MG9071 Chip
6. Sideband JP51
7. I<sup>2</sup>C Connector JP44
8. ACT\_IN JP26
9. SAS Port #0 J5
10. SAS Port #1 J6
11. SAS Port #2 J7
12. SAS Port #3 J8

### SAS Ports

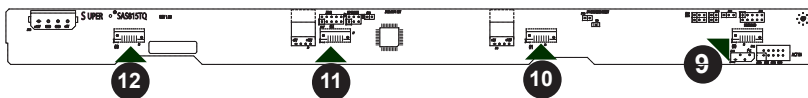

Figure C-2: SAS Ports

## C-6 Front Connector and Pin Definitions

### 1. Backplane Main Power Connectors

The 4-pin connectors, designated JP10 provide power to the backplane. See the table on the right for pin definitions.

Backplane Main Power 4-Pin Connector	
Pin#	Definition
1	+12V
2 and 3	Ground
4	+5V

### 2. CD-ROM/Floppy 4-Pin Connectors

The 4-pin connectors, designated J9 and J10, provide power to the CD-ROM and floppy drives. See the table on the right for pin definitions.

CD-ROM/ FDD Power 4-Pin Connector	
Pin#	Definition
1	+5V
2 and 3	Ground
4	+12V

### 3. - 4. JTAG Connector and Upgrade Connector

The JTAG connector, designated JP47, and the upgrade connector, designated JP46, are diagnostic purposes. These connectors should be used by a certified and experienced technician.

### 4. MG9071 Chip

The MG9071 is an enclosure management chip that supports the SES-2 controller and SES-2 protocols.

## 6. Sideband Headers

The sideband headers are designated JP51. For SES-2 to work properly, you must connect an 8-pin sideband cable. See the table to the right for pin definitions.

Sideband Headers			
Pin #	Definition	Pin #	Definition
2	Backplane Addressing (SB5)	1	Controller ID (SB6)
4	Reset (SB4)	3	GND (SB2)
6	GND (SB3)	5	SDA (SB1)
8	Backplane ID (SB7)	7	SCL (SB0)
10	No Connection	9	No Connection

## 7. I<sup>2</sup>C Connectors

The I<sup>2</sup>C Connectors, designated JP44, are used to monitor HDD activity and status. See the table on the right for pin definitions.

I <sup>2</sup> C Connector Pin Definitions	
Pin#	Definition
1	Data
2	Ground
3	Clock
4	No Connection

## 8. Activity LED Header

The activity LED header, designated JP26, is used to indicate the activity status of each SAS drive. For the Activity LED Header to work properly, connect using a 10-pin LED cable.

SAS Activity LED Header Pin Definitions			
Pin #	Definition	Pin #	Definition
1	ACT IN#0	6	ACT IN#4
2	ACT IN#1	7	ACT IN#5
3	ACT IN#2	8	ACT IN#6
4	ACT IN#3	9	ACT IN#7
5	Ground	10	Empty

## 9. - 12. SAS Ports

The SAS ports are used to connect the SAS drive cables. The four ports are designated #0 - #4. Each port is also compatible with SATA drives.

## C-7 Front Jumper Locations and Pin Definitions

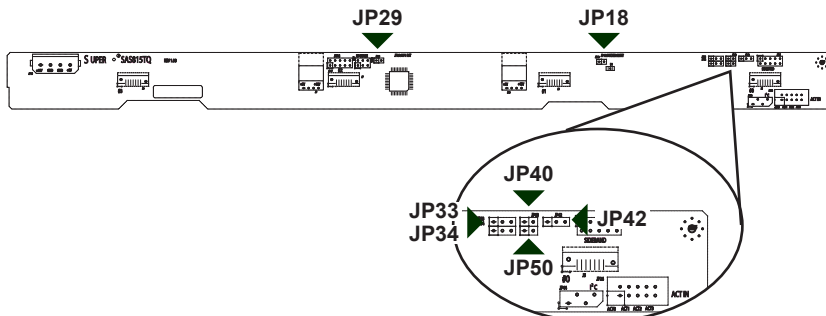
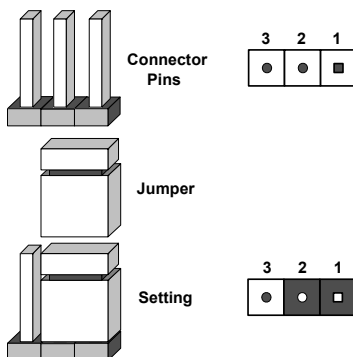

Figure C-3: Front Connectors and Jumpers

### Explanation of Jumpers

To modify the operation of the backplane, jumpers can be used to choose between optional settings. Jumpers create shorts between two pins to change the function of the connector. Pin 1 is identified with a square solder pad on the printed circuit board. Note: On two pin jumpers, "Closed" means the jumper is on and "Open" means the jumper is off the pins.



Jumper Settings		
Jumper	Jumper Settings	Note
JP18	Open: Enabled Closed: Disabled	Buzzer reset*
JP29	Open: Default Closed: Reset	MG9071 chip reset

\*The buzzer sound indicates that a condition requiring immediate attention has occurred.

**The buzzer alarm is triggered by the following conditions:**

1. Hard drive failure
2. Fan failure
3. System temperature over 45° Celsius.

## I<sup>2</sup>C and SGPIO Modes and Jumper Settings

This backplane can utilize I<sup>2</sup>C or SGPIO. I<sup>2</sup>C is the default mode and can be used without making changes to your jumpers. The following information details which jumpers must be configured to use SGPIO mode or restore your backplane to I<sup>2</sup>C mode.

I <sup>2</sup> C Setting (Default)		
Jumper	Jumper Setting	Note
JP33	Pins 2-3	Controller ID
JP34	Pins 1-2:ID#0	Backplane ID
JP40	Open	I <sup>2</sup> C Reset SD OUT
JP42	Pins 2-3	Backplane ID SDIN
JP50	Closed	I <sup>2</sup> C Reset

SGPIO Setting		
Jumper	Jumper Setting	Note
JP33	Pins 1-2	Controller ID
JP34	Pins 1-2:ID#0	Backplane ID
JP40	Closed	I <sup>2</sup> C Reset SD OUT
JP42	Pins 1-2	Backplane ID SDIN
JP50	Open	I <sup>2</sup> C Reset

## C-8 Front LED Indicators

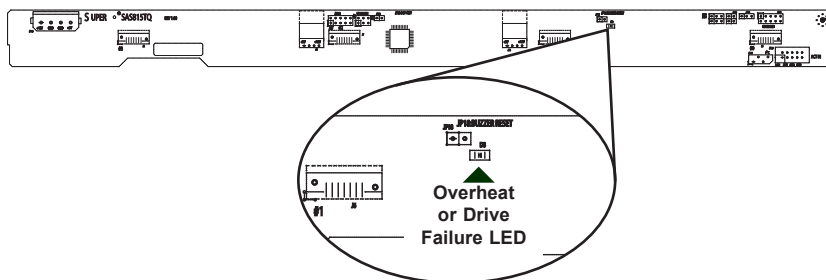

Figure C-4: Front LED Indicators

Front Panel LEDs		
LED	State	Specification
D3	On	Overheat or drive failure

## C-8 Rear Connectors and LED Indicators

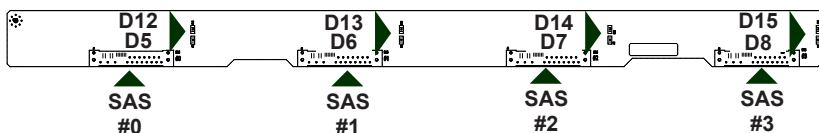

Figure C-5: Rear Connectors and LED Indicators

Rear SAS/SATA Connectors		
Rear Connector	Connector Number	SAS Drive Number
SAS #0	J1	SAS/SATA HDD #0
SAS #1	J2	SAS/SATA HDD #1
SAS #2	J3	SAS/SATA HDD #2
SAS #3	J4	SAS/SATA HDD #3

Rear LED Indicators		
Rear Connector	Hard Drive Activity	Failure LED
SAS #0	D12	D5
SAS #1	D13	D6
SAS #2	D14	D7
SAS #3	D15	D8

## Notes

Disclaimer (cont.)

The products sold by Supermicro are not intended for and will not be used in life support systems, medical equipment, nuclear facilities or systems, aircraft, aircraft devices, aircraft/emergency communication devices or other critical systems whose failure to perform be reasonably expected to result in significant injury or loss of life or catastrophic property damage. Accordingly, Supermicro disclaims any and all liability, and should buyer use or sell such products for use in such ultra-hazardous applications, it does so entirely at its own risk. Furthermore, buyer agrees to fully indemnify, defend and hold Supermicro harmless for and against any and all claims, demands, actions, litigation, and proceedings of any kind arising out of or related to such ultra-hazardous use or sale.