

SUPERO[®]

SC828 Chassis Series



SC828TQ-R1000LPB
SC828TQ-R1200LPB

USER'S MANUAL

1.0

The information in this User's Manual has been carefully reviewed and is believed to be accurate. The vendor assumes no responsibility for any inaccuracies that may be contained in this document, makes no commitment to update or to keep current the information in this manual, or to notify any person or organization of the updates. **Please Note: For the most up-to-date version of this manual, please see our web site at www.supermicro.com.**

Super Micro Computer, Inc. ("Supermicro") reserves the right to make changes to the product described in this manual at any time and without notice. This product, including software, if any, and documentation may not, in whole or in part, be copied, photocopied, reproduced, translated or reduced to any medium or machine without prior written consent.

IN NO EVENT WILL SUPERMICRO BE LIABLE FOR DIRECT, INDIRECT, SPECIAL, INCIDENTAL, SPECULATIVE OR CONSEQUENTIAL DAMAGES ARISING FROM THE USE OR INABILITY TO USE THIS PRODUCT OR DOCUMENTATION, EVEN IF ADVISED OF THE POSSIBILITY OF SUCH DAMAGES. IN PARTICULAR, SUPERMICRO SHALL NOT HAVE LIABILITY FOR ANY HARDWARE, SOFTWARE, OR DATA STORED OR USED WITH THE PRODUCT, INCLUDING THE COSTS OF REPAIRING, REPLACING, INTEGRATING, INSTALLING OR RECOVERING SUCH HARDWARE, SOFTWARE, OR DATA.

Any disputes arising between manufacturer and customer shall be governed by the laws of Santa Clara County in the State of California, USA. The State of California, County of Santa Clara shall be the exclusive venue for the resolution of any such disputes. Super Micro's total liability for all claims will not exceed the price paid for the hardware product.

FCC Statement: This equipment has been tested and found to comply with the limits for a Class A digital device pursuant to Part 15 of the FCC Rules. These limits are designed to provide reasonable protection against harmful interference when the equipment is operated in a commercial environment. This equipment generates, uses, and can radiate radio frequency energy and, if not installed and used in accordance with the manufacturer's instruction manual, may cause harmful interference with radio communications. Operation of this equipment in a residential area is likely to cause harmful interference, in which case you will be required to correct the interference at your own expense.

California Best Management Practices Regulations for Perchlorate Materials: This Perchlorate warning applies only to products containing CR (Manganese Dioxide) Lithium coin cells. "Perchlorate Material-special handling may apply. See www.dtsc.ca.gov/hazardouswaste/perchlorate"

WARNING: Handling of lead solder materials used in this product may expose you to lead, a chemical known to the State of California to cause birth defects and other reproductive harm.

Manual Revision 1.0

Release Date: March 7, 2008

Unless you request and receive written permission from Super Micro Computer, Inc., you may not copy any part of this document.

Information in this document is subject to change without notice. Other products and companies referred to herein are trademarks or registered trademarks of their respective companies or mark holders.

Copyright © 2008 by Super Micro Computer, Inc.
All rights reserved.

Printed in the United States of America

Preface

About This Manual

This manual is written for professional system integrators and PC technicians. It provides information for the installation and use of the SC828 chassis. Installation and maintenance should be performed by experienced technicians only.

Supermicro's SC828 chassis features a unique and highly-optimized design. The chassis is equipped with a front-loading 1000W or 1200W high-efficiency redundant power supply. High performance fans provide ample optimized cooling.

This document lists compatible parts available when this document was published. Always refer to the our Web site for updates on supported parts and configurations.

Manual Organization

Chapter 1 Introduction

The first chapter provides a checklist of the main components included with this chassis and describes the main features of the SC828 chassis. This chapter also includes contact information.

Chapter 2 System Safety

This chapter lists warnings, precautions, and system safety. It is recommended that you thoroughly familiarize yourself with installing and servicing this chassis safety precautions.

Chapter 3 Chassis Components

Refer here for details on this chassis model including the fans, airflow shields, and other components.

Chapter 4 Chassis Setup and Installation

Follow the procedures given in this chapter when installing, removing, or reconfiguring your chassis.

Chapter 5 Rack Installation

Refer to this chapter for detailed information on chassis rack installation. You should follow the procedures given in this chapter when installing, removing or reconfiguring your chassis into a rack environment.

Appendix A Cables, Screws and other Accessories

Appendix B Power Supply Specifications

Appendix C BPN-SAS-828TQ-Backplane Specifications

Table of Contents

Chapter 1 Introduction

1-1	Overview	1-1
1-2	Shipping List.....	1-1
	Part Numbers.....	1-1
1-3	Where to get Replacement Components.....	1-2
1-4	Contacting SuperMicro.....	1-3
1-5	Returning Merchandise for Service	1-4

Chapter 2 System Safety

2-1	Overview	2-1
2-2	Warnings and Precautions	2-1
2-3	Preparing for Setup.....	2-1
2-4	Electrical Safety Precautions	2-2
2-5	General Safety Precautions	2-3
2-6	System Safety.....	2-3

Chapter 3 Chassis Components

3-1	Overview	3-1
3-2	Components.....	3-1
	Chassis.....	3-1
	Fans	3-1
	Mounting to a Rack (optional).....	3-2
	Power Supply.....	3-2
	Air Shroud.....	3-2
3-3	Where to get Replacement Components.....	3-2

Chapter 4 Chassis Setup and Installation

4-1	Removing the Chassis Cover	4-1
4-2	Installing the Motherboard into the Chassis	4-3
4-3	Removing and Installing Chassis Fans.....	4-4
4-4	Power Supply.....	4-6
	Removing the Power Supply	4-6
	Installing the Power Supply	4-8
4-5	Installing the Air Shroud.....	4-10
4-6	Removing the Hard Drive Tray and Installing a Hard Drive	4-11
4-7	Add-on Card/Expansion Slot Setup	4-14

Chapter 5 Rack Installation

5-1	Overview	5-1
5-2	Unpacking the System	5-1

5-3	Preparing for Setup.....	5-1
	Choosing a Setup Location.....	5-1
	Rack Precautions.....	5-2
	General Server Precautions.....	5-2
5-4	Rack Mounting Considerations.....	5-3
	Ambient Operating Temperature.....	5-3
	Reduced Airflow.....	5-3
	Mechanical Loading.....	5-3
	Circuit Overloading.....	5-3
	Reliable Ground.....	5-3
5-5	Rack Mounting Instructions.....	5-4
	Identifying the Sections of the Rack Rails.....	5-4
	Inner Rails.....	5-4
	Outer Rack Rails.....	5-6
	Installing the Outer Rails to the Rack:.....	5-6

Appendix A Cables, Screws, and other Accessories

Appendix B Power Supply Specifications

Appendix C BPN-SAS-828TQ Backplane Specifications

Chapter 1

Introduction

1-1 Overview

Supermicro's SC828 chassis features a unique and highly-optimized design. The chassis is equipped with a high-efficiency 1000W or 1200W redundant power supply.

1-2 Shipping List

Part Numbers

For the latest shipping lists and part numbers for your particular chassis model please visit the Supermicro Web site at <http://www.supermicro.com/>

SC828TQ-R1200B Chassis				
Model	CPU	HDD	I/O Slots	Power Supply
SC828TQ-R1200B	Intel and AMD Quad processors	6 x 3.5" Hot-swap SAS / SATA drive bays	7 x Low-profile, Full-length I/O expansion slot	1200W

SC828TQ-R1000B Chassis				
Model	CPU	HDD	I/O Slots	Power Supply
S C 8 2 8 T Q - R1000B	Intel and AMD Quad processors	6 x 3.5" Hot-swap SAS / SATA drive bays	7 x Low-profile, Full-length I/O expansion slot	1000W

1-3 Where to get Replacement Components

Though not frequently, you may need replacement parts for your system. To ensure the highest level of professional service and technical support, we strongly recommend purchasing exclusively from our Supermicro Authorized Distributors / System Integrators / Resellers. A list of Supermicro Authorized Distributors / System Integrators / Reseller can be found at: <http://www.supermicro.com>. Click the Where to Buy link.

1-4 Contacting SuperMicro

Headquarters

Address: Super Micro Computer, Inc.
980 Rock Ave.
San Jose, CA 95131 U.S.A.

Tel: +1 (408) 503-8000

Fax: +1 (408) 503-8008

Email: marketing@supermicro.com (General Information)
support@supermicro.com (Technical Support)

Web Site: www.supermicro.com

Europe

Address: Super Micro Computer B.V.
Het Sterrenbeeld 28, 5215 ML
's-Hertogenbosch, The Netherlands

Tel: +31 (0) 73-6400390

Fax: +31 (0) 73-6416525

Email: sales@supermicro.nl (General Information)
support@supermicro.nl (Technical Support)
rma@supermicro.nl (Customer Support)

Asia-Pacific

Address: Super Micro Computer, Inc.
4F, No. 232-1, Liancheng Rd.
Chung-Ho 235, Taipei County
Taiwan, R.O.C.

Tel: +886-(2) 8226-3990

Fax: +886-(2) 8226-3991

Web Site: www.supermicro.com.tw

Email: support@supermicro.com.tw (Technical Support)

Tel: 886-2-8228-1366, ext.132 or 139

1-5 Returning Merchandise for Service

A receipt or copy of your invoice marked with the date of purchase is required before any warranty service will be rendered. You can obtain service by calling your vendor for a Returned Merchandise Authorization (RMA) number. When returning to the manufacturer, the RMA number should be prominently displayed on the outside of the shipping carton, and mailed prepaid or hand-carried. Shipping and handling charges will be applied for all orders that must be mailed when service is complete.

For faster service, RMA authorizations may be requested online (<http://www.supermicro.com/support/rma/>).

Whenever possible, repack the chassis in the original Supermicro carton, using the original packaging material. If these are no longer available, be sure to pack the chassis securely, using packaging material to surround the chassis so that it does not shift within the carton and become damaged during shipping.

This warranty only covers normal consumer use and does not cover damages incurred in shipping or from failure due to the alteration, misuse, abuse or improper maintenance of products.

During the warranty period, contact your distributor first for any product problems.

Chapter 2

System Safety

2-1 Overview

This chapter provides a quick setup checklist to get your chassis up and running. Following the steps in order given should enable you to have your chassis setup and operational within a minimal amount of time. This quick set up assumes that you are an experienced technician, familiar with common concepts and terminology.

2-2 Warnings and Precautions

You should inspect the box the chassis was shipped in and note if it was damaged in any way. If the chassis itself shows damage, file a damage claim with carrier who delivered your system.

Decide on a suitable location for the rack unit that will hold that chassis. It should be situated in a clean, dust-free area that is well ventilated. Avoid areas where heat, electrical noise and electromagnetic fields are generated.

You will also need it placed near at least one grounded power outlet. When configured, the SC828 chassis includes one power supply.

2-3 Preparing for Setup

The SC828 Chassis bolts directly to a rack and includes the mounting screws you will need to install the systems into the rack. Please read this manual in its entirety before you begin the installation procedure.

2-4 Electrical Safety Precautions

Basic electrical safety precautions should be followed to protect yourself from harm and the SC828 from damage:

- Be aware of the locations of the power on/off switch on the chassis as well as the room's emergency power-off switch, disconnection switch or electrical outlet. If an electrical accident occurs, you can then quickly remove power from the system.
- Do not work alone when working with high voltage components.
- Power should always be disconnected from the system when removing or installing main system components, such as the serverboard, memory modules and the DVD-ROM and floppy drives (not necessary for hot swappable drives). When disconnecting power, you should first power down the system with the operating system and then unplug the power cords from all the power supply modules in the system.
- When working around exposed electrical circuits, another person who is familiar with the power-off controls should be nearby to switch off the power, if necessary.
- Use only one hand when working with powered-on electrical equipment. This is to avoid making a complete circuit, which will cause electrical shock. Use extreme caution when using metal tools, which can easily damage any electrical components or circuit boards they come into contact with.
- Do not use mats designed to decrease electrostatic discharge as protection from electrical shock. Instead, use rubber mats that have been specifically designed as electrical insulators.
- The power supply power cord must include a grounding plug and must be plugged into grounded electrical outlets.
- Serverboard Battery: CAUTION - There is a danger of explosion if the onboard battery is installed upside down, which will reverse its polarities This battery must be replaced only with the same or an equivalent type recommended by the manufacturer. Dispose of used batteries according to the manufacturer's instructions.

- DVD-ROM Laser: CAUTION - This server may have come equipped with a DVD-ROM drive. To prevent direct exposure to the laser beam and hazardous radiation exposure, do not open the enclosure or use the unit in any unconventional way.

2-5 General Safety Precautions

- Keep the area around the chassis clean and free of clutter.
- Place the chassis top cover and any system components that have been removed away from the system or on a table so that they won't accidentally be stepped on.
- While working on the system, do not wear loose clothing such as neckties and unbuttoned shirt sleeves, which can come into contact with electrical circuits or be pulled into a cooling fan.
- Remove any jewelry or metal objects from your body, which are excellent metal conductors that can create short circuits and harm you if they come into contact with printed circuit boards or areas where power is present.
- After accessing the inside of the system, close the system back up and secure it to the rack unit with the retention screws after ensuring that all connections have been made.

2-6 System Safety

Electrostatic discharge (ESD) is generated by two objects with different electrical charges coming into contact with each other. An electrical discharge is created to neutralize this difference, which can damage electronic components and printed circuit boards. The following measures are generally sufficient to neutralize this difference before contact is made to protect your equipment from ESD:

- Do not use mats designed to decrease electrostatic discharge as protection from electrical shock. Instead, use rubber mats that have been specifically designed as electrical insulators.
- Use a grounded wrist strap designed to prevent static discharge.
- Keep all components and printed circuit boards (PCBs) in their antistatic bags until ready for use.

- Touch a grounded metal object before removing any board from its antistatic bag.
- Do not let components or PCBs come into contact with your clothing, which may retain a charge even if you are wearing a wrist strap.
- Handle a board by its edges only; do not touch its components, peripheral chips, memory modules or contacts.
- When handling chips or modules, avoid touching their pins.
- Put the serverboard and peripherals back into their antistatic bags when not in use.
- For grounding purposes, make sure your computer chassis provides excellent conductivity between the power supply, the case, the mounting fasteners and the serverboard.

Chapter 3

Chassis Components

3-1 Overview

This chapter describes the most common components included with your chassis. Some components listed may not be included or compatible with your particular chassis model. For more information, see the installation instructions detailed later in this manual.

3-2 Components

Chassis

You SC828 chassis comes equipped with the following:

- 6x 3.5" hot-swappable SAS / SATA drive bays
- 7x low-profile, full-length I/O expansion slots
- Slim DVD ROM drive
- Front USB + COM port.

For the latest shipping lists, visit our Web site at: <http://www.supermicro.com>.

This chassis accepts six system cooling fans and one power supply. SC828 models come in black.

Fans

The SC828 chassis accepts six 6500 RPM system fans.

Mounting to a Rack (optional)

The SC828 can be placed in a rack for secure storage and use. To setup your rack, follow the step-by-step instructions included in this manual.

Power Supply

Each SC828 chassis model includes a high-efficiency power supply with thermal control fan, rated at 1000 or 1200 Watts. In the unlikely event your power supply fails, replacement is simple. The power supply simply needs to be unscrewed from the chassis and replaced.

Air Shroud

Air shrouds are shields, usually plastic, that funnel air directly to where it is needed. Always use the air shroud included with your chassis.

3-3 Where to get Replacement Components

Though not frequently, you may need replacement parts for your system. To ensure the highest level of professional service and technical support, we strongly recommend purchasing exclusively from our Supermicro Authorized Distributors/System Integrators/Resellers. A list of Supermicro Authorized Distributors/System Integrators/Resellers can be found at: <http://www.supermicro.com>. Click the Where to Buy link.

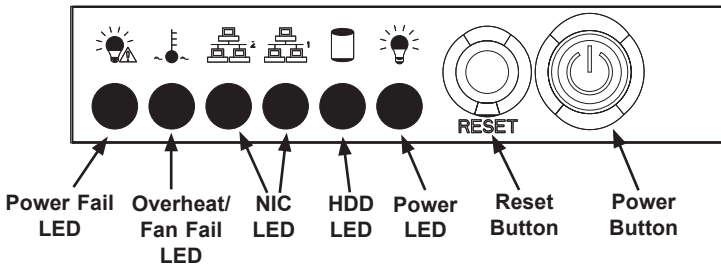
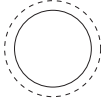

Figure 3-1 Front Panel LEDs and Buttons

3-2 Control Panel Buttons

There are two push-buttons located on the front of the chassis. These are (in order from left to right) a reset button and a power on/off button.

RESET



- **Reset:** The reset button is used to reboot the system.

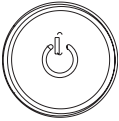

- **Power:** The main power switch is used to apply or remove power from the power supply to the server system. Turning off system power with this button removes the main power but keeps standby power supplied to the system. Therefore, you must unplug system before servicing.

3-3 Control Panel LEDs

The control panel located on the front of the SC811 chassis has five LEDs. These LEDs provide you with critical information related to different parts of the system. This section explains what each LED indicates when illuminated and any corrective action you may need to take.



- **Power Fail:** Indicates a power failure to the system's power supply units.



- **Overheat/Fan Fail:** When this LED flashes it indicates a fan failure. When continuously on (not flashing) it indicates an overheat condition, which may be caused by cables obstructing the airflow in the system or the ambient room temperature being too warm. Check the routing of the cables and make sure all fans are present and operating normally. You should also check to make sure that the chassis covers are installed. Finally, verify that the heatsinks are installed properly. This LED will remain flashing or on as long as the overheat condition exists.



- **NIC2:** Indicates network activity on GLAN2 when flashing.



- **NIC1:** Indicates network activity on GLAN1 when flashing.



- **HDD:** Indicates IDE channel activity. SAS/SATA drive, SCSI drive, and/or DVD-ROM drive activity when flashing.



- **Power:** Indicates power is being supplied to the system's power supply units. This LED should normally be illuminated when the system is operating.

Chapter 4

Chassis Setup and Installation

4-1 Removing the Chassis Cover

Before installing any components, replacing chassis fans or accessing the motherboard, you will first need to remove the top cover from the chassis.

Removing the Chassis Cover

1. Unplug the power cord from the chassis.
2. Using a Philips screw driver, remove two screws from each side of the top cover as shown below.
3. Press the two release tabs on the top of the cover.
4. Slide the cover back.
5. Lift the cover upwards

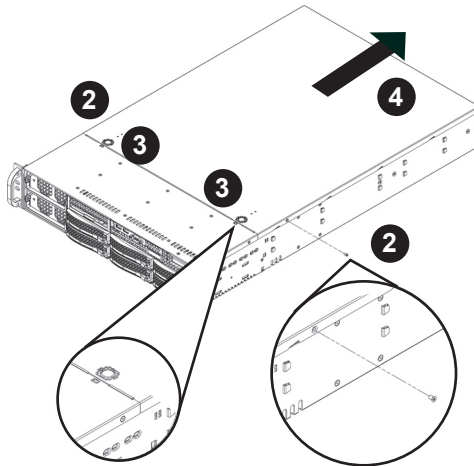

Figure 4-1 Removing the Chassis Cover

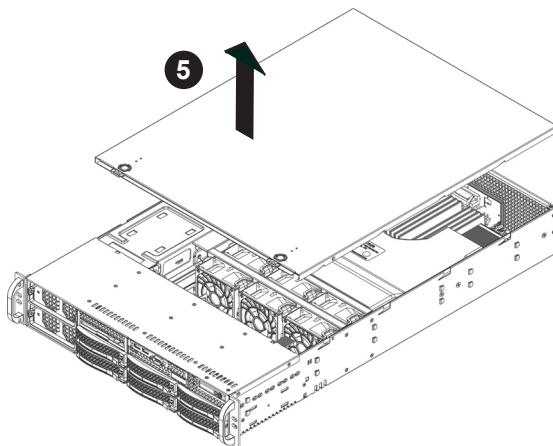

Figure 4-2 Lifting the Chassis Cover

4-2 Installing the Motherboard into the Chassis

Installing the Motherboard

1. Ensure that the power cord has been unplugged from the chassis.
2. Locate the mounting holes on the motherboard and the mounting holes on the chassis.
3. Align the mounting holes on the motherboard against the corresponding mounting holes on the chassis. The SC828 chassis comes with removable motherboard standoffs. These will need to be adjusted to each individual motherboard. Once aligned, place the motherboard on top of the chassis. If using a heatsink with the motherboard, refer to the motherboard manual for further instructions.
4. Using a Philips screw driver, install a 6-32 screw into each mounting hole to secure the motherboard onto the chassis.

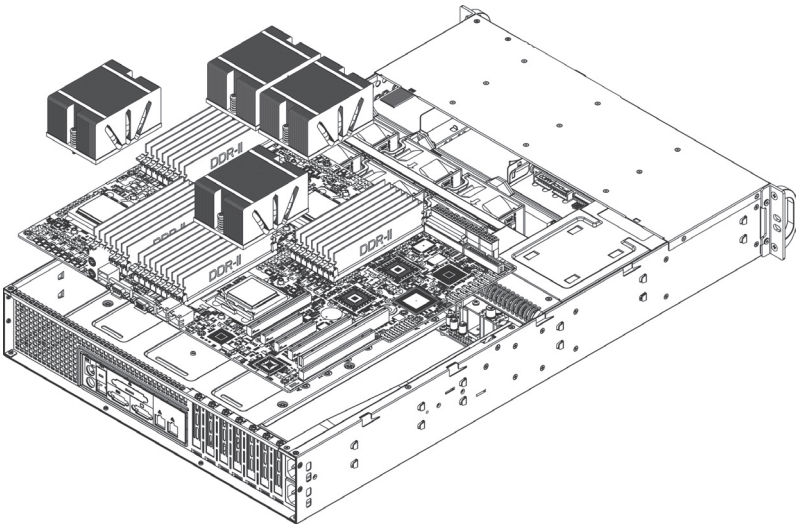

Figure 4-3 Installing the Motherboard

4-3 Removing and Installing Chassis Fans

The SC828 chassis comes equipped with six 6500 RPM fans for optimal cooling. In the unlikely event that a fan needs to be replaced, removing and installing chassis fans is a simple procedure.

Removing a Chassis Fan

1. If necessary, open the chassis while the power is running to determine which fan has failed. (Never run the server for an extended period of time with the chassis open.)
2. Turn off the power to the system and unplug the system from the outlet.
3. Disconnect the fan wiring from the connectors.
4. Press the release tab on the side of the fan housing
5. Carefully lift the fan up and out of the chassis.

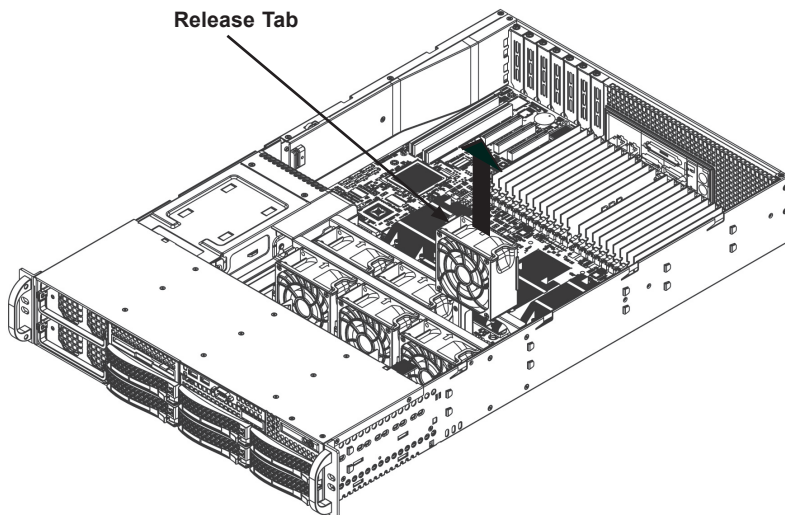

Figure 4-4 Removing a Chassis Fan

Installing a Chassis Fan

1. Turn off the power to the system and unplug the system from the outlet.
2. Slide the fan housing into the chassis fan mounting bracket.
3. Push down gently on the top of the fan until it clicks into place
4. Reconnect the fan wiring to the connectors.

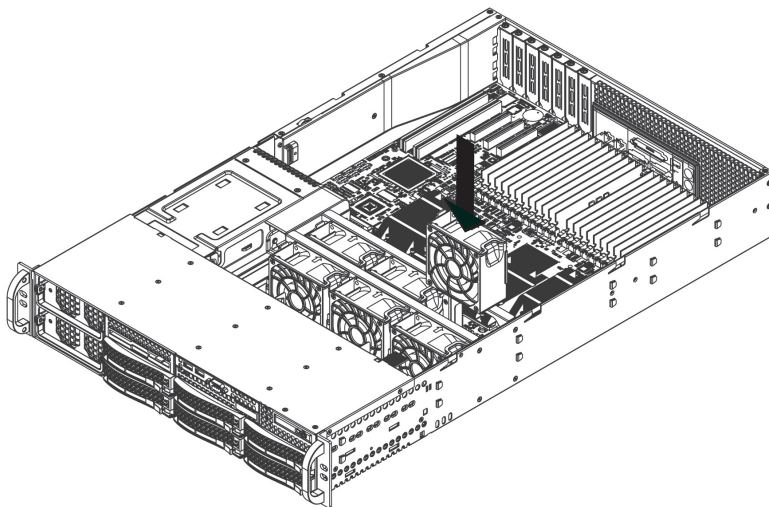

Figure 4-5 Installing a Chassis Fan

4-4 Power Supply

The SC828 chassis has a 1000 or 1200 Watt power supply. This power supply is auto-switching capable. This enables it to automatically sense and operate at a 100v to 240v input voltage.

The SC828 chassis has two power supplies. In the unlikely event that a power supply unit fails, the system will shut down and you will need to change the power supply unit.

New units can be ordered directly from Supermicro (see contact information in the Preface).

Removing the Power Supply

Power Supply Removal

1. Unplug all power leading to the chassis.

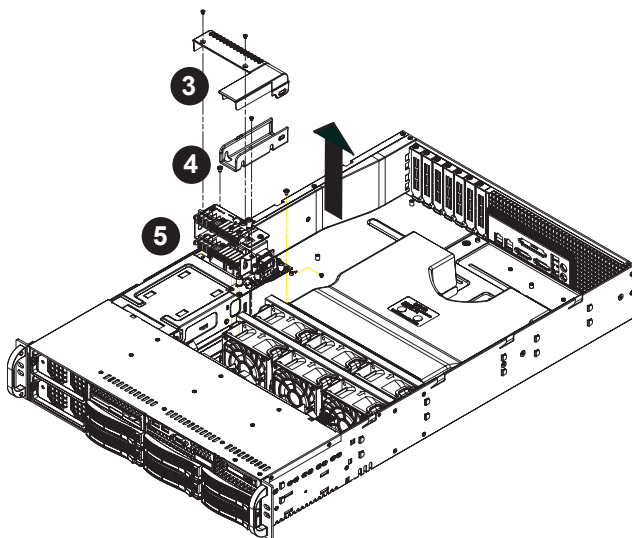

Figure 4-6 Removing the Power Cord Channel Assembly

2. Disconnect all wiring from the power supply.
3. Remove the two screws which hold the power cord channel cover in place and the power cord channel cover off of the power cord channel.
4. Remove the single screw securing the power cord channel to the power distributor and lift it off of the power distributor.
5. Remove the two mounting screws which secure the power distributor to the floor of the chassis and lift it out of the chassis.

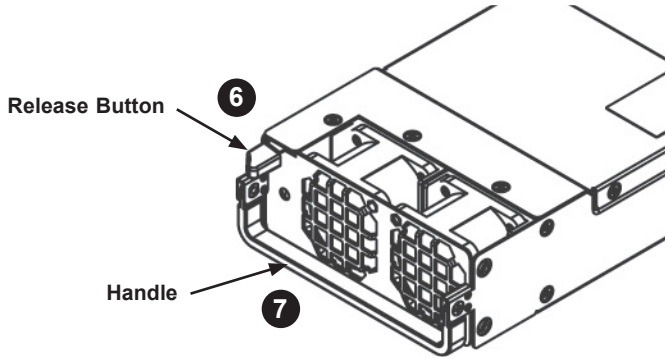

Figure 4-7 Releasing the Power Supply

6. On the front of the chassis, press the release button on the front face of the power supply.
7. Lift the handle upwards
8. Gently pull the power supply forward and out of the chassis.
9. Ensure that all screws are set aside for later use when installing the replacement power supply.

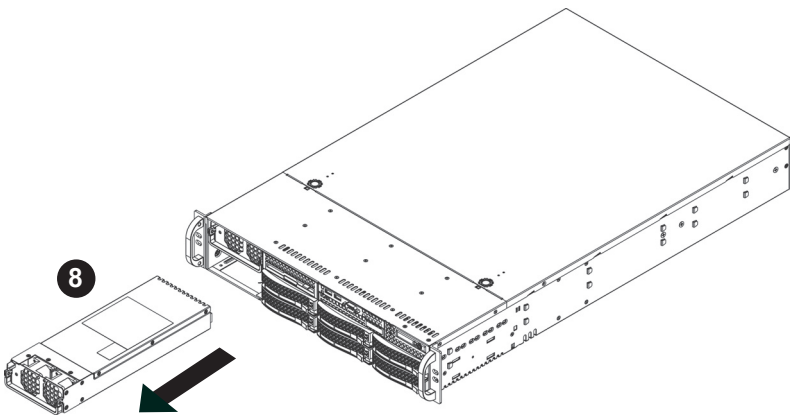

Figure 4-8 Removing the Power Supply

Installing the Power Supply

Power Supply Installation

1. Unplug all power leading to the chassis.
2. Using the screws previously set aside, secure the power distributor to the floor of the chassis.

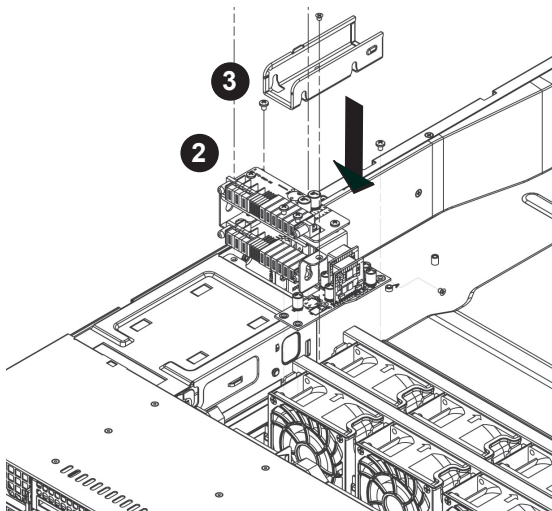

Figure 4-9 Replacing the Power Distributor and Power Cord Channel

3. Reattach the power cord channel to the power distributor
4. Connect the power cord to the power supply and run the cord through the power cord channel and out of the chassis.

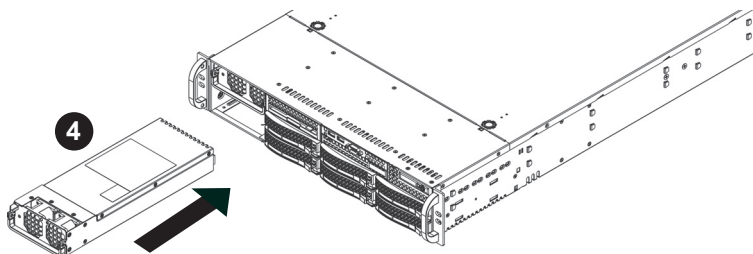

Figure 4-10 Replacing the Power Supply

5. Replace the power cord channel cover on the power cord channel.
6. Insert the power supply into its slot in the front of the chassis, gently pushing it back into the chassis until it clicks into position.

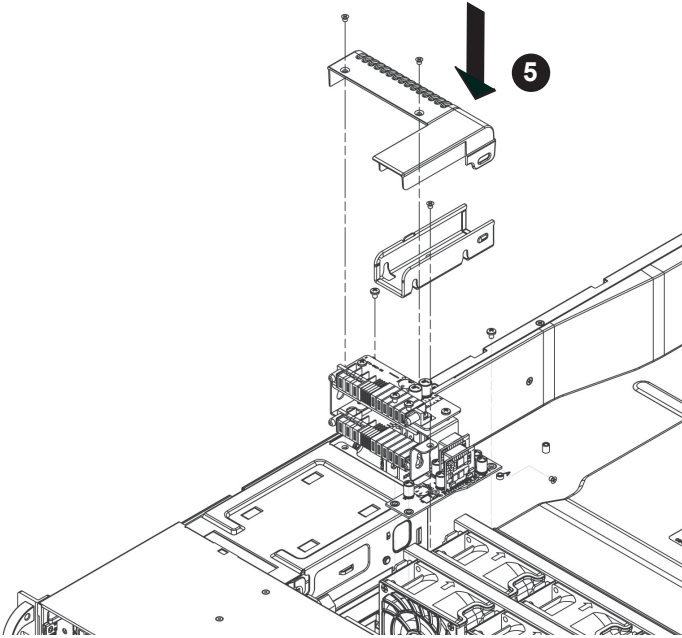

Figure 4-11 Replacing the Power Cord Channel Cover

4-5 Installing the Air Shroud

The air shroud is used to channel the air flow from the system fans and direct it into critical areas of the chassis that require cooling. The SC828 chassis comes equipped with an adjustable air shroud, which allows the direction of the airflow to be fine-tuned for optimal cooling. No tools are required to install or adjust the air shroud.

Installing and Adjusting the Air Shroud:

1. Adjust the air channel arcs on the underside of the air shroud as necessary for optimal cooling.
2. Carefully slide the air shroud into the chassis so that it covers the system fans and directs the air flow into the chassis.

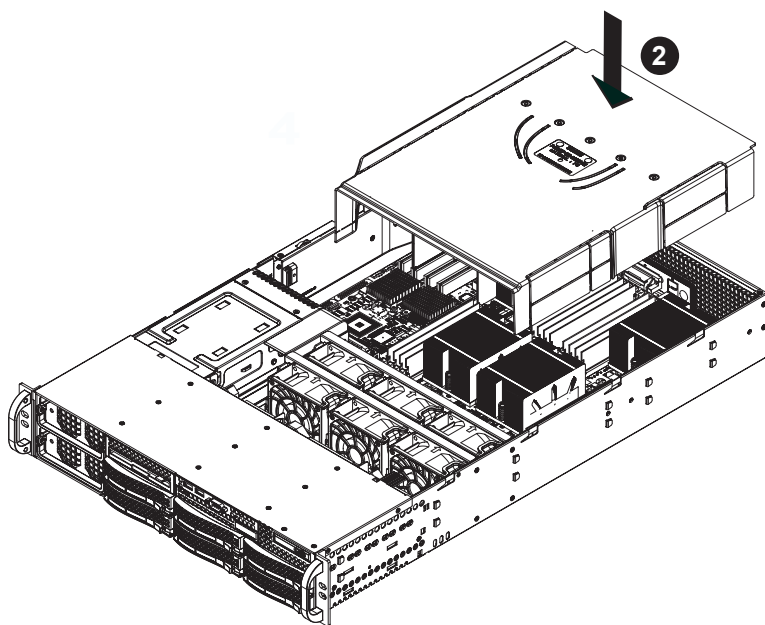

Figure 4-6 Installing the Air Shroud

4-6 Removing the Hard Drive Tray and Installing a Hard Drive

To install a hard disk drive into the chassis, it is necessary to remove the HDD tray from the chassis.

Removing a Hard Drive Tray

1. Press the release tab on the front of each hard drive tray to unlock the HDD tray.
2. Using the handle, pull the HDD tray out from the chassis as shown.

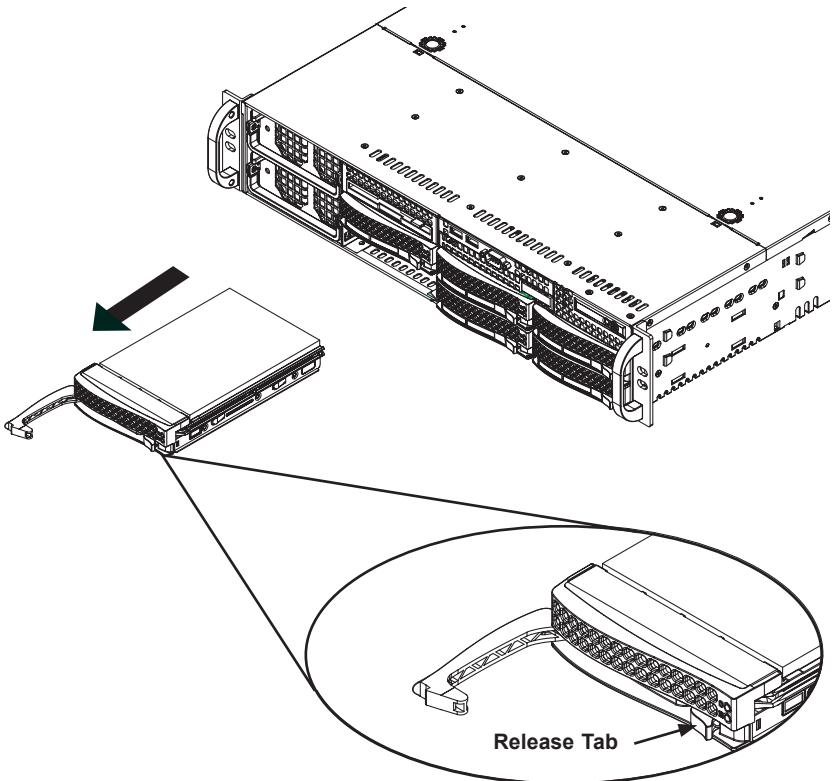

Figure 4-7 Removing a Hard Drive Tray

Replacing a Hard Drive in the Hard Drive Tray

1. Remove the two screws that attach to the both sides of the dummy HDD.
2. Slide out the dummy HDD as shown

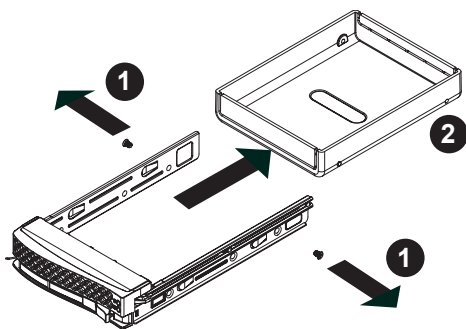

Figure 4-8 Removing the Dummy Hard Drive

3. Slide a hard drive into the HDD tray, and secure the HDD to the tray with two screws on each side of the tray as shown.

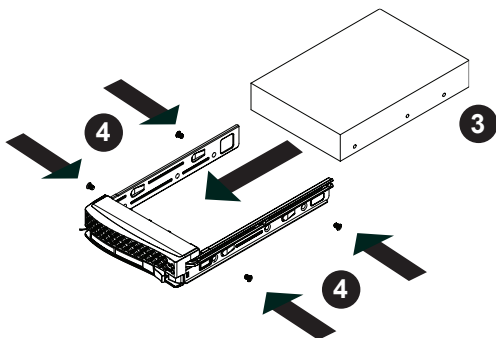

Figure 4-9 Installing the Hard Drive into the Tray

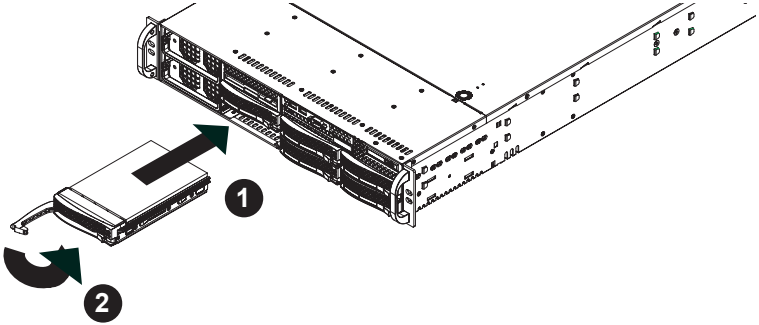

Figure 4-10 Installing the Hard Drive and Tray into the Chassis

Installing a Hard Drive and Hard Drive Tray into the Chassis

1. Insert the hard drive and hard drive tray into the hard drive tray slot in the chassis.
2. Fold the HDD tray's handle inward until it clicks into the locked position.

4-7 Add-on Card/Expansion Slot Setup

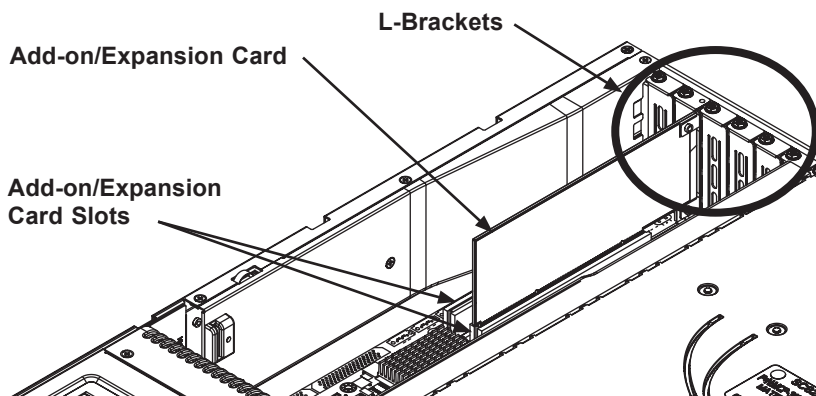

Figure 5-11: Remove the Add-on Card Slot screw

SC828 chassis includes seven slots for add-on cards and expansion cards.

Installing an Add-on or Expansion card:

1. Confirm that each add on card you are installing includes a standard L-bracket.
2. Disconnect the power supply and lay the chassis on a flat surface. If you have not done so, open the chassis cover.
3. Remove the screw holding the slot cover in place for each slot you want to use. Keep this screw for later use.
4. Connect the add-on cards and/or expansion cards to the mother board. Follow add-on card manufacturer's instructions.
5. Secure each card to the chassis using the card's L bracket and the screw previously removed.

Chapter 5

Rack Installation

5-1 Overview

This chapter provides a quick setup checklist to get your chassis up and running. Following these steps in the order given should enable you to have the system operational within a minimum amount of time.

5-2 Unpacking the System

You should inspect the box the chassis was shipped in and note if it was damaged in any way. If the chassis itself shows damage you should file a damage claim with the carrier who delivered it.

Decide on a suitable location for the rack unit that will hold your chassis. It should be situated in a clean, dust-free area that is well ventilated. Avoid areas where heat, electrical noise and electromagnetic fields are generated. You will also need it placed near a grounded power outlet. Be sure to read the Rack and Server Precautions in the next section.

5-3 Preparing for Setup

The box your chassis was shipped in should include two sets of rail assemblies, two rail mounting brackets and the mounting screws you will need to install the system into the rack. Please read this section in its entirety before you begin the installation procedure outlined in the sections that follow.

Choosing a Setup Location

- Leave enough clearance in front of the rack to enable you to open the front door completely (~25 inches).
- Leave approximately 30 inches of clearance in the back of the rack to allow for sufficient airflow and ease in servicing.



Warnings and Precautions!



- This product is for installation only in a Restricted Access Location (dedicated equipment rooms, service closets and the like).

Rack Precautions

- Ensure that the leveling jacks on the bottom of the rack are fully extended to the floor with the full weight of the rack resting on them.
- In single rack installation, stabilizers should be attached to the rack.
- In multiple rack installations, the racks should be coupled together.
- Always make sure the rack is stable before extending a component from the rack.
- You should extend only one component at a time - extending two or more simultaneously may cause the rack to become unstable.

General Server Precautions

- Review the electrical and general safety precautions that came with the components you are adding to your chassis.
- Determine the placement of each component in the rack *before* you install the rails.
- Install the heaviest server components on the bottom of the rack first, and then work up.
- Use a regulating uninterruptible power supply (UPS) to protect the server from power surges, voltage spikes and to keep your system operating in case of a power failure.
- Allow the hot plug hard drives and power supply modules to cool before touching them.

- Always keep the rack's front door and all panels and components on the servers closed when not servicing to maintain proper cooling.

5-4 Rack Mounting Considerations

Ambient Operating Temperature

If installed in a closed or multi-unit rack assembly, the ambient operating temperature of the rack environment may be greater than the ambient temperature of the room. Therefore, consideration should be given to installing the equipment in an environment compatible with the manufacturer's maximum rated ambient temperature (T_{mra}).

Reduced Airflow

Equipment should be mounted into a rack so that the amount of airflow required for safe operation is not compromised.

Mechanical Loading

Equipment should be mounted into a rack so that a hazardous condition does not arise due to uneven mechanical loading.

Circuit Overloading

Consideration should be given to the connection of the equipment to the power supply circuitry and the effect that any possible overloading of circuits might have on overcurrent protection and power supply wiring. Appropriate consideration of equipment nameplate ratings should be used when addressing this concern.

Reliable Ground

A reliable ground must be maintained at all times. To ensure this, the rack itself should be grounded. Particular attention should be given to power supply connections other than the direct connections to the branch circuit (i.e. the use of power strips, etc.).

5-5 Rack Mounting Instructions

This section provides information on installing the SC828 chassis into a rack unit with the rails provided. There are a variety of rack units on the market, which may mean the assembly procedure will differ slightly. You should also refer to the installation instructions that came with the rack unit you are using.

Identifying the Sections of the Rack Rails

The chassis package includes two rack rail assemblies in the rack mounting kit. Each assembly consists of two sections: an inner fixed chassis rail that secures directly to the server chassis and an outer fixed rack rail that secures directly to the rack itself.

Inner Rails

The inner rails come pre-installed on the chassis. The chassis can be used normally with or without a rack. Use the following instruction in the unlikely event you must change the inner rails.

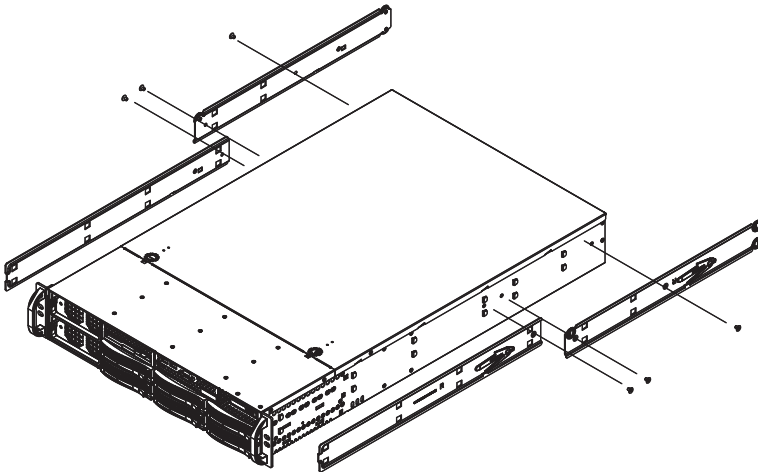

Figure 5-1 Attaching the Inner Rails

Replacing the Inner Rails:

1. Power down and unplug the chassis. It is also recommended that you remove the power plug from the chassis.
2. On a solid, stable surface, lay the chassis on its side.
3. The inner rail is held in place by one screw near the rear of the chassis. Remove this screw.
4. Remove the inner rail by sliding the rail toward the rear of the chassis.
5. Place the new rail on the chassis, aligning the chassis hooks with the rails.
6. Slide the rail toward the front of the chassis.
7. Secure the rail with one screw.
8. Repeat these steps for the other inner rail.

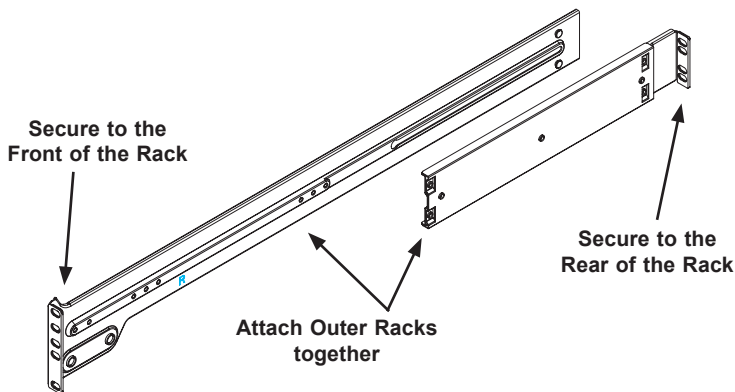

Figure 5-2 Assembling the Outer Rails

Outer Rack Rails

Outer rails attach to the server rack and hold the server in place. The outer rails for the SC828 chassis extend between 26" inches and 33.5" inches. Another set of rails can be ordered that will fit a rack between 19" and 26" deep. To order the second set of rails call or email customer support. The contact information can be found in Chapter One of this manual.

Installing the Outer Rails to the Rack:

1. Attach the short bracket to the outside of the long bracket. You must align the pins with the slides. Also, both bracket ends must face the same direction.
2. Adjust both the short and long brackets to the proper distance so that the rail fits snugly into the rack.
3. Secure the long bracket to the front side of the outer rail with two M5 screws and the short bracket to the rear side of the outer rail with three M5 screws.
4. Repeat steps 1-4 for the left outer rail.

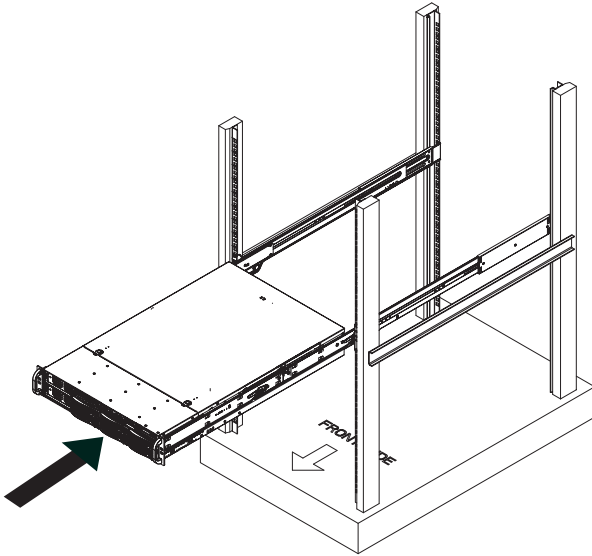

Figure 5-3: Installing the Rack Rails

Installing the Chassis into a Rack:

1. Confirm that chassis includes the inner rails and rail extensions. Also, confirm that the outer rails are installed on the rack.
2. Line chassis rails with the front of the rack rails.
3. Slide the chassis rails into the rack rails, keeping the pressure even on both sides (you may have to depress the locking tabs when inserting). When the server has been pushed completely into the rack, you should hear the locking tabs "click".
4. (Optional) Insert and tightening the thumb screws that hold the front of the server to the rack.

Appendix A

Cables, Screws, and other Accessories

A-1 Overview

This appendix lists supported cables for your chassis system. It only includes the most commonly used components and configurations. For more compatible cables, refer to the manufacturer of the motherboard you are using and our Web site at: www.supermicro.com.

A-2 Cables Included with the SC828 Chassis

SC828TQ-R1200LPB			
Part #	Type	Length	Description
CBL-0044L	Cable	2'	6x SATA cable.
CBL-0157L	Cable	9"	1x 8-pin ribbon cable
CBL-0222L	Cable	65cm / 25.6"	1x 16-pin to 16-pin front control flat cable

SC828TQ-R1000LPB			
Part #	Type	Length	Description
CBL-0044L	Cable	2'	6x SATA cable.
CBL-0157L	Cable	9"	1x 8-pin ribbon cable
CBL-0222L	Cable	65cm / 25.6"	1x 16-pin to 16-pin front control flat cable
CBL-0084	Cable	5.91"	16-pin ribbon front control split converter cable

A-3 Chassis Screws

The accessory box includes all the screws needed to setup your chassis. This section lists and describes the most common screws used. Your chassis may not require all the parts listed.

M/B



Pan head
6-32 x 5 mm
[0.197]

HARD DRIVE



Flat head
6-32 x 5 mm
[0.197]

DVD-ROM, CD-ROM, and FLOPPY DRIVE



Pan head
6-32 x 5 mm
[0.197]



Flat head
6-32 x 5 mm
[0.197]



Round head
M3 x 5 mm
[0.197]



Round head
M2.6 x 5 mm
[0.197]

RAIL



Flat head
M4 x 4 mm
[0.157]



Round head
M4 x 4 mm
[0.157]



Flat head
M5 x 12 mm [0.472]



Washer for M5

M/B STANDOFFS



M/B standoff
6-32 to 6-32



M/B (CPU)
standoff
M5 to 6-32



Thumb screw
6-32 x 5 mm
[0.197]



1/U M/B standoff
6-32 x 5 mm
[0.197]



Appendix B

Power Supply Specifications

This appendix lists power supply specifications for your chassis system.

SC828TQ-R1200LPB	
	1200W
MFR Part #	PWS-IK22-1R
Rated AC Voltage	100 - 240V 50 - 60Hz 6-15Amp
+5V standby	4 Amp
+12V	100 Amp
+5V	30 Amp
+3.3V	25 Amp
-12V	0.6 Amp

SC828TQ-R1000LPB	
	1000W
MFR Part #	PWS-IK01-1R
Rated AC Voltage	100 - 240V 50 - 60Hz 15 - 7Amp
+5V standby	4 Amp
+12V	83 Amp
+5V	30 Amp
+3.3V	20 Amp
-12V	0.6 Amp

Notes

Appendix C

BPN-SAS-828TQ Backplane Specifications

To avoid personal injury and property damage, carefully follow all the safety steps listed below when accessing your system or handling the components.

C-1 ESD Safety Guidelines

Electric Static Discharge (ESD) can damage electronic components. To prevent damage to your system, it is important to handle it very carefully. The following measures are generally sufficient to protect your equipment from ESD.

- Use a grounded wrist strap designed to prevent static discharge.
- Touch a grounded metal object before removing a component from the antistatic bag.
- Handle the RAID card by its edges only; do not touch its components, peripheral chips, memory modules or gold contacts.
- When handling chips or modules, avoid touching their pins.
- Put the card and peripherals back into their antistatic bags when not in use.

C-2 General Safety Guidelines

- Always disconnect power cables before installing or removing any components from the computer, including the backplane.
- Disconnect the power cable before installing or removing any cables from the backplane.
- Make sure that the backplane is securely and properly installed on the motherboard to prevent damage to the system due to power shortage.

C-3 An Important Note to Users

- All images and layouts shown in this user's guide are based upon the latest PCB Revision available at the time of publishing. The card you have received may or may not look exactly the same as the graphics shown in this manual.

Jumper Settings and Pin Definitions

C-4 Front Connectors and Jumpers

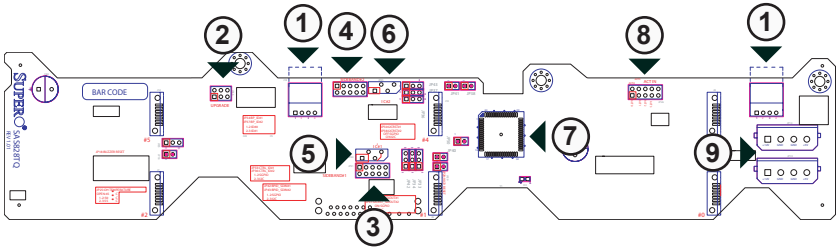

Front Connectors

- | | |
|---|--|
| <ul style="list-style-type: none"> 1. CD-ROM/Floppy Drive Power: JP17 and J18 2. Upgrade Connector JP46 3. SideBand Connector#1 JP51 4. SideBand Connector#2 JP52 5. I²C Connector#1 JP44 6. I²C Connector#2 JP45 7. MG9072 CHIP 8. ACT_IN JP26 | <ul style="list-style-type: none"> 9. Power Connectors (4-pin): JP10 and JP13 10. SAS Port #0 J5 11. SAS Port #1 J6 12. SAS Port #2 J7 13. SAS Port #3 J8 14. SAS Port #4 J10 15. SAS Port #5 J12 |
|---|--|

SAS Ports

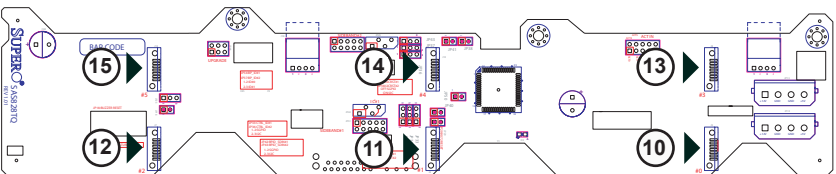

C-5 Front Connector and Pin Definitions

1. CD-ROM/Floppy 4-Pin Connectors

The 4-pin connectors, designated JP105 and JP106, provide power to the CD-ROM and floppy drives. See the table on the right for pin definitions.

CD-ROM/ FDD Power 4-Pin Connector (JP17 and JP18)	
Pin#	Definition
1	+5V
2 and 3	Ground
4	+12V

2. Upgrade Connector

The Upgrade connector, designated JP46, is used for manufacturer's diagnostic purposes only.

3 and 4. Sideband Headers

The sideband headers are designated JP51 and JP52. For SES-2 to work properly, you must connect an 8-pin sideband cable. See the table to the right for pin definitions.

Sideband Headers (JP51 and JP52)			
Pin #	Definition	Pin #	Definition
2	SGPIO: SDIN I²C: Backplane Addressing (SB5)	1	Controller ID (SB6)
4	SGPIO: SDOUT I²C: Reset (SB4)	3	GND (SB2)
6	GND (SB3)	5	SGPIO: SLOAD I²C: SDA (SB1)
8	Backplane ID (SB7)	7	SGPIO: SCLOCK I²C: SCL (SB0)
10	No Connec- tion	9	No Connection

5 and 6. I²C Connectors

The I²C Connectors, designated JP44 and JP45, are used to monitor HDD activity and status. See the table on the right for pin definitions.

I ² C Connector Pin Definitions (JP44 and JP45)	
Pin#	Definition
1	Data
2	Ground
3	Clock
4	No Connection

7. MG9072 Chip

The MG9072 is an enclosure management chip that supports the SES-2 controller and SES-2 protocols.

8. Activity LED Header

The activity LED header, designated JP26, is used to indicate the activity status of each SAS drive. The Activity LED Header is located on the front panel. For the Activity LED Header to work properly, connect using a 10-pin LED cable.

SAS Activity LED Header Pin Definitions (JP26)			
Pin #	Definition	Pin #	Definition
1	ACT IN#0	6	ACT IN#4
2	ACT IN#1	7	ACT IN#5
3	ACT IN#2	8	Not Used
4	ACT IN#3	9	Not Used
5	Ground	10	Empty

9. Backplane Main Power Connectors

The 4-pin connectors, designated JP10, and JP13, provide power to the backplane. See the table on the right for pin definitions.

Backplane Main Power 4-Pin Connector (JP10 and JP13)	
Pin#	Definition
1	+12V
2 and 3	Ground
4	+5V

10-15. SAS Ports

The SAS ports are used to connect the SAS drive cables. The six ports are designated #0 - #5. Each port is also compatible with SAS and SATA drives.

C-6 Front Jumper Locations and Pin Definitions

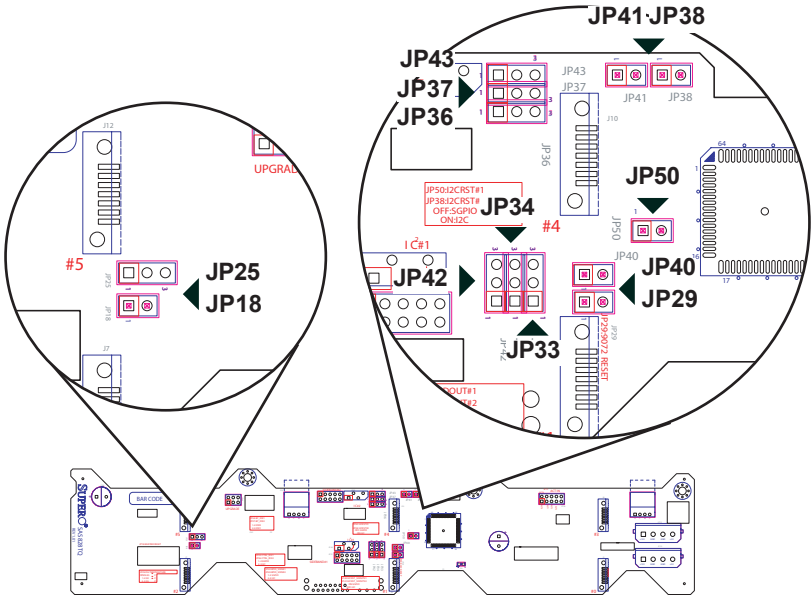

Explanation of Jumpers

To modify the operation of the backplane, jumpers can be used to choose between optional settings. Jumpers create shorts between two pins to change the function of the connector. Pin 1 is identified with a square solder pad on the printed circuit board. Note: On two pin jumpers, "Closed" means the jumper is on and "Open" means the jumper is off the pins.

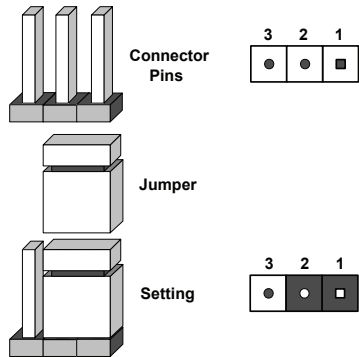

Jumper Settings		
Jumper	Jumper Settings	Note
JP18	Open: Enabled Closed: Disabled	Buzzer Reset
JP25	Open: 45°C 1-2: 50°C 2-3: 55°C	Overheat Temperature
JP29	Open: Default Closed: Reset	MG 9071 Chip Reset

I²C and SGPIO Modes and Jumper Settings

This backplane can utilize I²C or SGPIO. SGPIO is the default mode and can be used without making changes to your jumpers. The following information details which jumpers must be configured to use I²C mode or restore your backplane to SGPIO mode.

SGPIO Setting (Default)		
Jumper	Jumper Setting	Note
JP33	1-2	Controller ID #1
JP34	1-2	Backplane ID #1 (use ID #0)
JP36	1-2	Controller ID #2
JP37	1-2	Backplane ID #2 (use ID #0)
JP38	Open	I ² C Reset #2
JP40	Closed	SDOUT #1
JP41	Closed	SDOUT #2
JP42	1-2	SDIN #1
JP43	1-2	SDIN #2
JP50	Open	I ² C Reset #1

I²C Setting		
Jumper	Jumper Setting	Note
JP33	2-3	Controller ID #1
JP34	1-2	Backplane ID #1 (use ID #0)
JP36	2-3	Controller ID #2
JP37	2-3	Backplane ID #2 (use ID #1)
JP38	Closed	I ² C Reset #2
JP40	Open	I ² C Reset #1
JP41	Open	I ² C Reset #2
JP42	2-3	Backplane ID #1
JP43	2-3	Backplane ID #2
JP50	Closed	I ² C Reset #1

C-7 Rear Connectors and LED Indicators

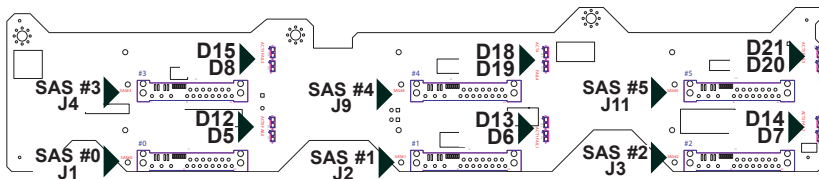

Rear SAS/SATA Connectors

Rear Connector	SAS Drive Number
SAS #0	SAS/SATA HDD #0
SAS #1	SAS/SATA HDD #1
SAS #2	SAS/SATA HDD #2
SAS #3	SAS/SATA HDD #3
SAS #4	SAS/SATA HDD #4
SAS #5	SAS/SATA HDD #5

Rear LED Indicators

Rear LED	Hard Drive Activity	Failure LED
SAS #0	D12	D5
SAS #1	D13	D6
SAS #2	D14	D7
SAS #3	D15	D8
SAS #4	D18	D19
SAS #5	D21	D20