

SUPERO[®]

SC837J CHASSIS SERIES

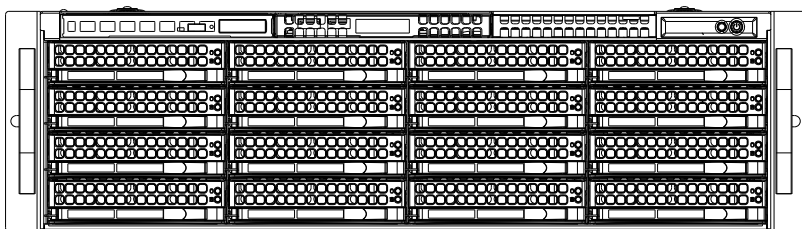

SC837E16-RJBOD1

SC837E26-RJBOD1

USER'S MANUAL

1.0b

The information in this User's Manual has been carefully reviewed and is believed to be accurate. The vendor assumes no responsibility for any inaccuracies that may be contained in this document, makes no commitment to update or to keep current the information in this manual, or to notify any person or organization of the updates. **Please Note: For the most up-to-date version of this manual, please see our web site at www.supermicro.com.**

Super Micro Computer, Inc. ("Supermicro") reserves the right to make changes to the product described in this manual at any time and without notice. This product, including software and documentation, is the property of Supermicro and/or its licensors, and is supplied only under a license. Any use or reproduction of this product is not allowed, except as expressly permitted by the terms of said license.

IN NO EVENT WILL SUPERMICRO BE LIABLE FOR DIRECT, INDIRECT, SPECIAL, INCIDENTAL, SPECULATIVE OR CONSEQUENTIAL DAMAGES ARISING FROM THE USE OR INABILITY TO USE THIS PRODUCT OR DOCUMENTATION, EVEN IF ADVISED OF THE POSSIBILITY OF SUCH DAMAGES. IN PARTICULAR, SUPERMICRO SHALL NOT HAVE LIABILITY FOR ANY HARDWARE, SOFTWARE, OR DATA STORED OR USED WITH THE PRODUCT, INCLUDING THE COSTS OF REPAIRING, REPLACING, INTEGRATING, INSTALLING OR RECOVERING SUCH HARDWARE, SOFTWARE, OR DATA.

Any disputes arising between manufacturer and customer shall be governed by the laws of Santa Clara County in the State of California, USA. The State of California, County of Santa Clara shall be the exclusive venue for the resolution of any such disputes. Super Micro's total liability for all claims will not exceed the price paid for the hardware product.

California Best Management Practices Regulations for Perchlorate Materials: This Perchlorate warning applies only to products containing CR (Manganese Dioxide) Lithium coin cells. "Perchlorate Material-special handling may apply. See www.dtsc.ca.gov/hazardouswaste/perchlorate"

WARNING: Handling of lead solder materials used in this product may expose you to lead, a chemical known to the State of California to cause birth defects and other reproductive harm.

Manual Revision 1.0b
Release Date: October 28, 2011

Unless you request and receive written permission from Super Micro Computer, Inc., you may not copy any part of this document.

Information in this document is subject to change without notice. Other products and companies referred to herein are trademarks or registered trademarks of their respective companies or mark holders.

Copyright © 2011 by Super Micro Computer, Inc.
All rights reserved.

Printed in the United States of America

Contacting Supermicro

Headquarters

Address: Super Micro Computer, Inc.
980 Rock Ave.
San Jose, CA 95131 U.S.A.

Tel: +1 (408) 503-8000

Fax: +1 (408) 503-8008

Email: marketing@supermicro.com (General Information)
support@supermicro.com (Technical Support)

Web Site: www.supermicro.com

Europe

Address: Super Micro Computer B.V.
Het Sterrenbeeld 28, 5215 ML
's-Hertogenbosch, The Netherlands

Tel: +31 (0) 73-6400390

Fax: +31 (0) 73-6416525

Email: sales@supermicro.nl (General Information)
support@supermicro.nl (Technical Support)
rma@supermicro.nl (Customer Support)

Asia-Pacific

Address: Super Micro Computer, Inc.
4F, No. 232-1, Liancheng Rd.
Chung-Ho 235, Taipei County
Taiwan, R.O.C.

Tel: +886-(2) 8226-3990

Fax: +886-(2) 8226-3991

Web Site: www.supermicro.com.tw

Technical Support:

Email: support@supermicro.com.tw

Tel: +886-(2) 8226-5990

Preface

About This Manual

This manual is written for professional system integrators and PC technicians. It provides information for the installation and use of the SC837J chassis. Installation and maintenance should be performed by experienced technicians only.

This manual lists compatible parts available when this document was published. Always refer to the our Web site for updates on supported parts and configurations.

Manual Organization

Chapter 1: Introduction

The first chapter provides a checklist of the main components included with this chassis and describes the main features of the SC837J chassis. This chapter also includes contact information.

Chapter 2: System Safety

This chapter lists warnings, precautions, and system safety. It is recommended that you thoroughly familiarize yourself with installing and servicing the chassis and all safety precautions.

Chapter 3: System Interface

Refer to this chapter for details on the system interface, which includes the functions and information provided by the chassis control panel, as well as other LEDs located throughout the system.

Chapter 4: Chassis Setup and Maintenance

Follow the procedures given in this chapter when installing, removing, or reconfiguring components in your chassis.

Chapter 5: Rack Installation

Refer to this chapter for detailed information on chassis rack installation. You should follow the procedures given in this chapter when installing, removing or reconfiguring your chassis into a rack environment.

The following appendices list compatible cables, power supply specifications, and backplanes. Not all compatible backplanes are listed. Refer to our Web site for the latest compatible backplane information.

Appendix A: Cables and Hardware

This section provides information on cabling, and other hardware which is compatible with your chassis. For complete information on supported cables and hardware, refer to the Supermicro Web site at www.supermicro.com.

Appendix B: Power Supply Specifications

This chapter lists specifications for the power supply provided with your chassis. For additional information, refer to the Supermicro website at www.supermicro.com.

Appendix C: SAS2-837EL Backplane Specifications

This section contains detailed information on the SAS2-837EL1 and SAS2-837EL2 backplanes. Additional details can be found on the Supermicro Web site at www.supermicro.com.

Appendix D: SAS-837A Backplane Specifications

This section lists detailed specifications on the SAS-837A backplane. Additional information can be found on the Supermicro Web site at www.supermicro.com.

Table of Contents

Contacting Supermicro	iii
Chapter 1 Introduction	
1-1 Overview	1-1
1-2 Shipping List	1-1
1-3 Where to get Replacement Components	1-2
1-4 Returning Merchandise for Service	1-3
Chapter 2 System Safety	
2-1 Overview	2-1
2-2 Warnings and Precautions	2-1
2-3 Preparing for Setup	2-1
2-4 Electrical Safety Precautions	2-2
2-5 General Safety Precautions	2-3
2-6 System Safety	2-3
Chapter 3 System Interface	
3-1 Overview	3-1
3-2 Control Panel Buttons	3-2
3-3 Control Panel LEDs	3-2
3-4 Drive Carrier LEDs	3-4
SAS/SATA Drives	3-4
SCSI Drives	3-4
Chapter 4 Chassis Setup and Maintenance	
4-1 Overview	4-1
4-2 Removing the Chassis Cover	4-2
4-3 Installing Removable Hard Drives	4-3
4-6 System Fans	4-6
4-7 Power Supply	4-8
Chapter 5 Rack Installation	
5-1 Overview	5-1
5-2 Unpacking the System	5-1
5-3 Preparing for Setup	5-1
Choosing a Setup Location	5-1
Rack Precautions	5-2
General Server Precautions	5-2
Rack Mounting Considerations	5-3
Ambient Operating Temperature	5-3

	Reduced Airflow	5-3
	Mechanical Loading	5-3
	Circuit Overloading.....	5-3
	Reliable Ground	5-3
	Installing the Inner Rails	5-4
5-4	Rack Mounting Instructions.....	5-4
	Installing the Outer Rails on the Rack.....	5-5
	Installing the Chassis into a Rack.....	5-6

Appendix A SC837J Cables and Hardware

Appendix B SC837J Power Supply Specifications

Appendix C SAS2-837EL Backplane Specifications

Appendix D SAS-837A Backplane Specifications

Chapter 1

Introduction

1-1 Overview

Optimized for enterprise-level heavy-capacity storage applications, Supermicro's SC837 JBOD chassis features up to twenty-eight (sixteen front plus twelve rear) 3.5" hot-swap HDD bays.

The SC837J design provides high-density storage in a 3U form factor, with high power efficiency, optimized HDD signal trace routing and improved HDD carrier design to dampen vibration and maximize performance. Equipped with redundant 1620W (Platinum Level) high-efficiency redundant power supplies with PMBus functionality and I²C for enhanced power management and and five hot-plug redundant cooling fans, the SC837J is a reliable storage system.

1-2 Shipping List

Please visit the Supermicro Web site for the latest shipping lists and part numbers for your particular chassis model <http://www.supermicro.com/>

SC837J Chassis		
Model	HDD	Power Supply
SC837E16-RJBOD1	28x (JBOD) SAS/SATA	1620W redundant (Gold Level)
SC837E26-RJBOD1	28x (JBOD) SAS/SATA	1620W redundant (Gold Level)

1-3 Where to get Replacement Components

Though not frequently, you may need replacement parts for your system. To ensure the highest level of professional service and technical support, we strongly recommend purchasing exclusively from our Supermicro Authorized Distributors/System Integrators/Resellers. A list of Supermicro Authorized Distributors/System Integrators/Resellers can be found at: <http://www.supermicro.com>. Click the Where to Buy link.

1-4 Returning Merchandise for Service

A receipt or copy of your invoice marked with the date of purchase is required before any warranty service will be rendered. You can obtain service by calling your vendor for a Returned Merchandise Authorization (RMA) number. When returning to the manufacturer, the RMA number should be prominently displayed on the outside of the shipping carton, and mailed prepaid or hand-carried. Shipping and handling charges will be applied for all orders that must be mailed when service is complete.

For faster service, RMA authorizations may be requested online (<http://www.supermicro.com/support/rma/>).

Whenever possible, repack the chassis in the original Supermicro carton, using the original packaging material. If these are no longer available, be sure to pack the chassis securely, using packaging material to surround the chassis so that it does not shift within the carton and become damaged during shipping.

This warranty only covers normal consumer use and does not cover damages incurred in shipping or from failure due to the alteration, misuse, abuse or improper maintenance of products.

During the warranty period, contact your distributor first for any product problems.

Notes

Chapter 2

System Safety

2-1 Overview

This chapter provides a quick setup to get your chassis up and running. Following the steps in the order given should enable you to have your chassis set up and operational within a minimal amount of time. This quick setup assumes that you are an experienced technician, familiar with common concepts and terminology.

2-2 Warnings and Precautions

You should inspect the box the chassis was shipped in and note if it was damaged in any way. If the chassis itself shows damage, file a damage claim with carrier who delivered your system.

Decide on a suitable location for the rack unit that will hold that chassis. It should be situated in a clean, dust-free area that is well ventilated. Avoid areas where heat, electrical noise and eletromagnetic fields are generated.

The system must be placed near at two grounded power outlets. When configured, the SC837J chassis includes one primary and one redundant power supply.

2-3 Preparing for Setup

The SC837J chassis includes a set of rail assemblies which includes mounting brackets and mounting screws you will need to install the systems into the rack. Please read this manual in its entirety before you begin the installation procedure.

2-4 Electrical Safety Precautions

Basic electrical safety precautions should be followed to protect yourself from harm and the SC837J from damage:

- Be aware of the locations of the power on/off switch on the chassis as well as the room's emergency power-off switch, disconnection switch or electrical outlet. If an electrical accident occurs, you can then quickly remove power from the system.
- Do not work alone when working with high-voltage components.
- Power should always be disconnected from the system when removing or installing main system components, such as the serverboard and memory modules (not necessary for hot swappable drives). When disconnecting power, you should first power-down the system with the operating system and then unplug the power cords from all the power supply modules in the system.
- When working around exposed electrical circuits, another person who is familiar with the power-off controls should be nearby to switch off the power if necessary.
- Use only one hand when working with powered-on electrical equipment. This is to avoid making a complete circuit, which will cause electrical shock. Use extreme caution when using metal tools, which can easily damage any electrical components or circuit boards they come into contact with.
- Do not use mats designed to decrease electrostatic discharge as protection from electrical shock. Instead, use rubber mats that have been specifically designed as electrical insulators.
- The power supply power cord must include a grounding plug and must be plugged into a grounded electrical outlet.
- Serverboard battery: CAUTION - There is a danger of explosion if the onboard battery is installed upside down, which will reverse its polarities This battery must be replaced only with the same or an equivalent type recommended by the manufacturer. Dispose of used batteries according to the manufacturer's instructions.

- Handle used batteries carefully. Do not damage the battery in any way; a damaged battery may release hazardous materials into the environment. Do not discard a used battery in the garbage or a public landfill. Please comply with the regulations set up by your local hazardous waste management agency to dispose of your used battery properly.

2-5 General Safety Precautions

- Keep the area around the chassis clean and free of clutter.
- Place the chassis top cover and any system components that have been removed away from the system or on a table so that they won't accidentally be stepped on.
- While working on the system, do not wear loose clothing such as neckties and unbuttoned shirt sleeves, which can come into contact with electrical circuits or be pulled into a cooling fan.
- Remove any jewelry or metal objects from your body, which are excellent metal conductors that can create short circuits and harm you if they come into contact with printed circuit boards or areas where power is present.
- After accessing the inside of the system, close the system back up and secure it to the rack unit with the retention screws after ensuring that all connections have been made.

2-6 System Safety

Electrostatic discharge (ESD) is generated by two objects with different electrical charges coming into contact with each other. An electrical discharge is created to neutralize this difference, which can damage electronic components and printed circuit boards. The following measures are generally sufficient to neutralize this difference before contact is made to protect your equipment from ESD:

- Do not use mats designed to decrease electrostatic discharge as protection from electrical shock. Instead, use rubber mats that have been specifically designed as electrical insulators.
- Use a grounded wrist strap designed to prevent static discharge.
- Keep all components and printed circuit boards (PCBs) in their antistatic bags until ready for use.

- Touch a grounded metal object before removing any board from its antistatic bag.
- Do not let components or PCBs come into contact with your clothing, which may retain a charge even if you are wearing a wrist strap.
- Handle a board by its edges only; do not touch its components, peripheral chips, memory modules or contacts.
- When handling chips or modules, avoid touching their pins.
- Put the serverboard and peripherals back into their antistatic bags when not in use.
- For grounding purposes, make sure your computer chassis provides excellent conductivity between the power supply, the case, the mounting fasteners and the serverboard.

Chapter 3

System Interface

3-1 Overview

There are several LEDs on the control panel as well as others on the drive carriers to keep you constantly informed of the overall status of the system as well as the activity and health of specific components. SC837J models have two buttons on the chassis control panel: A reset button and a power on/off switch. This chapter explains the meanings of all LED indicators and the appropriate responses you may need to take.

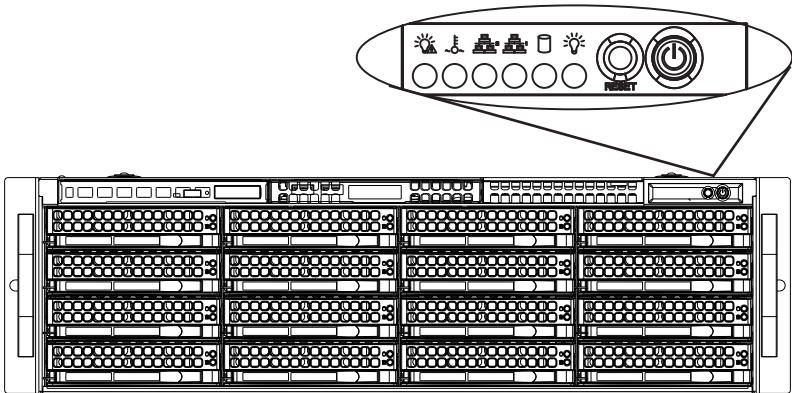

Figure 3-1: Control Panel

3-2 Control Panel Buttons

There are two push-buttons located on the left handle of the chassis. These are (in order from top to bottom) a power on/off button and a reset button.



Power: The main power button is used to apply or remove power from the power supply to the server system. Turning off system power with this button removes the main power but keeps standby power supplied to the system. Therefore, you must unplug system before servicing.

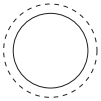

Reset: The reset button is used to reboot the system.

3-3 Control Panel LEDs

The control panel located on the left handle of the SC837J chassis has five LEDs. These LEDs provide you with critical information related to different parts of the system. This section explains what each LED indicates when illuminated and any corrective action you may need to take.



Power Failure: When this LED flashes, it indicates a failure in the redundant power supply.



Overheat/Fan Fail: When this LED flashes, it indicates a fan failure. When continuously on (not flashing) it indicates an overheat condition, which may be caused by cables obstructing the airflow in the system or the ambient room temperature being too warm. Check the routing of the cables and make sure all fans are present and operating normally. You should also check to make sure that the chassis covers are installed. Finally, verify that the heatsinks are installed properly. This LED will remain flashing or on as long as the overheat condition exists.



NIC1: Indicates network activity on GLAN1 when flashing.



NIC2: Indicates network activity on GLAN2 when flashing.



HDD: Indicates IDE channel activity. SAS/SATA drive, and/or DVD-ROM drive activity when flashing.



Power: Indicates power is being supplied to the system's power supply units. This LED should normally be illuminated when the system is operating.

3-4 Drive Carrier LEDs

Your chassis uses SAS/SATA.

SAS/SATA Drives

Each SAS/SATA drive carrier has two LEDs.

- **Blue:**

Solid on = Drive is present and available.

Blinking = Drive is actively being accessed.

Each Serial ATA drive carrier has a blue LED. When illuminated in a solid on state, this blue LED (on the front of the SAS/SATA drive carrier) indicates drive activity. A connection to the SAS/SATA backplane enables this LED to blink on and off when that particular drive is being accessed.

- **Red:**

Solid on = Drive failure

Blinking = RAID activity

When the red LED is blinking, it indicates that the system is either building, initializing or rebuilding RAID.

SCSI Drives

This chassis does not support SCSI drives at this time.

Chapter 4

Chassis Setup and Maintenance

4-1 Overview

This chapter covers the steps required to install components and perform maintenance on the chassis. The only tool you will need to install components and perform maintenance is a Phillips screwdriver. Print this chapter to use as a reference while setting up your chassis.



Review the warnings and precautions listed in the manual before setting up or servicing this chassis. These include information in Chapter 2: System Safety and the warnings/precautions listed in the setup instructions.



Safety Warning: Before performing any chassis setup or maintenance, it is recommended that the chassis be removed from the rack and placed on a stable bench or table. For instructions on how to uninstall the chassis from the rack, refer to Chapter 5 Rack Installation in this manual.

4-2 Removing the Chassis Cover

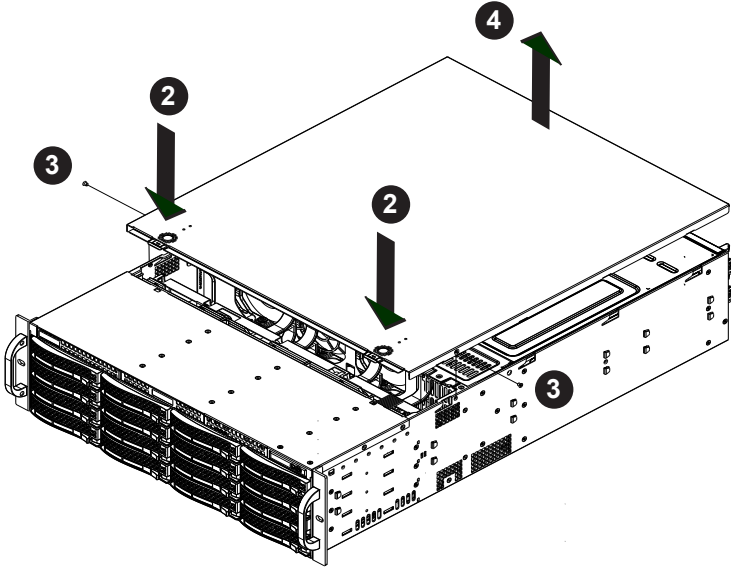

Figure 4-1: Removing the Chassis Cover

Removing the Chassis Cover

1. Unplug the chassis from any power source.
2. Push down on both release buttons simultaneously.
3. Remove the screws securing the cover to the chassis.
4. Lift the cover up and off the chassis.



Warning: Except for short periods of time, do NOT operate the server without the cover in place. The chassis cover must be in place to allow proper airflow and prevent overheating.

4-3 Installing Removable Hard Drives

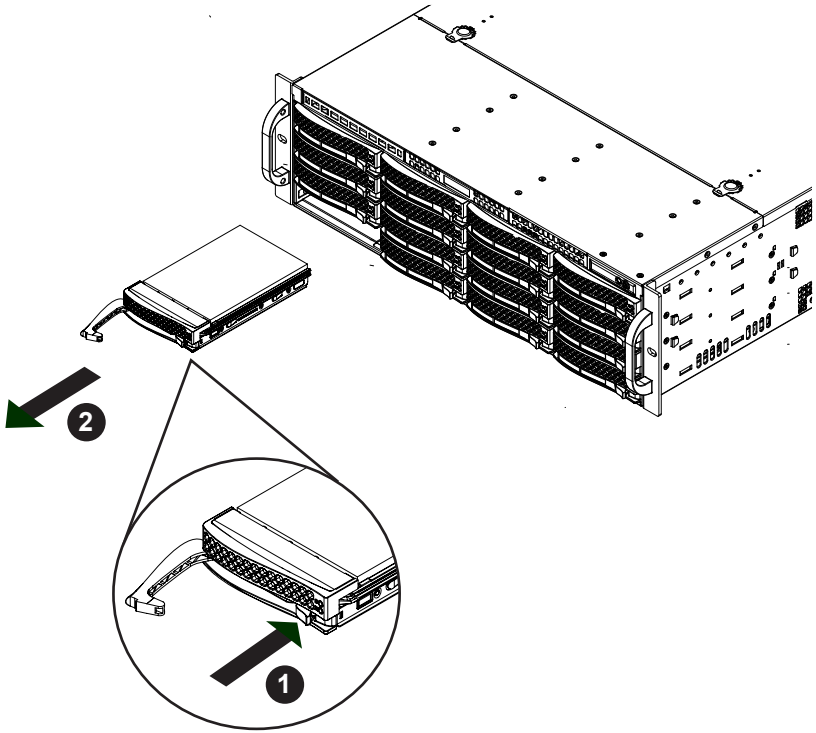

Figure 4-2: Removing a Hard Drive Carrier

Removing Hard Drive Carriers from the Chassis

1. Press the release button on the drive carrier. This extends the drive carrier handle.
2. Use the handle to pull the drive carrier out of the chassis.

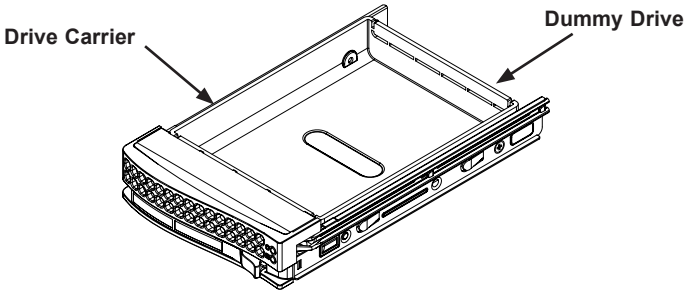

Figure 4-3: Chassis Drive Carrier

The drives are mounted in drive carriers to simplify their installation and removal from the chassis. These carriers also help to promote proper airflow for the drive bays.



Warning: Except for short periods of time (while swapping hard drives) do not operate the server with the drives removed from the chassis drive bays.

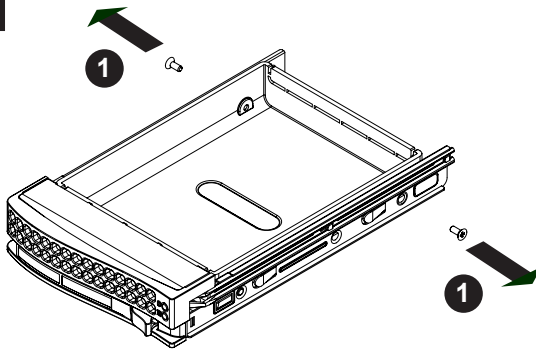

Figure 4-4: Removing the Dummy Drive from the Carrier



Warning! Enterprise level hard disk drives are recommended for use in Supermicro chassis and servers. For information on recommended HDDs, visit the Supermicro Web site at <http://www.supermicro.com/products/info/storage.cfm>

Installing a Hard Drive to the Hard Drive Carrier

1. Remove the two screws securing the dummy drive to the drive carrier and remove the dummy drive. Place the hard drive carrier on a flat surface such as a desk, table or work bench.

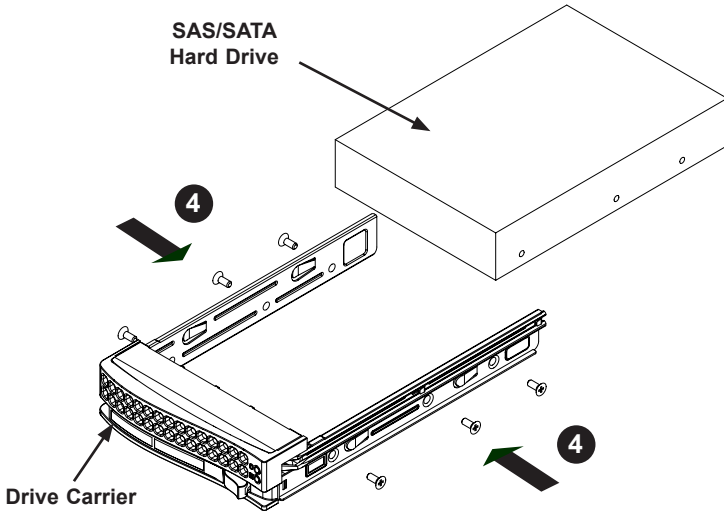

Figure 4-5: Installing the Hard Drive into the Carrier

2. Slide the hard drive into the carrier with the printed circuit board side facing down.
3. Carefully align the mounting holes in both the drive carrier and the hard drive.
4. Secure the hard drive to the carrier using six screws.
5. Return the drive carrier to the chassis bay. Make sure to close the drive carrier handle to lock the drive carrier into place.

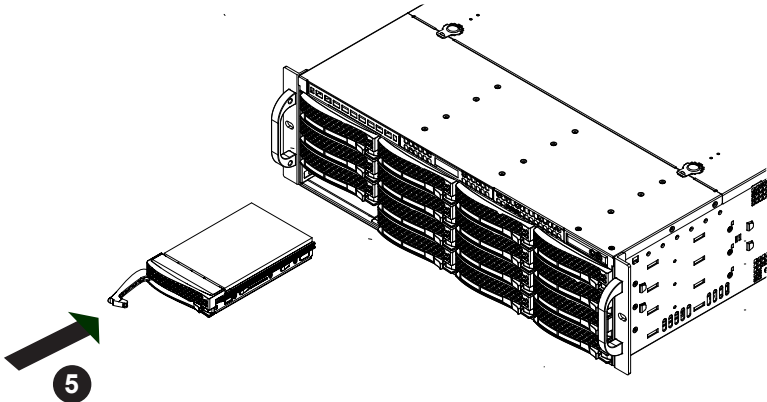

Figure 4-6: Installing the Hard Drive

4-6 System Fans

Seven hot-swappable, heavy-duty fans provide cooling for the chassis. These fans circulate air through the chassis, thereby lowering the chassis internal temperature.

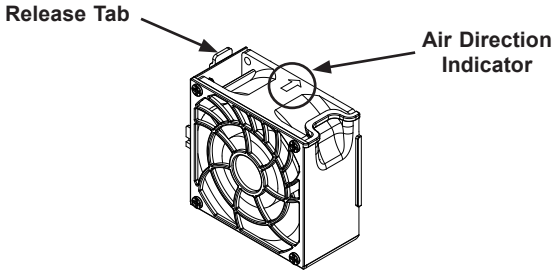

Figure 4-7: System Fan

Replacing a System Fan

1. Open the chassis while the system is running to determine which fan has failed. (Never run the server for an extended period of time with the chassis cover open.)
2. Remove the failed fan's power cord from the serverboard.
3. Press the fan release tab to lift the failed fan from the chassis and pull it completely out of the chassis.
4. Place the new fan into the vacant space in the housing while making sure the arrows on the top of the fan (indicating air direction) point in the same direction as the arrows on the other fans.
5. Check that the fan is working properly before replacing the chassis cover.

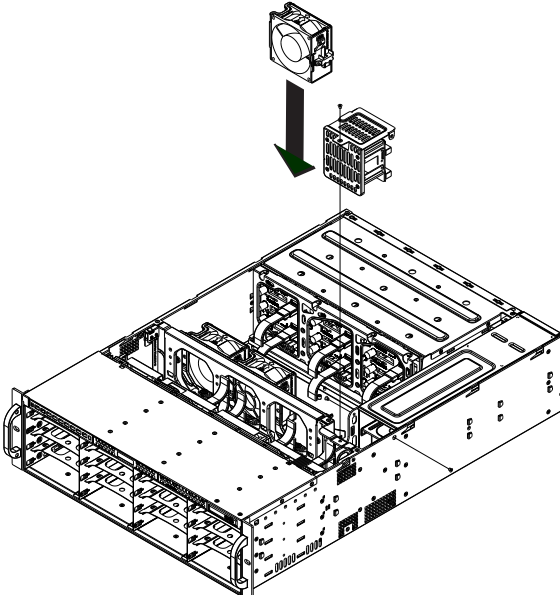

Figure 4-8: Placing the System Fan

4-7 Power Supply

The SC837J chassis has a 1620 Watt high-efficiency redundant power supply. This power supply is auto-switching capable. This enables it to automatically sense and operate at a 100v to 240v input voltage. An amber light will be illuminated on the power supply when the power is off. An illuminated green light indicates that the power supply is operating.

Redundant power supplies are hot-swappable, and can be changed without powering down the system. New units can be ordered directly from Supermicro (see contact information in the Preface).

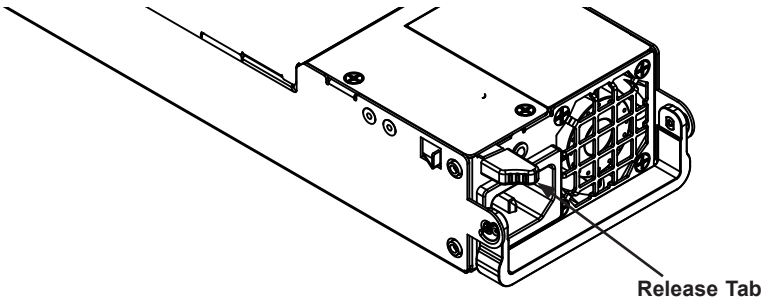

Figure 4-9: Power Supply Release Tab

Changing the Power Supply:

1. If your chassis includes a redundant power supply (at least two power modules), you can leave the server running and remove only one power supply. If your server has only one power supply, you must power down the server and unplug the power cord.
2. Push the release tab (on the back of the power supply) as illustrated.
3. Pull the power supply out using the handle provided.

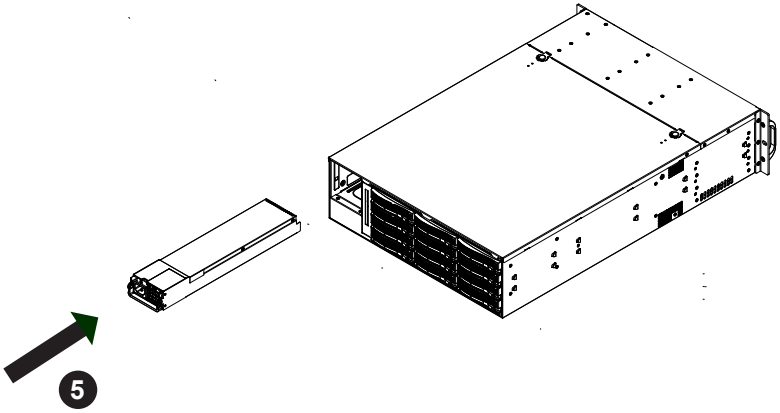

Figure 4-10: Power Supply Release Tab

4. Replace the failed power module with the same model.
5. Push the new power supply module into the power bay until you hear a click.
6. If using only one power supply, plug the AC power cord back into the module and power up the server.

Notes

Chapter 5

Rack Installation

5-1 Overview

This chapter provides a quick setup for installing the chassis into a rack. Following these steps in the order given should enable you to have the system installed within a minimum amount of time.

5-2 Unpacking the System

You should inspect the box the chassis was shipped in and note if it was damaged in any way. If the chassis itself shows damage you should file a damage claim with the carrier who delivered it.

Decide on a suitable location for the rack unit that will hold your chassis. It should be situated in a clean, dust-free area that is well ventilated. Avoid areas where heat, electrical noise and electromagnetic fields are generated. You will also need to position the rack near a grounded power outlet. Be sure to read the Rack Precautions and General Server Precautions in the next section.

5-3 Preparing for Setup

The box your chassis was shipped in includes a set of rail assemblies (two inner rails and two outer rails), and the mounting screws you will need to install the system into the rack. Please read this section in its entirety before you begin the installation procedure outlined in the sections that follow.

Choosing a Setup Location

- Leave enough clearance in front of the rack to enable you to open the front door completely (~25 inches).
- Leave approximately 30 inches of clearance in the back of the rack to allow for sufficient airflow and ease in servicing.



Warnings and Precautions!



- This product is for installation only in a Restricted Access Location (dedicated equipment rooms, service closets and the like).

Rack Precautions

- Ensure that the leveling jacks on the bottom of the rack are fully extended to the floor with the full weight of the rack resting on them.
- In single rack installation, stabilizers should be attached to the rack.
- In multiple rack installations, the racks should be coupled together.
- Always make sure the rack is stable before extending a component from the rack.
- You should extend only one component at a time - extending two or more simultaneously may cause the rack to become unstable.

General Server Precautions

- Review the electrical and general safety precautions that came with the components you are adding to your chassis.
- Determine the placement of each component in the rack *before* you install the rails.
- Install the heaviest server components on the bottom of the rack first, and then work up.
- Use a regulating uninterruptible power supply (UPS) to protect the server from power surges, voltage spikes and to keep your system operating in case of a power failure.
- Allow the hot-plug hard drives and power supply modules to cool before touching them.

Rack Mounting Considerations

Ambient Operating Temperature

If installed in a closed or multi-unit rack assembly, the ambient operating temperature of the rack environment may be greater than the ambient temperature of the room. Therefore, consideration should be given to installing the equipment in an environment compatible with the manufacturer's maximum rated ambient temperature.

Reduced Airflow

Equipment should be mounted into a rack so that the amount of airflow required for safe operation is not compromised.

Mechanical Loading

Equipment should be mounted into a rack so that a hazardous condition does not arise due to uneven mechanical loading.

Circuit Overloading

Consideration should be given to the connection of the equipment to the power supply circuitry and the effect that any possible overloading of circuits might have on overcurrent protection and power supply wiring. Appropriate consideration of equipment nameplate ratings should be used when addressing this concern.

Reliable Ground

A reliable ground must be maintained at all times. To ensure this, the rack itself should be grounded. Particular attention should be given to power supply connections other than the direct connections to the branch circuit (for example, the use of power strips, etc.).

5-4 Rack Mounting Instructions

This section provides information on installing the SC837J chassis into a rack unit with the rails provided. There are a variety of rack units on the market, which may mean the assembly procedure may differ slightly. You should also refer to the installation instructions that came with the rack unit you are using.

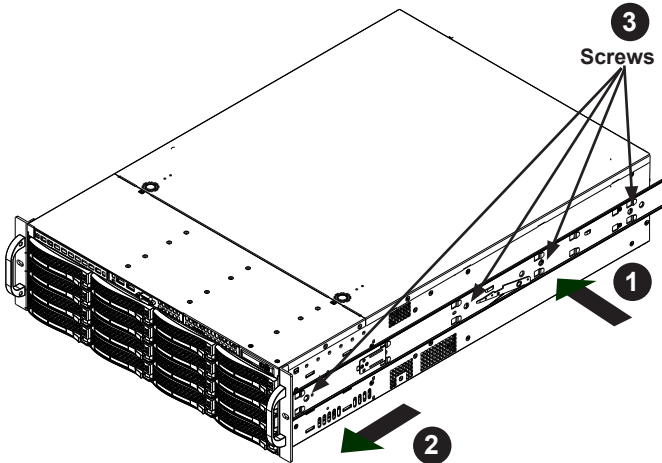

Figure 7-2: Installing the Inner Rails

Installing the Inner Rails

Inner Rail Installation

1. Place the inner rail on the side of the chassis aligning the hooks of the chassis with the holes in the inner rail.
2. Slide the inner rail toward the front of the chassis.
3. Secure the chassis with four screws as illustrated.
4. Repeat steps 1-3 for the other inner rail.

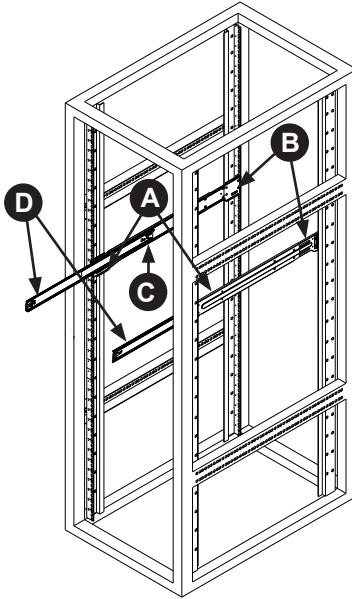

Figure 7-3: Installing the Outer Rails

Installing the Outer Rails on the Rack

Outer rails attach to the server rack and hold the chassis in place. The outer rails for the SC837J chassis extend between thirty inches and thirty-three inches.

Installing the Outer Rails

1. Begin by measuring the distance from the front to the back of the rack.
2. Slide the shorter outer rail (A) into the longer outer rail (B).
3. Attach the front of the shorter outer rail (A) to the front of the rack and the back of the longer outer rail (B) to the rear of the rack.
4. Adjust both the shorter and longer outer rails to the proper distance so that they fit snugly into the rack and secure with the screws provided.
5. Press the release tab (C) on the inside of the outer rail to release the outer rail extension (D)
6. Repeat steps 1 through 5 for the remaining outer rail.

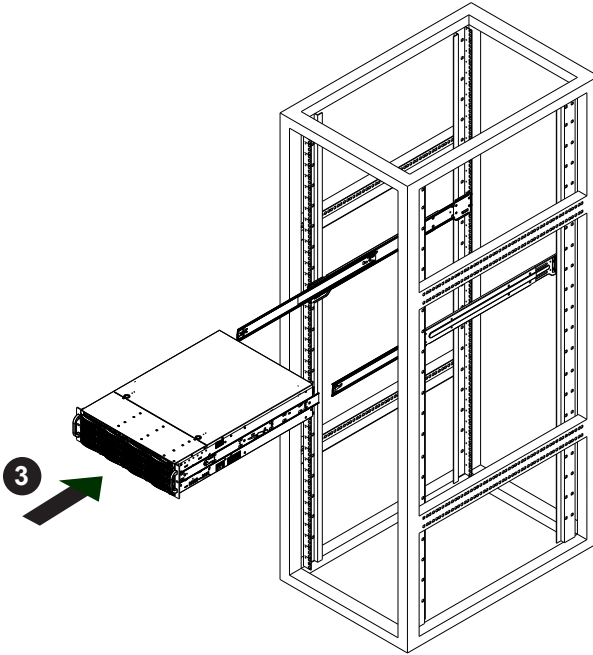

Figure 7-4: Installing the Chassis into the Server Rack

Installing the Chassis into a Rack

1. Confirm outer rails are installed on the rack.
2. Align the inner rails with the outer rail extension.
3. Slide the inner rails into the outer rails, keeping the pressure even on both sides (it may be necessary to depress the locking tabs when inserting). When the server has been pushed completely into the rack, the locking tabs will "click into the secure, locked position.
4. (Optional) Insert and tighten the thumbscrews which secure the server to the rack.

Appendix A

SC837J Cables and Hardware

A-1 Overview

This appendix lists supported cables for your chassis system. It only includes the most commonly used components and configurations. For more compatible cables, refer to the manufacturer of the motherboard you are using and our Web site at: www.supermicro.com.

A-2 Cables Included with SC837J Chassis (SAS/SATA)

SC837J			
Part #	Type	Length	Description
CBL-0102L	Cable	51 cm	I ² C cable for the SATA LED
CBL-0386L	Cable	---	4-port (two in and two out) external to internal iPass connector.
CBL-0108L-02	Cable	39 cm	iPass to iPass PBF.
CBL-0421L	Cable	55 cm	iPass to iPass PBF.

A-3 Compatible Cables

These cables are compatible with the SC837J chassis.

Alternate SAS/SATA cables

Some compatible motherboards have different connectors. These cables must be purchased separately.

Cable Name: SAS Cable

Quantity: 4

Part #: CBL-0175L

Alt. Name: "Big Four"

Description: This cable has one SFF-8484 (32-pin) connector on one end and four SAS connectors (seven pins each) at the other. This cable connects from the host (motherboard or other controller) to the backplane SAS hard drive port.

Cable Name: SAS Cable

Quantity: 4

Part #: CBL-0116

Alt. Name: iPass or "Small Four"

Description: This cable has one iPass (SFF-8087/Mini-SAS) connector (36-pin) at one end and four SAS connectors on one end. This cable connects from the host (motherboard or other controller) to the backplane SAS hard drive port.

Extending Power Cables

Although Supermicro chassis are designed with to be efficient and cost-effective, some compatible motherboards have power connectors located in different areas.

To use these motherboards you may have to extend the power cables to the motherboards. To do this, use the following chart as a guide.

Power Cable Extenders		
Number of Pins	Cable Part #	Length
24-pin	CBL-0042	7.9" (20 cm)
20-pin	CBL-0059	7.9" (20 cm)
8-pin	CBL-0062	7.9" (20 cm)
4-pin	CBL-0060	7.9" (20 cm)

Front Panel to the Motherboard

The SC837J chassis includes a cable to connect the chassis front panel to the motherboard. If your motherboard uses a different connector, use the following list to find a compatible cable.

Front Panel to Motherboard Cable (Ribbon Cable)		
Number of Pins (Front Panel)	Number of Pins (Motherboard)	Cable Part #
16-pin	16-pin	CBL-0049
16-pin	20-pin	CBL-0048
20-pin	20-pin	CBL-0047
16-pin	various*	CBL-0068
20-pin	various*	CBL-0067

* Split cables: Use these cable if your motherboard requires several different connections from the front panel.

A-4 Chassis Screws

The accessory box includes all the screws needed to set up your chassis. This section lists and describes the most common screws used. Your chassis may not require all the parts listed.

M/B



Pan head
6-32 x 5 mm
[0.197]

HARD DRIVE



Flat head
6-32 x 5 mm
[0.197]

DVD-ROM, CD-ROM, and FLOPPY DRIVE



Pan head
6-32 x 5 mm
[0.197]



Flat head
6-32 x 5 mm
[0.197]



Round head
M3 x 5 mm
[0.197]



Round head
M2.6 x 5 mm
[0.197]

RAIL



Flat head
M4 x 4 mm
[0.157]



Round head
M4 x 4 mm
[0.157]



Flat head
M5 x 12 mm [0.472]
Washer for M5



M/B STANDOFFS



M/B standoff
6-32 to 6-32



M/B (CPU)
standoff
M5 to 6-32



Thumb screw
6-32 x 5 mm
[0.197]



1/2 M/B standoff
6-32 x 5 mm
[0.197]



Appendix B

SC837J Power Supply Specifications

This appendix lists power supply specifications for your chassis system.

SC837J	
	1620W
MFR Part #	PWS-1K62P-1R
AC Input	1000W: 100-120 V, 50-60 Hz, 12-10 Amp 1200W: 120-140 V, 50-60 Hz, 12-10 Amp 1620W: 180-240 V, 50-60 Hz, 10.5-8 Amp
DC Output +5V Standby	4 Amp
DC Output +12V	1000W: 84 Amp 1200W: 100 Amp 1620W: 135 Amp



Notes

Appendix C

SAS2-837EL Backplane Specifications

To avoid personal injury and property damage, carefully follow all the safety steps listed below when accessing your system or handling the components.

C-1 ESD Safety Guidelines

Electrostatic Discharge (ESD) can damage electronic components. To prevent damage to your system, it is important to handle it very carefully. The following measures are generally sufficient to protect your equipment from ESD.

- Use a grounded wrist strap designed to prevent static discharge.
- Touch a grounded metal object before removing a component from the antistatic bag.
- Handle the backplane by its edges only; do not touch its components, peripheral chips, memory modules or gold contacts.
- When handling chips or modules, avoid touching their pins.
- Put the backplane and peripherals back into their antistatic bags when not in use.

C-2 General Safety Guidelines

- Always disconnect power cables before installing or removing any components from the computer, including the backplane.
- Disconnect the power cable before installing or removing any cables from the backplane.
- Make sure that the backplane is securely and properly installed on the motherboard to prevent damage to the system due to power shortage.

C-3 An Important Note to Users

All images and layouts shown in this user's guide are based upon the latest PCB revision available at the time of publishing. The card you have received may or may not look exactly the same as the graphics shown in this manual.

C-4 Introduction to the SAS2-837EL Backplane

The SAS2-837EL backplane has been designed to utilize the most up-to-date technology available, providing your system with reliable, high-quality performance.

This manual reflects SAS2-837EL1 and SAS2-837EL2 Revision 1.00, the most current release available at the time of publication. Always refer to the Supermicro Web site at www.supermicro.com for the latest updates, compatible parts and supported configurations.

The SAS2-837EL1 backplane includes a primary expander chip and primary SAS connectors. The SAS2-837EL2 includes of both primary and secondary expander chips, as well as primary and secondary SAS connectors. The primary and secondary expanders are redundant, so that if one should fail, the other will take over.

C-5 Front Connectors

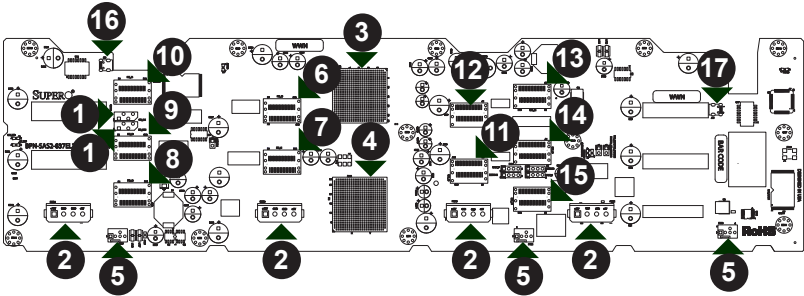

Figure C-1: Front Connectors

Front Connectors

- | | |
|---|--|
| <ol style="list-style-type: none"> 1. Dual primary I²C connectors:
PRI_I²C and PRI_I²C1 2. Power connectors:
PWR1, PWR2, PWR3 and PWR4 3. Primary expander chip 4. Secondary expander chip
(Not present on the SAS2-837EL1 backplane) 5. Fan connectors: FAN1, FAN2 and FAN3 6. Primary SAS port: PRI_J0 7. Primary SAS port: PRI_J1 8. Primary SAS port: PRI_J2 9. Primary SAS port: PRI_J3 10. Primary SAS port PRI_J4 | <ol style="list-style-type: none"> 11. Secondary SAS port: SEC_J0
(Not present on the SAS2-837EL1 backplane) 12. Secondary SAS port SEC_J1
(Not present on the SAS2-837EL1 backplane) 13. Secondary SAS port SEC_J2
(Not present on the SAS2-837EL1 backplane) 14. Secondary SAS port SEC_J3
(Not present on the SAS2-837EL1 backplane) 15. Secondary SAS port SEC_J4
(Not present on the SAS2-837EL1 backplane) 16. Primary Ethernet port: J24 17. Secondary Ethernet port: J25
(Not present on the SAS2-837EL1 backplane) |
|---|--|

C-6 Front Connector and Pin Definitions

1. Primary I²C Connector

The I²C connector is used to monitor the power supply status and to control the fans. See the table on the right for pin definitions.

I ² C Connector Pin Definitions	
Pin#	Definition
1	Data
2	Ground
3	Clock
4	No Connection

2. Backplane Main Power Connectors

The 4-pin connectors, designated PWR1, PWR2 and PWR3 provide power to the backplane. See the table on the right for pin definitions.

Backplane Main Power 4-Pin Connector	
Pin#	Definition
1	+12V
2 and 3	Ground
4	+5V

3. and 4. Primary and Secondary Expander Chips

The primary and secondary expander chips allow the SAS2-837EL2 backplane to support dual ports, cascading, and failover. SAS2-837EL1 supports cascading.

5. Fan Connectors

The 4-pin connectors, designated FAN1, through FAN3, provide power to the fans. See the table on the right for pin definitions.

Fan Connectors	
Pin#	Definition
1	Ground
2	+12V
3	Tachometer
4	Empty

6. - 15. SAS Ports

The primary and secondary sets of SAS ports provide expander features including cascading and failover. The primary SAS ports are located on the left side of the board, and are designated Primary 0 through Primary 4. The secondary SAS ports are on the right side of the board and are designated Secondary 0 through Secondary 4. Note that secondary SAS ports are not present on the SAS2-837EL1 backplane.

16. - 17. Primary and Secondary Ethernet Ports

The primary and secondary Ethernet ports are designated J24 (primary) and J25 (secondary). The secondary Ethernet ports are not present on the SAS2-837EL1 backplane.

C-7 Front Jumper Locations and Pin Definitions

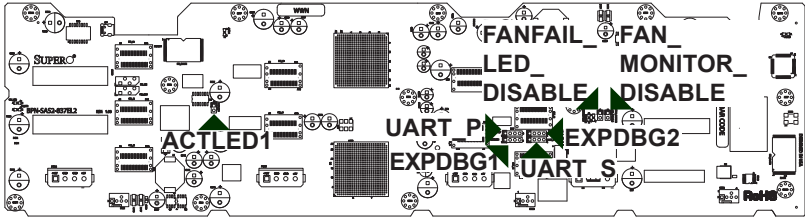
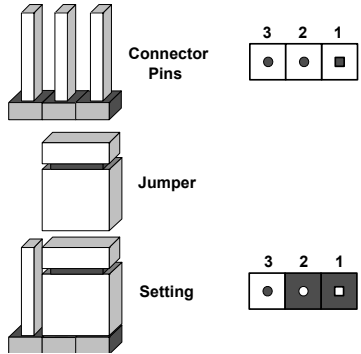

Figure C-2: Front Jumpers

General Jumper Settings		
Jumper	Jumper Settings	Note
UART_P	No jumper required	Primary UART connector
UART_S	No jumper required	Secondary UART connector (Not present on SAS2-847E1)
ACTLED1	Open: Disable Closed: Enable	For manufacturing use only
FAN_MONITOR_DISABLE	Open: Enable Closed: Disable	Fan monitor settings
FANFAIL_LED_DISABLE	Open: Enable Closed: Disable	Disables the fan failure LED
EXPDBG1	N/A	For manufacturing use only.
EXPDBG2	N/A	For manufacturing use only (Not present on SAS2-847E1)

Explanation of Jumpers

To modify the operation of the backplane, jumpers can be used to choose between optional settings. Jumpers create shorts between two pins to change the function of the connector. Pin 1 is identified with a square solder pad on the printed circuit board. Note: On two pin jumpers, "Closed" means the jumper is on and "Open" means the jumper is off the pins.



C-8 Front LED Indicators

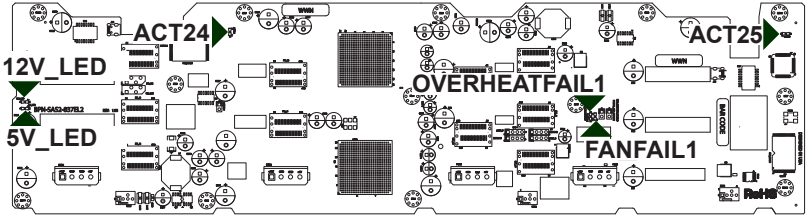

Figure C-3: Front LED Indicators

Front LEDs		
LED	Default State	Specification
5V_LED1	On	Blue LED indicates backplane power activity. Light is on during normal operation
12V_LED2	On	Blue LED indicates backplane power activity. Light is on during normal operation.
ACT24	On	Indicates activity in the primary section of the backplane.
ACT25	On	Indicates activity in the secondary section of the backplane. (Not present on SAS2-837EL1 backplane)
OVERHEATFAIL1	Off	Red LED indicates an overheated condition. Light is off during normal operation
FANFAIL1	Off	Red LED indicates a fan failure. Light is off during normal operation

Activation of the OVERHEATFAIL1 and FANFAIL1 LEDs indicate that a condition requiring immediate attention has occurred.

These LEDs are triggered by the following conditions:

1. A fan failure triggers the FANFAIL1 LED.
2. A system temperature over 45° Celsius triggers the OVERHEATFAIL1 LED.

C-9 Rear Connectors and LED Indicators

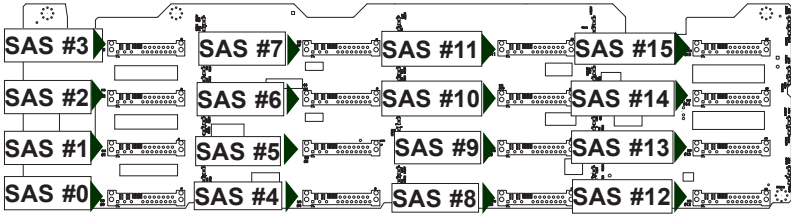

Figure C-4: Rear Connectors

Rear SAS/SATA Connectors			
Rear Connector	SAS Drive Number	Rear Connector	SAS Drive Number
SAS #0	SAS/SATA HDD #0	SAS #8	SAS/SATA HDD #8
SAS #1	SAS/SATA HDD #1	SAS #9	SAS/SATA HDD #9
SAS #2	SAS/SATA HDD #2	SAS #10	SAS/SATA HDD #10
SAS #3	SAS/SATA HDD #3	SAS #11	SAS/SATA HDD #11
SAS #4	SAS/SATA HDD #4	SAS #12	SAS/SATA HDD #12
SAS #5	SAS/SATA HDD #5	SAS #13	SAS/SATA HDD #13
SAS #6	SAS/SATA HDD #6	SAS #14	SAS/SATA HDD #14
SAS #7	SAS/SATA HDD #7	SAS #15	SAS/SATA HDD #15

Rear LED Indicators					
Rear Connector	Hard Drive Activity LED	Failure LED	Rear Connector	Hard Drive Activity LED	Failure LED
SAS #0	ACT #0	FAIL #0	SAS #8	ACT #8	FAIL #8
SAS #1	ACT #1	FAIL #1	SAS #9	ACT #9	FAIL #9
SAS #2	ACT #2	FAIL #2	SAS #10	ACT #10	FAIL #10
SAS #3	ACT #3	FAIL #3	SAS #11	ACT #11	FAIL #11
SAS #4	ACT #4	FAIL #4	SAS #12	ACT #12	FAIL #12
SAS #5	ACT #5	FAIL #5	SAS #13	ACT #13	FAIL #13
SAS #6	ACT #6	FAIL #6	SAS #14	ACT #14	FAIL #14
SAS #7	ACT #7	FAIL #7	SAS #15	ACT #15	FAIL #15

C-10 Single and Dual Port Expanders

Single Ports

SAS2-837EL1 backplanes have a single-port expander that access all hard drives and supports cascading.

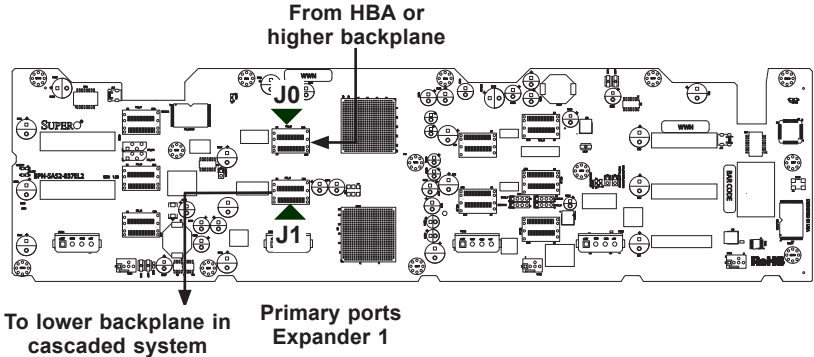

Dual Ports

SAS2-837EL2 backplanes have dual-port expanders that access all the hard drives. These dual-port expanders support cascading, failover, and multipath.

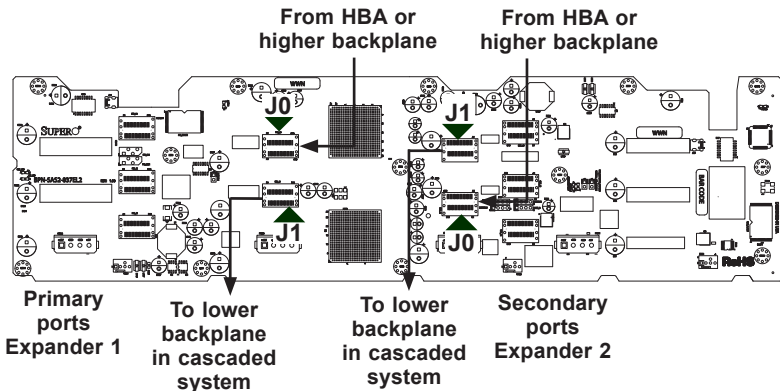

Figure C-5: Single and Dual Port Cascading Configurations

C-11 Failover

The SAS2-837EL2 backplane has two expanders which allow effective failover.

Single Host Bus Adapter

In a single host bus configuration, the backplane connects to one Host Bus Adapter (HBA).

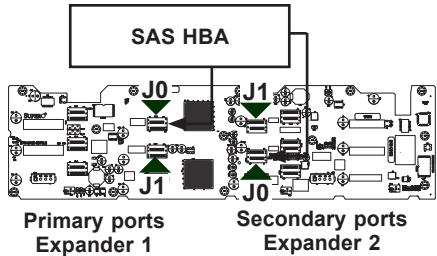

Single Host Bus Adapter Failover

If the expander or data path in the primary ports fails, the system automatically switches to the secondary ports.

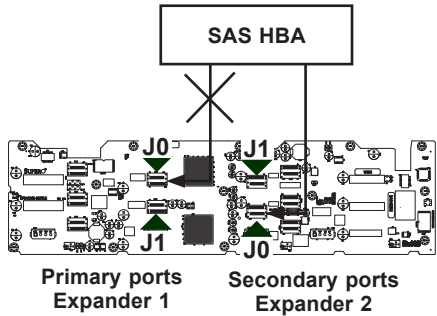

Figure C-6: Single HBA Failover Configurations

C-12 Failover with RAID Cards and Multiple HBAs

The SAS-837EL2 backplane may be configured for failover with multiple HBAs using either RAID controllers or HBAs to achieve failover protection.

RAID Controllers: If RAID controllers are used, then the failover is accomplished through port failover on the same RAID card.

HBAs: If multiple HBAs are used to achieve failover protection and load balancing, **Linux MPIO software must be installed and correctly configured to perform the load balancing and failover tasks.**

Dual Host Bus Adapter

In a dual host bus configuration, the backplane connects to two Host Bus Adapters.

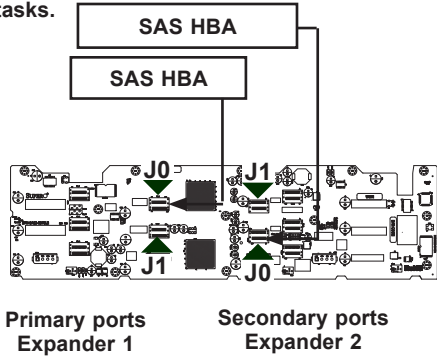

Dual Host Bus Adapter Failover

If the expander or data path in the primary ports fails, the system automatically switches to the secondary ports. This maintains a full connection to all drives. Note that this configuration requires additional MPIO software. Contact your Supermicro authorized repre-

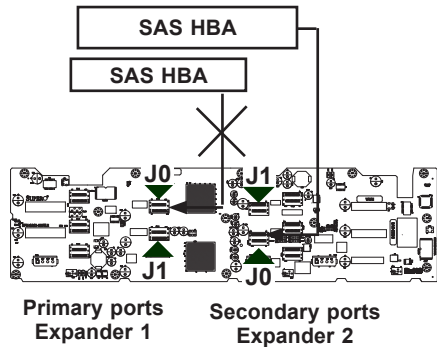

Figure C-7: Dual HBA Failover Configurations



IMPORTANT: For RAID controllers, redundancy is achieved through port failover. For multiple HBAs MPIO software is required to achieve failover protection.

C-13 Chassis Power Card and Support Cables

Chassis Power Card

In a cascaded configuration, the first chassis includes a motherboard and at least one host bus adapter. Other servers in this enclosed system should include a power card. This section describes the supported power card for the SAS-837EL backplane.

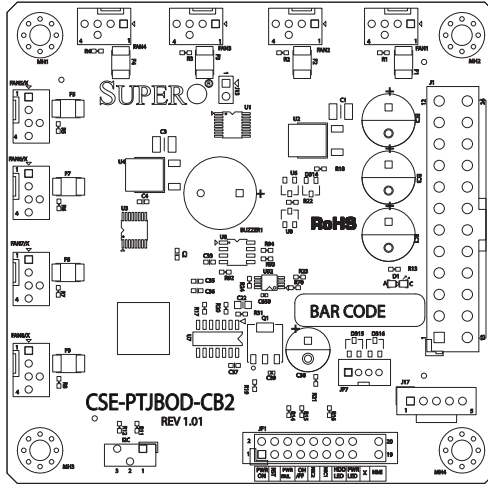

Figure C-8: Chassis Power Card (Sold Separately)

Power Card		
Part Number	Part Type	Where Used
CSE-PTJBOD-CB2	Power card	Allows the chassis to be used in a JBOD (Just a Bunch of Drives) system.

Connecting an Internal Host Bus Adapter to the Backplane

The following section lists the most common cables used to connect the HBA to the backplane.

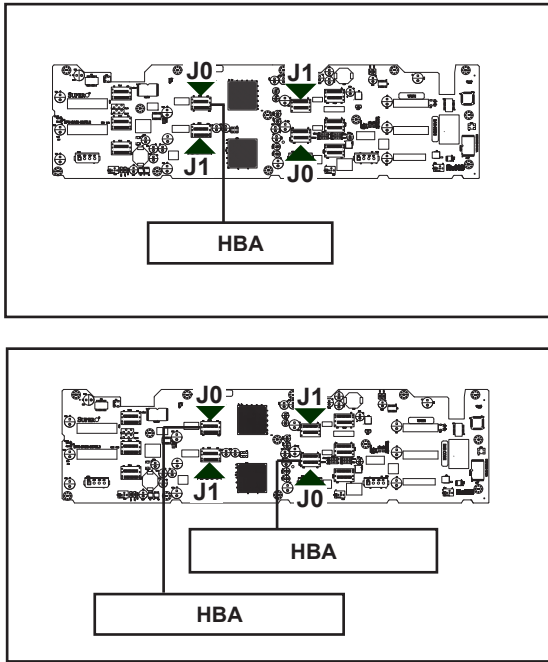

Figure C-9: Connecting an Internal HBA to the Backplane

IMPORTANT: See Section 3-3 of this manual, *Failover with RAID Cards and Multiple HBAs* for important information on supported configurations.

Supported Internal HBA Cables

Use the following listed cables to create connections between the internal HBA and SAS2-837EL backplane. The cables required depend on the HBA connector.

Cable Name: iPass to 4-lane

Part #: CBL-0117L

Length: 46 cm (18 inches)

Description: This cable has one SFF-8484 (32-pin) connector on one end and an iPass (SFF-8087/Mini-SAS) connector (36-pin) at the other. This cable connects from the HBA to the SAS2-837EL backplane.

Cable Name: iPass (Min-SAS) to iPass (Mini-SAS)

Part #: CBL-0108L-02

Length: 39 cm (15 inches)

Part #: CBL-0109L-02

Length: 22 cm (9 inches)

Part #: CBL-0110L-02

Length: 18 cm (7 inches)

Description: This cable has an iPass (SFF-8087/Mini-SAS) connector (36-pin) at each end. It connects from the HBA to the SAS2-837EL backplane.

Single HBA Configuration Cables

Single
Port Cable
Assembly

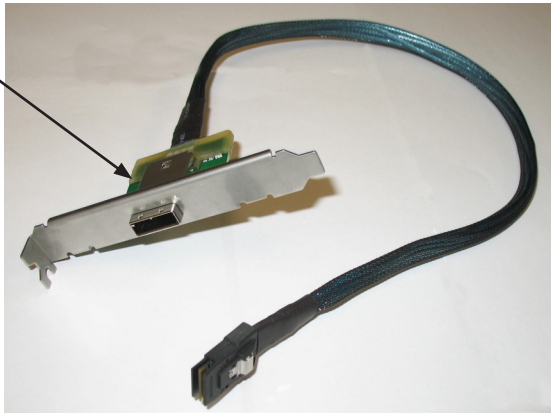

Figure C-10: Single Port Internal Cable (CBL-0167L)

Cable Name: SAS EL2/EL1 Backplane Cable (Internal) with 2-port Cascading Cable, 68 cm

Part #: CBL-0167L (SFF-8087 to SFF-8088 x1)

Ports: Single

Placement: Internal cable

Description: Internal cable. Connects the backplane to the HBA or external port. Used in single port environments.

Dual HBA Configuration Cables

Dual Port Cable
Assembly



Figure C-11: Dual Port Internal Cable (CBL-0168L)

Cable Name: SAS Dual-port Cable Assembly, 68/76 cm

Part #: CBL-0168L

Placement: Internal cable

Ports: Dual

Description: Internal cascading cable. Connects the backplane to the HBA or external port. Used in dual port environments.

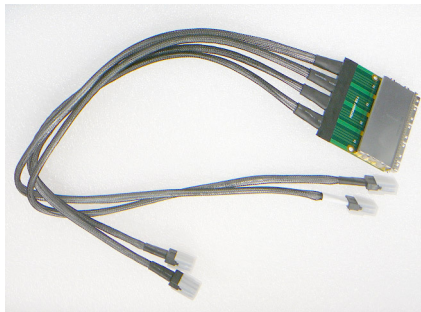

Figure C-12: External Cable (CBL-0386L)

Cable Name: Four Port iPass Connector Cable

Part #: CBL-0386L

Placement: External to internal cable

Ports: Four

Description: External to internal iPass connector cable.



Figure C-13: External Cable (CBL-0166L)

Cable Name: SAS EL2/EL1 Cascading Cable (External), 68 cm

Part #: CBL-0166L

Placement: External cable

Ports: Single or Dual

Description: External cascading cable. Connects ports between servers. Use one cable for single port connections and two cables for dual port connections.

Connecting an External Host Bus Adapter to the Backplane

This backplane supports external host bus adapters. In this configuration, the HBA and the backplane are in different physical chassis. This allows a JBOD configuration system to connect to the other system that has a HBA.

Single External Host Bus Adapter

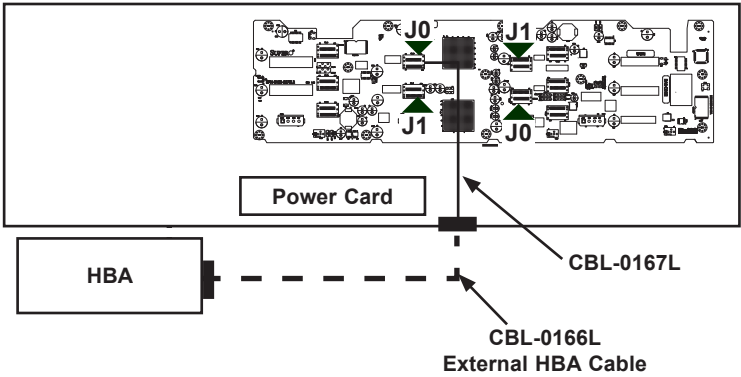

Dual External Host Bus Adapter

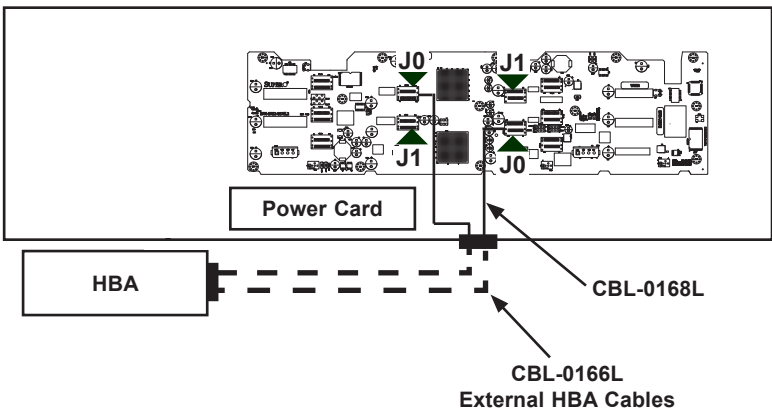

Figure C-14: Connecting Single and Dual HBAs to the Backplane

Connecting Multiple Backplanes in a Single Channel Environment

This section describes the cables used when cascading from a single HBA. These connections use CBL-0167L internal cables and CBL-0166L external cables.

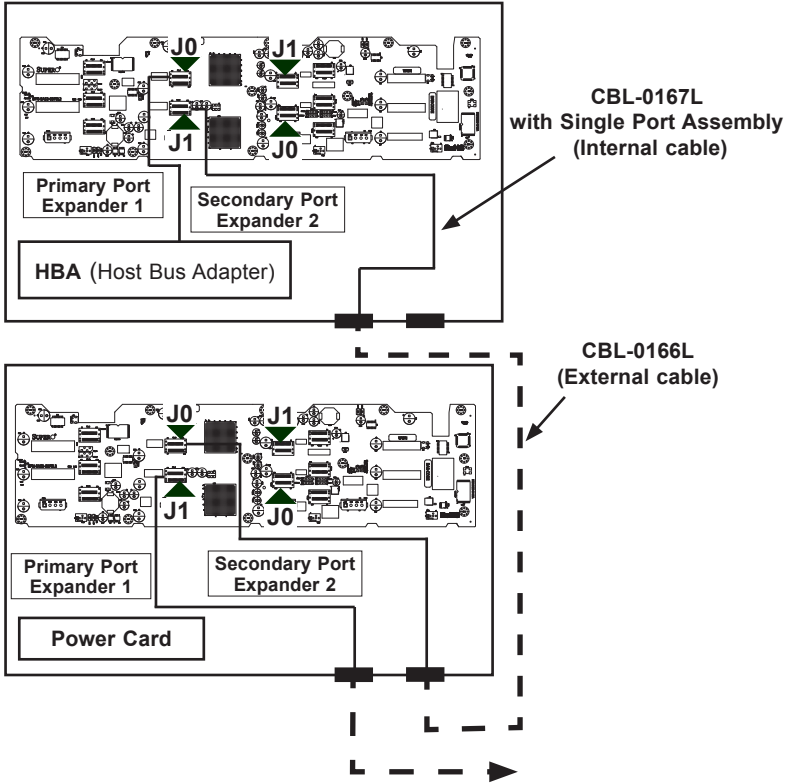

Figure C-15: Single HBA Configuration

Connecting Multiple Backplanes in a Dual Channel Environment

This section describes the cables used when cascading from dual HBAs. These connections use CBL-0168L internal cables and CBL-0166L external cables.

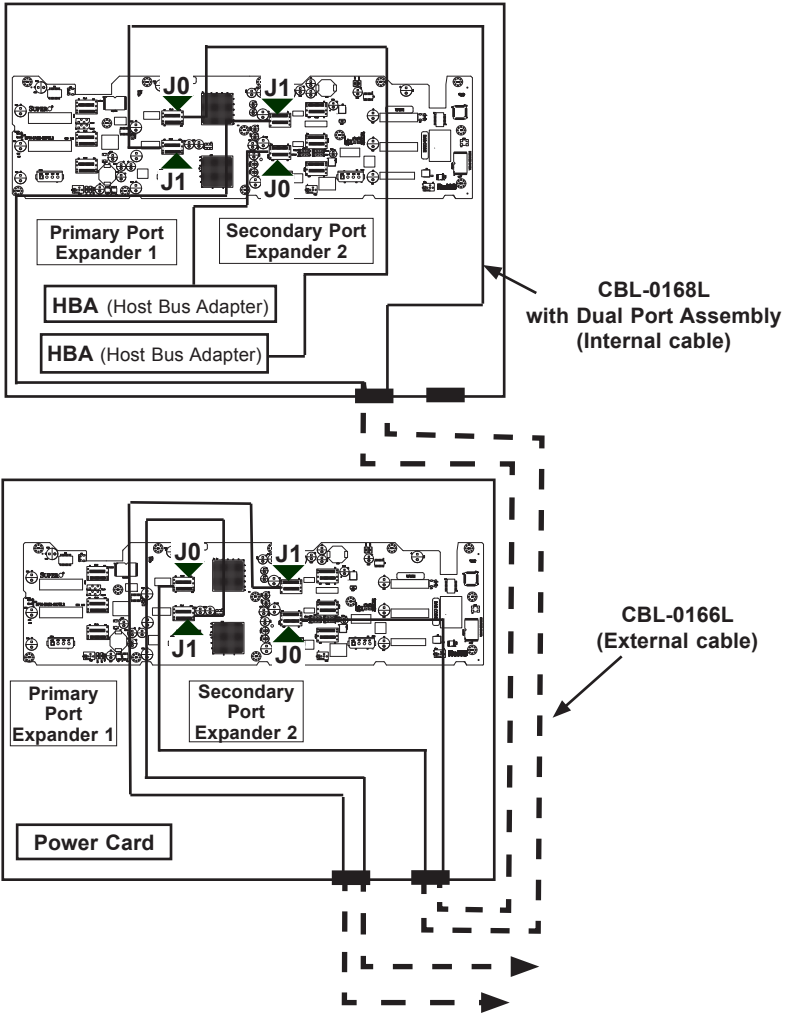

Figure C-16: Multiple Backplanes in a Dual Channel Environment

IMPORTANT: See Section C-12 of this manual, *Failover with RAID Cards and Multiple HBAs* for important information on supported configurations.

C-14 Supported Cascading Configurations

Cascading allows the system to access data at a faster rate by allowing several backplanes to share resources to reduce latency time.

The first backplane in a cascaded system requires a motherboard and an HBA. Other servers require a power control card but no motherboard and no HBA.

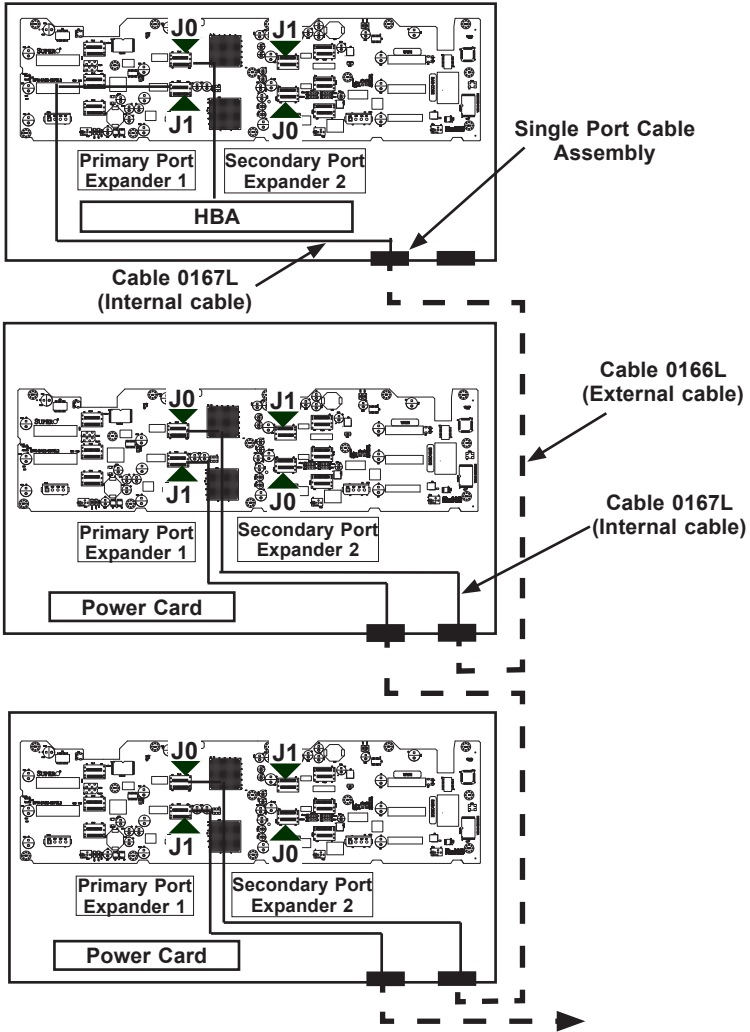

Figure C-17: Simple Cascaded Configurations

IMPORTANT: See Section C-15 of this manual *Connecting the Backplane to the Chassis* to connect the SAS2-837A and SAS-837EL Backplanes with the chassis.

Dual SAS HBA and Cascaded Configuration

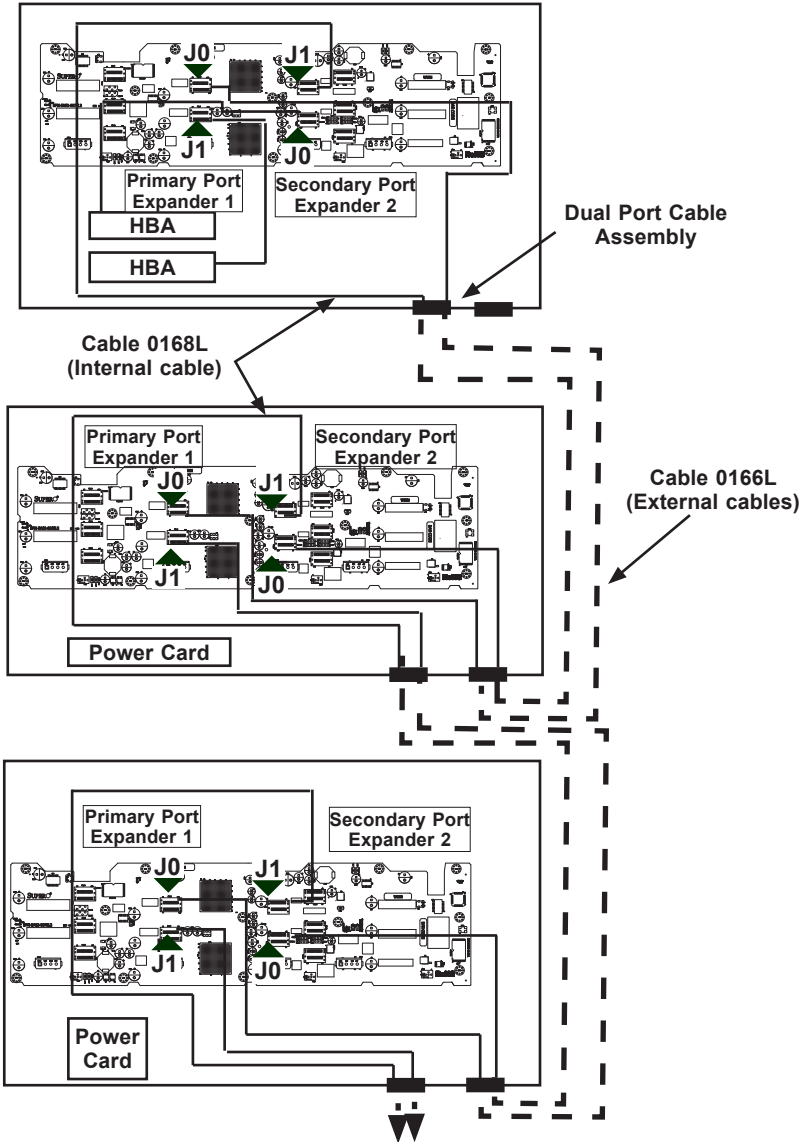

Figure C-18: Dual SAS HBA with Cascaded Configuration

IMPORTANT: See Section C-12 of this manual, *Failover with RAID Cards and Multiple HBAs* for important information on supported configurations.

IMPORTANT: See Section C-15 of this manual *Connecting the Backplane to the Chassis* to connect the SAS2-837A and SAS-837EL Backplanes with the chassis.

C-15 Connecting the Backplane to the Chassis

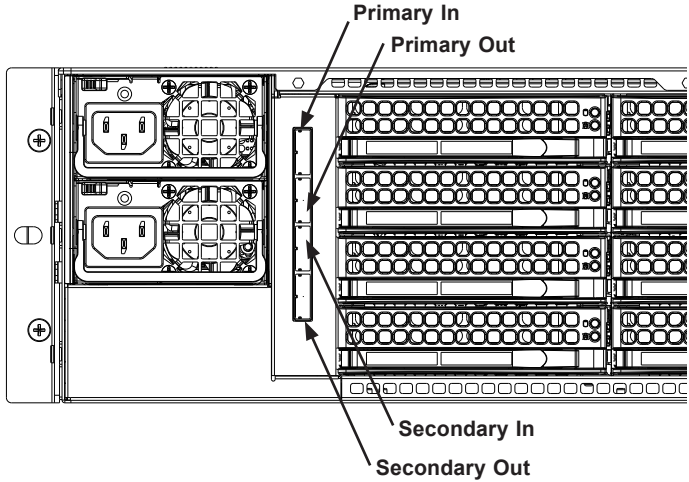

Figure C-19: Connecting the Backplane to the Chassis

When connecting the SAS2-837A or SAS-837EL backplane to the chassis as described in Section C-14, use the following chart:

Chassis Connector	Backplane Connector	Description
Primary In	Primary Port J0	From the head system or upstream cascading unit
Primary Out	Primary Port J1	To the downstream cascading unit
Secondary In	Secondary Port J0	From the head system or upstream cascading unit (Optional)
Secondary Out	Secondary Port J1	To the downstream cascading unit (Optional)

C-16 Connecting SAS2-837EL and SAS-837A Backplanes

The SAS2-837EL and SAS-837A backplanes are designed to work together. See section D-9 of this manual for instructions for connecting these backplanes.

Appendix D

SAS-837A Backplane Specifications

To avoid personal injury and property damage, carefully follow all the safety steps listed below when accessing your system or handling the components.

D-1 ESD Safety Guidelines

Electrostatic Discharge (ESD) can damage electronic components. To prevent damage to your system, it is important to handle it very carefully. The following measures are generally sufficient to protect your equipment from ESD.

- Use a grounded wrist strap designed to prevent static discharge.
- Touch a grounded metal object before removing a component from the antistatic bag.
- Handle the backplane by its edges only; do not touch its components, peripheral chips, memory modules or gold contacts.
- When handling chips or modules, avoid touching their pins.
- Put the backplane and peripherals back into their antistatic bags when not in use.

D-2 General Safety Guidelines

- Always disconnect power cables before installing or removing any components from the computer, including the backplane.
- Disconnect the power cable before installing or removing any cables from the backplane.
- Make sure that the backplane is securely and properly installed on the motherboard to prevent damage to the system due to power shortage.

D-3 An Important Note to Users

All images and layouts shown in this user's guide are based upon the latest PCB revision available at the time of publishing. The card you have received may or may not look exactly the same as the graphics shown in this manual.

D-4 Introduction to the SAS-837A Backplane

The SAS-837A backplane has been designed to utilize the most up-to-date technology available, providing your system with reliable, high-quality performance.

This manual reflects SAS-837A Revision 1.00, the most current release available at the time of publication. Always refer to the Supermicro Web site at www.supermicro.com for the latest updates, compatible parts and supported configurations.

D-5 Front Connectors

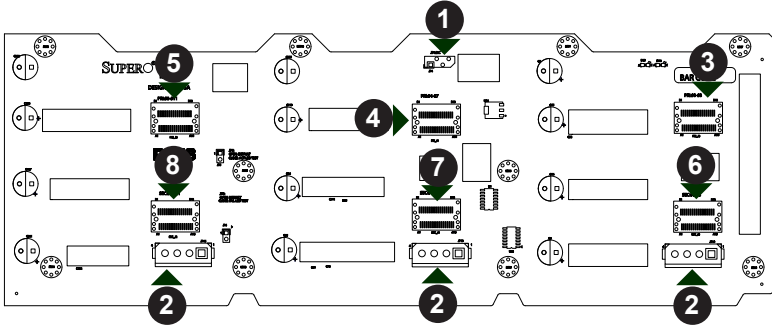

Figure D-1: Front Connectors

Front Connectors

- | | |
|--|-------------------------------|
| 1. I ² C connector: JP4: I ² C | 5. Primary SAS port: PRI_J2 |
| 2. Power connectors: JP46, JP13 and JP10. | 6. Secondary SAS port: SEC_J0 |
| 3. Primary SAS port: PRI_J0 | 7. Secondary SAS port SEC_J1 |
| 4. Primary SAS port: PRI_J1 | 8. Secondary SAS port SEC_J2 |

D-6 Front Connector and Pin Definitions

1. I²C Connector

The I²C connector is used to monitor the power supply status and to control the fans. See the table on the right for pin definitions.

I ² C Connector Pin Definitions	
Pin#	Definition
1	Data
2	Ground
3	Clock
4	No Connection

2. Backplane Main Power Connectors

The 4-pin connectors, designated JP46, JP13 and JP10 provide power to the backplane. See the table on the right for pin definitions.

Backplane Main Power 4-Pin Connector	
Pin#	Definition
1	+12V
2 and 3	Ground
4	+5V

3. - 8. SAS Ports

The primary and secondary sets of SAS ports provide expander features including cascading and failover. From right to left the ports are Primary 0 through Primary 2 and Secondary 0 through Secondary 2.

D-7 Front LED Indicators

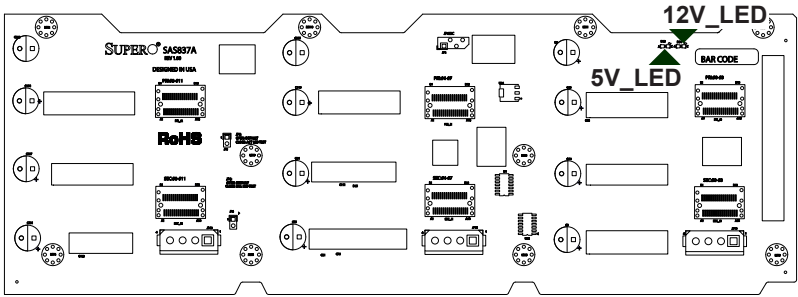

Figure D-2: Front LED Indicators

Front LEDs		
LED	Default State	Specification
5V_LED1	On	Green LED indicates backplane power activity. Light is on during normal operation
12V_LED2	On	Green LED indicates backplane power activity. Light is on during normal operation.

D-8 Rear Connectors and LED Indicators

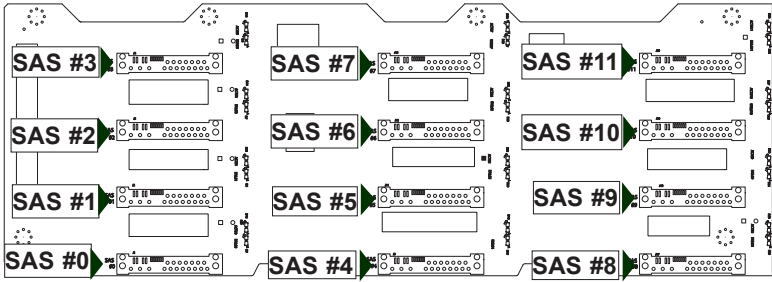

Figure D-3: Rear Connectors

Rear SAS/SATA Connectors			
Rear Connector	SAS Drive Number	Rear Connector	SAS Drive Number
SAS #0	SAS/SATA HDD #0	SAS #6	SAS/SATA HDD #6
SAS #1	SAS/SATA HDD #1	SAS #7	SAS/SATA HDD #7
SAS #2	SAS/SATA HDD #2	SAS #8	SAS/SATA HDD #8
SAS #3	SAS/SATA HDD #3	SAS #9	SAS/SATA HDD #9
SAS #4	SAS/SATA HDD #4	SAS #10	SAS/SATA HDD #10
SAS #5	SAS/SATA HDD #5	SAS #11	SAS/SATA HDD #11

Rear LED Indicators					
Rear Connector	Hard Drive Activity LED	Failure LED	Rear Connector	Hard Drive Activity LED	Failure LED
SAS #0	ACT #0	FAIL #0	SAS #6	ACT #6	FAIL #6
SAS #1	ACT #1	FAIL #1	SAS #7	ACT #7	FAIL #7
SAS #2	ACT #2	FAIL #2	SAS #8	ACT #8	FAIL #8
SAS #3	ACT #3	FAIL #3	SAS #9	ACT #9	FAIL #9
SAS #4	ACT #4	FAIL #4	SAS #10	ACT #10	FAIL #10
SAS #5	ACT #5	FAIL #5	SAS #11	ACT #11	FAIL #11

D-9 Connecting SAS-837A and SAS-837EL Backplanes

The SAS2-837EL and SAS-837A backplanes are designed to work together. The following configurations show how the SAS2-837EL and SAS-837A may be connected together.

Identifying the Backplanes

Examine the diagrams below and identify the SAS2-837EL and SAS-837A backplanes. Identify the locations of the SAS ports on each board. Also note the location of the primary I²C connectors, if the optional I²C configuration is desired.

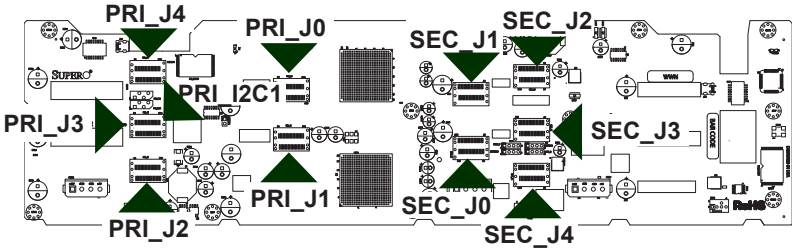

Figure D-4: SAS2-837EL Backplane

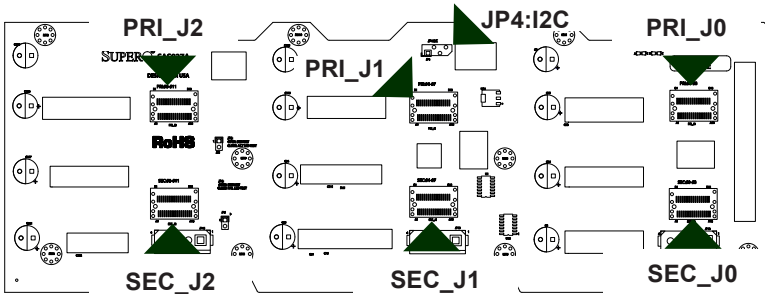

Figure D-5: SAS-837A Backplane

Configuring Dual Backplanes

Configure the SAS2-837EL2 and SAS-837A as shown in the chart below. Connect the port in Column A to the port in the Column B using the cable in Column C.

Dual Backplane Configuration Chart		
Column A SAS2-837EL Port	Column B SAS-837A Port	Column C Cable Name
Primary SAS port PRI_J2	Primary SAS port PRI_J0	CBL-0421L
Primary SAS port PRI_J3	Primary SAS port PRI_J1	CBL-0421L
Primary SAS port PRI_J4	Primary SAS port PRI_J2	CBL-0421L
Secondary SAS port SEC_J2	Secondary SAS port SEC_J0	CBL-0421L
Secondary SAS port SEC_J3	Secondary SAS port SEC_J1	CBL-0421L
Secondary SAS port SEC_J4	Secondary SAS port SEC_J2	CBL-0421L
Primary I ² C connector PRI_I2C1 (optional)	I ² C connector JP4:I2C (optional)	CBL-0102L

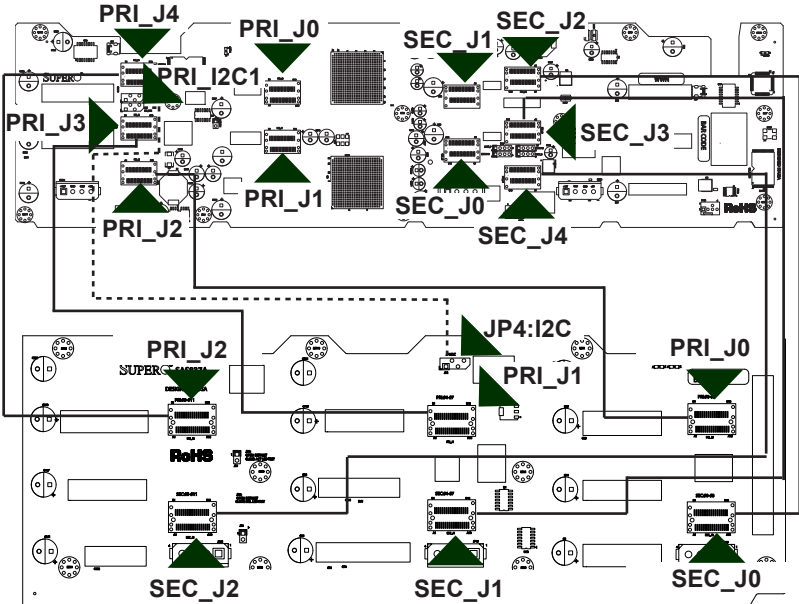

Figure D-6: SAS2-837EL Above, SAS-837A Backplane Below

Notes

Disclaimer (cont.)

The products sold by Supermicro are not intended for and will not be used in life support systems, medical equipment, nuclear facilities or systems, aircraft, aircraft devices, aircraft/emergency communication devices or other critical systems whose failure to perform be reasonably expected to result in significant injury or loss of life or catastrophic property damage. Accordingly, Supermicro disclaims any and all liability, and should buyer use or sell such products for use in such ultra-hazardous applications, it does so entirely at its own risk. Furthermore, buyer agrees to fully indemnify, defend and hold Supermicro harmless for and against any and all claims, demands, actions, litigation, and proceedings of any kind arising out of or related to such ultra-hazardous use or sale.