

# SUPERMICR<sup>®</sup>

## SuperBlade<sup>®</sup> Network Modules



**SBM-GEM-X2C+ 1/10-Gbps  
Ethernet Switch Module**



**SBM-GEM-002 1-Gbps  
Ethernet Pass-Through Module**



**SBM-GEM-001 1-Gbps  
Ethernet Switch Module**



**SBM-GEM-X3S+ 1/10-Gbps  
Ethernet Switch Module**



**SBM-XEM-F8X4SM 10-Gbps Ethernet Switch**



**SBM-IBS-Q3616/Q3616M/Q3618/F3616M  
4x QDR InfiniBand Switch Module**



**SBM-XEM-X10SM 10-Gbps Ethernet Switch**



**SBM-IBS-001 4x DDR  
InfiniBand Switch Module**



**SBM-XEM-002/M 10-Gbps Ethernet  
Pass-Through Module**



**SBM-IBP-D14 4x DDR InfiniBand  
Pass-Through Module**



**SBM-GEP-T20 1-Gbps Ethernet Pass-Through  
Module for TwinBlade™**

## User's Manual

Revision 1.2

The information in this User's Manual has been carefully reviewed and is believed to be accurate. The vendor assumes no responsibility for any inaccuracies that may be contained in this document, makes no commitment to update or to keep current the information in this manual, or to notify any person or organization of the updates. **Please Note: For the most up-to-date version of this manual, please see our web site at [www.supermicro.com](http://www.supermicro.com).**

Super Micro Computer, Inc. ("Supermicro") reserves the right to make changes to the product described in this manual at any time and without notice. This product, including software and documentation, is the property of Supermicro and/or its licensors, and is supplied only under a license. Any use or reproduction of this product is not allowed, except as expressly permitted by the terms of said license.

IN NO EVENT WILL SUPERMICRO BE LIABLE FOR DIRECT, INDIRECT, SPECIAL, INCIDENTAL, SPECULATIVE OR CONSEQUENTIAL DAMAGES ARISING FROM THE USE OR INABILITY TO USE THIS PRODUCT OR DOCUMENTATION, EVEN IF ADVISED OF THE POSSIBILITY OF SUCH DAMAGES. IN PARTICULAR, SUPERMICRO SHALL NOT HAVE LIABILITY FOR ANY HARDWARE, SOFTWARE, OR DATA STORED OR USED WITH THE PRODUCT, INCLUDING THE COSTS OF REPAIRING, REPLACING, INTEGRATING, INSTALLING OR RECOVERING SUCH HARDWARE, SOFTWARE, OR DATA.

Any disputes arising between manufacturer and customer shall be governed by the laws of Santa Clara County in the State of California, USA.. The State of California, County of Santa Clara shall be the exclusive venue for the resolution of any such disputes. Super Micro's total liability for all claims will not exceed the price paid for the hardware product.

FCC Statement: This equipment has been tested and found to comply with the limits for a Class A digital device pursuant to Part 15 of the FCC Rules. These limits are designed to provide reasonable protection against harmful interference when the equipment is operated in a commercial environment. This equipment generates, uses, and can radiate radio frequency energy and, if not installed and used in accordance with the manufacturer's instruction manual, may cause harmful interference with radio communications. Operation of this equipment in a residential area is likely to cause harmful interference, in which case you will be required to correct the interference at your own expense.

California Best Management Practices Regulations for Perchlorate Materials: This Perchlorate warning applies only to products containing CR (Manganese Dioxide) Lithium coin cells. Perchlorate Material-special handling may apply. See [www.dtsc.ca.gov/hazardouswaste/perchlorate](http://www.dtsc.ca.gov/hazardouswaste/perchlorate) for further details.



**WARNING: HANDLING OF LEAD SOLDER MATERIALS USED IN THIS PRODUCT MAY EXPOSE YOU TO LEAD, A CHEMICAL KNOWN TO THE STATE OF CALIFORNIA TO CAUSE BIRTH DEFECTS AND OTHER REPRODUCTIVE HARM.**

Manual Revision 1.2

Release Date: February 17, 2015

Unless you request and receive written permission from Super Micro Computer, Inc., you may not copy any part of this document.

Information in this document is subject to change without notice. Other products and companies referred to herein are trademarks or registered trademarks of their respective companies or mark holders.

Copyright © 2014 by Super Micro Computer, Inc.  
All rights reserved.

**Printed in the United States of America**

---

---

# Preface

## About this Manual

This manual is written for professional system integrators, Information Technology professionals, service personnel and technicians. It provides information for the installation and use of Supermicro's network modules. Installation and maintenance should be performed by experienced professionals only.

## Manual Organization

### Chapter 1: Introduction

The first chapter provides an overview of this manual.

### Chapter 2: System Safety

You should familiarize yourself with this chapter for a general overview of safety precautions that should be followed when installing and servicing Superblade Network Modules.

### Chapter 3: Setup and Installation

Refer here for details on installing the modules into a SuperBlade enclosure and for their setup and configuration.

### Chapter 4: InfiniBand Modules

This chapter details the InfiniBand modules and their features.

### Chapter 5: Ethernet Modules

This chapter details all Ethernet switches and pass-through modules for the SuperBlade system.

### Chapter 6: 1-Gb Ethernet Switch Firmware

This chapter details 1-Gb switch firmware menus and screens and how to use them.

### Chapter 7: Layer 2/3 Ethernet Switch Firmware

This chapter details 1/10-Gb switch firmware menus and screens and how to use them.

### Appendix A: HCA Mezzanine Cards

This appendix details the HCA mezzanine cards that can be installed in blade modules for use with the InfiniBand or 1/10-Gb switch modules.

### Appendix B: LED Descriptions

LED descriptions are summarized here in this appendix for quick reference.

### Appendix C: Installing Triple Wide Bays

This appendix describes and details how to use and set up triple-wide bays.

## Notes

---



---

# Table of Contents

<b>Chapter 1 Introduction</b> .....	1-1
1-1 Overview.....	1-1
1-2 Product Checklist of Typical Components.....	1-1
1-3 Features.....	1-1
1-4 Contacting Supermicro.....	1-2
<b>Chapter 2 Standardized Warning Statements</b> .....	2-1
2-1 About Standardized Warning Statements.....	2-1
Warning Definition.....	2-1
Installation Instructions .....	2-3
Circuit Breaker .....	2-4
Power Disconnection Warning .....	2-5
Equipment Installation.....	2-6
Restricted Area .....	2-7
Battery Handling .....	2-9
Redundant Power Supplies .....	2-10
Backplane Voltage .....	2-11
Comply with Local and National Electrical Codes.....	2-12
Product Disposal.....	2-13
Hot Swap Fan Warning .....	2-14
Power Cable and AC Adapter .....	2-15
<b>Chapter 3 Setup and Installation</b> .....	3-1
3-1 Installing/Removing a Switch Module .....	3-1
Installing a Switch Module .....	3-1
Removing a Switch Module .....	3-3
3-2 Configuring the Switch Module .....	3-4
Web-based Management Utility/IPMI .....	3-5
Network Connection.....	3-5
Address Defaults.....	3-7
Command Line.....	3-8
3-3 Locating and Identifying Switches and Switch Ports on a Blade Enclosure .....	3-9
Locating and Identifying a Switch on a Blade Enclosure .....	3-9
Locating and Identifying a Switch Port on a Blade Enclosure.....	3-9

3-4 Firmware for the 1/10 Gigabit and 10-Gigabit Ethernet  
Switch Modules ..... 3-13  
    Firmware Upgrading Procedures ..... 3-13  
    Firmware Failure Recovery Steps ..... 3-16

**Chapter 4 InfiniBand Modules** ..... 4-1  
    4-1 Overview ..... 4-1  
    4-2 SBM-IBS-001 4X DDR InfiniBand Switch Module ..... 4-2  
    4-3 SBM-IBS-Q3618/Q3616 4X QDR InfiniBand Switch  
    Modules ..... 4-3  
    4-4 SBM-IBS-Q3618M/SBM-IBS-Q3616M 4X QDR InfiniBand  
    Switch Modules ..... 4-4  
    4-5 SBM-IBS-F3616M 4X FDR InfiniBand Switch Module ..... 4-6  
    4-6 SBM-IBP-D14 InfiniBand Pass-Through Module ..... 4-8  
    4-7 Installation and Configuration of InfiniBand Switch Modules ..... 4-8  
        Installing/Removing the InfiniBand Switch Module ..... 4-8  
        Installing/Removing the InfiniBand Pass-Through Module ..... 4-9  
        InfiniBand Switch LEDs ..... 4-10  
        Blade Software for Access to InfiniBand Switch Module ..... 4-10

**Chapter 5 Ethernet Modules** ..... 5-1  
    5-1 SBM-GEM-001 Gigabit Ethernet Switch Module ..... 5-1  
        LED Indicators ..... 5-2  
        Ports ..... 5-2  
    5-2 SBM-GEM-X2C(+) 1/10-Gb Ethernet Switch Module ..... 5-3  
        LED Indicators ..... 5-4  
        Ports ..... 5-4  
    5-3 SBM-GEM-X3S+ 1/10-Gb Ethernet Switch Module ..... 5-5  
        LED Indicators ..... 5-6  
        Ports ..... 5-6  
    5-4 SBM-GEM-002 1-Gb Ethernet Pass-through Module ..... 5-7  
    5-5 SBM-XEM-002/M 10-Gb Ethernet Pass-through Module ..... 5-8  
    5-6 SBM-GEP-T20 1-Gb Ethernet Pass-through Module for  
    Twin-Blade Modules ..... 5-10  
    5-7 SBM-XEM-X10SM 10-Gb Ethernet Switch Module ..... 5-12  
        LED Indicators ..... 5-13  
        Ports ..... 5-13

---

5-8 SBM-XEM-F8X4SM Converged Networking	
Switch Module .....	5-14
LED Indicators .....	5-16
Ports.....	5-16
<b>Chapter 6 1-Gb Ethernet Switch Firmware .....</b>	<b>6-1</b>
6-1 SBM-GEM-001 Firmware Features and Functions .....	6-1
6-1 Port Status.....	6-4
Port VLAN ID (PVID).....	6-5
Jumbo Frames Support .....	6-5
Port Configuration .....	6-5
6-2 Statistics.....	6-7
Port Statistics .....	6-7
6-3 VLAN .....	6-10
6-4 Configuring a Static VLAN .....	6-12
6-5 Trunking.....	6-13
6-6 Mirroring.....	6-15
6-7 Quality of Service .....	6-16
Priority Queues .....	6-16
6-8 Rate Control .....	6-18
6-9 L2 Management.....	6-19
6-10 Spanning Tree .....	6-21
Bridge Protocol Data Unit (BPDU) .....	6-21
Port Transition State.....	6-22
RSTP Port Roles.....	6-22
Root Status.....	6-24
Bridge Setting.....	6-24
RSTP Port Settings.....	6-25
6-11 IEEE 802.1x .....	6-26
Wiring for 802.1x.....	6-26
802.1x Configuration.....	6-27
6-12 IGMP Snooping.....	6-28
6-13 SNMP.....	6-30
6-14 UpLink Failure Tracking (ULFT) .....	6-31
<b>Chapter 7 Layer 2/3 Ethernet Switch Firmware.....</b>	<b>7-1</b>
7-1 Overview.....	7-1
Nomenclature.....	7-2

---

7-2 Login.....	7-3
7-3 Home Page .....	7-3
Top Page Links .....	7-7
Top LED Display .....	7-7
Left Side Tree.....	7-7
Middle Configuration Link Table.....	7-8
7-4 System Management Page .....	7-8
System Settings .....	7-10
System Settings .....	7-10
System Version .....	7-12
File Management .....	7-13
Save Configuration.....	7-13
File Copy .....	7-14
File Management .....	7-14
Firmware Upgrade .....	7-15
Management Security .....	7-16
Management Security Basic Settings .....	7-16
Management User Account.....	7-17
Radius .....	7-18
TACACS+ Global Settings .....	7-19
TACACS+ Server Configuration.....	7-20
IP Authorized Manager .....	7-21
SSH Configuration .....	7-22
SSL Configuration .....	7-23
Syslog .....	7-25
Syslog Configuration .....	7-25
Syslog Mail Configuration .....	7-26
ACL .....	7-27
MAC Based ACL .....	7-27
IP Standard ACL .....	7-28
IP Extended ACL.....	7-29
WEBGUI Settings .....	7-31
SNMP.....	7-32
SNMP Community Settings.....	7-33
SNMP Group Settings.....	7-34
SNMP Group Access Settings .....	7-35
SNMP View Tree Settings.....	7-36
SNMP Target Address Settings.....	7-37
SNMP Target Parameter Settings .....	7-38
SNMP User Settings .....	7-39



---

SNMP Trap Settings .....	7-40
SNMP AgentX .....	7-41
RMON .....	7-43
RMON Basic Settings .....	7-43
Event Configuration.....	7-44
RMON Alarm Configuration .....	7-45
Ethernet Statistics Configuration .....	7-46
History Control Configuration .....	7-47
QoS .....	7-48
QOS Basic Settings .....	7-48
QOS Classmap Settings .....	7-49
QOS Policymap Settings.....	7-50
COSQ Scheduling Algorithm.....	7-51
COSQ Weight and Bandwidth Configuration .....	7-52
NTP Settings.....	7-53
Stack .....	7-54
CX4 Cable Length.....	7-55
Enabling Stacking .....	7-56
Stack Configuration .....	7-59
Stack Details .....	7-60
Stack Link Status.....	7-61
Stack Counters.....	7-62
Reload.....	7-63
<b>7-5 Layer 2 Management.....</b>	<b>7-64</b>
Layer 2 Basic Settings .....	7-65
Port Manager .....	7-66
Port Basic Settings.....	7-66
Port Monitoring.....	7-68
VLAN Traffic Class .....	7-69
Port Control.....	7-70
Rate Limiting .....	7-71
VLAN.....	7-72
VLAN Basic Settings .....	7-72
Port Settings.....	7-73
Static VLAN .....	7-74
Protocol Group.....	7-75
Port Protocol .....	7-75
Vlan Port MAC Map .....	7-76
Unicast MAC .....	7-77
Wildcard .....	7-78

---

Switch Port VLAN.....	7-79
Dynamic Vlan.....	7-80
Dynamic VLAN Global Configuration .....	7-80
Port Configuration .....	7-81
GARP Timers .....	7-82
RSTP .....	7-83
RSTP Global Settings .....	7-83
RSTP Basic Settings.....	7-84
Port Settings.....	7-85
Port Status.....	7-86
MSTP .....	7-87
MSTP Basic Settings .....	7-87
MSTP Timers .....	7-89
Port Configuration .....	7-90
VLAN Mapping.....	7-91
Port Settings.....	7-92
CIST Port Status .....	7-93
LA (Link Aggregation) .....	7-95
LA Basic Settings .....	7-95
Interface Settings .....	7-96
Port Channel .....	7-97
Port Settings.....	7-98
Port State Info .....	7-99
Load Balancing .....	7-100
802.1x .....	7-101
Basic Settings .....	7-101
Port Settings.....	7-102
Timers .....	7-104
Local AS.....	7-105
MAC Session Info .....	7-106
Filters .....	7-107
Unicast Filters .....	7-107
Multicast Filters .....	7-108
7-6 Layer 3 Management.....	7-109
IP.....	7-110
Vlan Interface .....	7-110
IP V4 Interface Settings .....	7-111
IP Route .....	7-112
LoopBack Basic Settings .....	7-113
IP V6 .....	7-114

---



---

IPv6 Route Configuration .....	7-114
IPv6 Interface .....	7-115
ND Cache.....	7-116
Address Settings.....	7-117
Address Profile.....	7-118
Prefix Settings.....	7-119
DHCP Server .....	7-120
DHCP Basic Settings .....	7-120
Pool Settings.....	7-121
DHCP Relay.....	7-122
DHCP Relay Basic Settings.....	7-122
Interface Settings .....	7-123
RIP .....	7-124
RIP Basic Settings .....	7-124
Interfaces .....	7-125
Neighbors List .....	7-126
Security Settings .....	7-127
Address Summarization .....	7-128
RIPng.....	7-129
RIP6 Interface .....	7-129
Filters .....	7-130
OSPF .....	7-132
OSPF Basic Settings.....	7-132
Area.....	7-133
Interface .....	7-134
Virtual Interface.....	7-135
OSPF Neighbor.....	7-136
OSPF RRD Route Configuration.....	7-137
OSPF Area Aggregation .....	7-138
External Aggregation.....	7-139
OSPF V3.....	7-141
OSPFv3 Basic Settings.....	7-141
Interface .....	7-142
Area.....	7-144
OSPF V3 External Aggregation .....	7-145
BGP .....	7-147
BGP Basic Settings.....	7-147
BGP Peer Configuration.....	7-148
BGP MED Configuration .....	7-149
Local Preference .....	7-150

BGP Filter.....	7-152
Route Aggregations .....	7-153
Advanced BGP Configuration .....	7-154
BGP Community Management .....	7-155
RRD .....	7-156
RRD Basic Settings.....	7-157
BGP.....	7-158
RIP .....	7-159
OSPF .....	7-160
RRD6 .....	7-161
RRD6 Basic Settings.....	7-161
Filters .....	7-162
RRD V6 OSPF .....	7-163
RRD RIP .....	7-164
VRRP .....	7-165
VRRP Basic Settings .....	7-165
VRRP Settings .....	7-166
7-7 Multicast.....	7-167
GMP Snooping.....	7-167
IGMP Snooping Configuration .....	7-168
IGMP Snooping Timer.....	7-169
IGMP Snooping Interface.....	7-170
IGMP Snooping VLAN Router.....	7-171
IGMP MAC Forwarding .....	7-172
Dynamic Multicast.....	7-173
Global Configuration .....	7-173
Dynamic Multicast Port Configuration .....	7-174
IGMP .....	7-175
Basic Settings .....	7-175
Interface Configuration.....	7-176
Group Information .....	7-177
Source Information.....	7-178
PIM.....	7-179
Basic Settings .....	7-179
Component.....	7-180
Interfaces .....	7-181
Candidate RPs .....	7-182
Threshold .....	7-183
Static RP .....	7-184
DVMRP .....	7-185

---

DVMRP Basic Settings .....	7-185
Interfaces .....	7-186
7-8 Statistics .....	7-187
Interface .....	7-188
Interface Statistics .....	7-188
Ethernet Statistics .....	7-189
Radius .....	7-191
TACACS+ Statistics .....	7-193
RMON Ethernet Statistics .....	7-195
SNMP Statistics .....	7-197
Agent .....	7-197
SNMP AgentX .....	7-198
VLAN .....	7-199
Current DB .....	7-200
VLAN Port Statistics .....	7-201
VLAN Multicast Table .....	7-202
VLAN Counter Statistics .....	7-203
VLAN Capabilities .....	7-204
VLAN FDB Entries .....	7-205
RSTP Statistics .....	7-206
RSTP Information .....	7-206
RSTP Port Statistics .....	7-207
MSTP Statistics .....	7-209
MSTP Information .....	7-209
MSTP CIST Statistics .....	7-210
MSTP MSTI Port Statistics .....	7-211
Link Aggregation (LA) .....	7-212
LA Port Statistics .....	7-213
LA Neighbor Statistics .....	7-214
802.1X .....	7-215
802.1X Session Statistics .....	7-215
802.1X Supplicant Statistics .....	7-216
Mac Session Statistics .....	7-217
IP .....	7-219
ARP Cache .....	7-219
ICMP Statistics .....	7-220
IPv6 .....	7-222
IP V6 Interface Statistics .....	7-222
ICMP V6 Statistics .....	7-224
RIP Statistics .....	7-226

---

RIP6.....	7-227
RIP6 Interface Statistics.....	7-227
RIP6 Route Information.....	7-228
OSPF.....	7-230
OSPF Route Information.....	7-230
OSPF Link State DB.....	7-231
OSPFv3.....	7-233
OSPFV3 Route Information.....	7-233
OSPFV3 Link State DB.....	7-234
VRRP Statistics.....	7-235
IGMP Snooping.....	7-237
IGMP Snooping Clear Statistics.....	7-237
IGMP Snooping V1/V2 Statistics.....	7-238
IGMP Snooping V3 Statistics.....	7-239
IGMP Statistics.....	7-240
PIM.....	7-242
PIM Interface Statistics.....	7-242
PIM Neighbor Statistics.....	7-243
PIM BSR Info.....	7-244
PIM RP Set Information.....	7-245
PIM Route Information.....	7-246
DVMRP.....	7-247
DVMRP Routers.....	7-247
DVMRP Multicast Routers.....	7-248
DVMRP Prune Statistics.....	7-249

<b>Appendix A HCA Mezzanine Cards.....</b>	<b>A-1</b>
A-1 Safety Guidelines.....	A-1
ESD Safety Guidelines.....	A-1
General Safety Guidelines.....	A-1
A-2 Mezzanine HCA Cards.....	A-2
AOC-IBH-001 Mezzanine HCA Card.....	A-2
AOC-IBH-002 Mezzanine HCA Card.....	A-3
AOC-IBH-003 Mezzanine HCA Card.....	A-4
AOC-IBH-XDS Mezzanine HCA Card.....	A-5
AOC-IBH-XDD Mezzanine HCA Card.....	A-6
AOC-IBH-XQS Mezzanine HCA Card.....	A-7
AOC-IBH-XQD Mezzanine HCA Card.....	A-8
AOC-XEH-iN2 Mezzanine HCA Card.....	A-9
A-3 Installation.....	A-10

---

---

Installation Location .....	A-11
Card Installation .....	A-11

## **Appendix B**

<b>LED Descriptions</b> .....	B-1
B-1 Gigabit Ethernet Module LED Descriptions .....	B-1
B-2 1/10 Gigabit Ethernet Module LED Descriptions .....	B-2
B-3 SBM-XEM-X10SM 10G and SBM-XEM-F8X4SM Ethernet Switch LED Descriptions.....	B-3
B-4 SBM-IBS-001 InfiniBand Switch LED Descriptions.....	B-4
B-5 SBM-IBS-Q3616M and SBM-IBS-Q3618M InfiniBand Switch LED Descriptions .....	B-5

## **Appendix C**

<b>Installing Triple Wide Bays</b> .....	C-1
C-1 Installing a Triple Wide Module Bay .....	C-1

## Notes



---



---

# List of Figures

Figure 3-1. Blade Enclosure with 1-Gbps Switch Modules Installed.....	3-2
Figure 3-2. Blade Enclosure with 1/10-Gbps Switch Modules Installed.....	3-3
Figure 3-3. Configuring the Switch Module .....	3-4
Figure 3-4. IPMI Login Screen .....	3-5
Figure 3-5. IPMI Blade System Screen.....	3-6
Figure 3-6. Gigabit Switch Panel.....	3-7
Figure 3-7. Displayed Text for Rebooting .....	3-14
Figure 3-8. Setting Hardware Information .....	3-15
Figure 4-1. SBM-IBS-001 InfiniBand Switch Module .....	4-2
Figure 4-2. SBM-IBS-Q3618/Q3616 InfiniBand Switch Module.....	4-3
Figure 4-3. SBM-IBS-Q3616M InfiniBand Switch Module.....	4-4
Figure 4-4. SBM-IBS-F3616M InfiniBand Switch Module .....	4-6
Figure 4-5. SBM-IBP-D14 InfiniBand Pass-Through Triple-Wide Module .....	4-8
Figure 5-1. SBM-GEM-001 Gigabit Ethernet Switch Module .....	5-1
Figure 5-2. SBM-GEM-X2C(+) 1/10-Gigabit Ethernet Switch Module Ports & Indicators.....	5-3
Figure 5-3. SBM-GEM-X3S+ 1/10-Gigabit Ethernet Switch Module Ports & Indicators.....	5-5
Figure 5-4. SBM-GEM-002 Gigabit Pass-through Module.....	5-7
Figure 5-5. SBM-XEM-002/M 10-Gigabit Pass-through Module .....	5-9
Figure 5-6. SBM-GEP-T20 Gigabit Pass-through Module .....	5-10
Figure 5-7. SBM-GEP-T20 Installed in Enclosure.....	5-11
Figure 5-8. SBM-XEM-X10SM 10 Gigabit Ethernet Switch Module Ports & Indicators.....	5-12
Figure 5-9. SBM-XEM-F8X4SM 10 Gigabit Ethernet Switch Module Ports & Indicators.....	5-14
Figure 6-1. Switch Status Screen.....	6-2
Figure 6-2. Switch System Management Screen.....	6-2
Figure 6-3. Port Status Screen.....	6-4
Figure 6-4. Jumbo Frame Setting Screen .....	6-5
Figure 6-5. Port Configuration Screen .....	6-6
Figure 6-6. Statistics Screen .....	6-7
Figure 6-7. Port Statistics Screen .....	6-8
Figure 6-8. VLAN Screen .....	6-10
Figure 6-9. Creating a New VLAN.....	6-12
Figure 6-10. New VLAN Screen.....	6-13
Figure 6-11. Trunking Screen .....	6-14
Figure 6-12. Port Mirroring Screen.....	6-15

Figure 6-13. QoS Setting Screen .....	6-17
Figure 6-14. Rate Limit and Storm Control Screen .....	6-18
Figure 6-15. Storm Control Screen .....	6-19
Figure 6-16. L2 Management Screen .....	6-20
Figure 6-17. L2 Management: Current Entries Screen .....	6-20
Figure 6-18. Rapid Spanning Tree Screen .....	6-23
Figure 6-19. Rapid Spanning Tree Port Settings .....	6-25
Figure 6-20. 802.1x Configuration Screen .....	6-27
Figure 6-21. IGMP Snooping Screen .....	6-29
Figure 6-22. Uplink Failure Tracking Configuration Screen .....	6-32
Figure 7-1. Login Page.....	7-3
Figure 7-2. Home Page.....	7-4
Figure 7-3. SBM-GEM-X2C(+) Home Page.....	7-5
Figure 7-4. SBM-XEM-X10SM Home Page.....	7-5
Figure 7-5. SSE-G24-TG4 Home Page .....	7-6
Figure 7-6. SSE-G48-TG4 Home Page .....	7-6
Figure 7-7. System Management Page .....	7-8
Figure 7-8. System Settings Page .....	7-10
Figure 7-9. System Version Page .....	7-12
Figure 7-10. File Management Page.....	7-13
Figure 7-11. Firmware Upgrade Page.....	7-15
Figure 7-12. Management Security Basic Settings Page.....	7-16
Figure 7-13. Management User Account Page.....	7-17
Figure 7-14. Radius Server Configuration Page .....	7-18
Figure 7-15. TACACS+ Global Settings Page .....	7-19
Figure 7-16. TACACS+ Server Configuration Page.....	7-20
Figure 7-17. IP Authorized Manager Page.....	7-21
Figure 7-18. SSH Configuration .....	7-22
Figure 7-19. SSL Configuration Page .....	7-23
Figure 7-20. Syslog Configuration Page .....	7-25
Figure 7-21. Syslog Mail Configuration Page.....	7-26
Figure 7-22. MAC ACL Configuration Page.....	7-27
Figure 7-23. IP Standard ACL Configuration Page .....	7-28
Figure 7-24. IP Extended ACL Page.....	7-29
Figure 7-25. Web GUI Settings Page.....	7-31
Figure 7-26. SNMP Agent Control Settings Page .....	7-32
Figure 7-27. SNMP Community Settings Page.....	7-33
Figure 7-28. SNMP Group Settings Page .....	7-34
Figure 7-29. SNMP Group Access Settings Page .....	7-35
Figure 7-30. SNMP View Tree Settings Page.....	7-36

---

Figure 7-31. SNMP Target Address Settings Page .....	7-37
Figure 7-32. SNMP Target Parameter Settings Page.....	7-38
Figure 7-33. SNMP Security Settings Page.....	7-39
Figure 7-34. SNMP Trap Settings Page.....	7-40
Figure 7-35. SNMP AgentX Subagent Settings Page.....	7-41
Figure 7-36. RMON Basic Settings Page.....	7-43
Figure 7-37. Event Configuration Settings Page.....	7-44
Figure 7-38. RMON Alarm Configuration Page.....	7-45
Figure 7-39. Ethernet Statistics Configuration Page.....	7-46
Figure 7-40. History Control Configuration Page.....	7-47
Figure 7-41. QOS Basic Settings Page.....	7-48
Figure 7-42. QOS Classmap Settings Page .....	7-49
Figure 7-43. QOS Polycymap Settings Page.....	7-50
Figure 7-44. COSQ Scheduling Algorithm Settings Page.....	7-51
Figure 7-45. COSQ Weight and Bandwidth Configurations Page.....	7-52
Figure 7-46. NTP Settings Page .....	7-53
Figure 7-47. Configuring CX4 Cable Length .....	7-55
Figure 7-48. Switch Diagram.....	7-57
Figure 7-49. Stack Configuration Page.....	7-59
Figure 7-50. Stack Details Page .....	7-60
Figure 7-51. Stack Link Status Page.....	7-61
Figure 7-52. Stack Counter Details Page.....	7-62
Figure 7-53. System Settings Page – Reload.....	7-63
Figure 7-54. Layer2 Management Page .....	7-64
Figure 7-55. MAC Address Table Settings Page .....	7-65
Figure 7-56. Port Basic Settings Page .....	7-66
Figure 7-57. Port Monitoring Page.....	7-68
Figure 7-58. VLAN Traffic Class Mapping Page .....	7-69
Figure 7-59. Port Control Page .....	7-70
Figure 7-60. Rate Limiting Page .....	7-71
Figure 7-61. VLAN Basic Settings Page .....	7-72
Figure 7-62. VLAN Port Settings Page .....	7-73
Figure 7-63. Static VLAN Configuration Page.....	7-74
Figure 7-64. VLAN Protocol Group Settings Page.....	7-75
Figure 7-65. VLAN Port MAC Map Settings Page .....	7-76
Figure 7-66. VLAN Unicast MAC Settings Page.....	7-77
Figure 7-67. Wildcard Settings Page .....	7-78
Figure 7-68. Switch Port Vlan Filtering Page .....	7-79
Figure 7-69. Dynamic VLAN Global Configuration Page .....	7-80
Figure 7-70. Dynamic VLAN Port Configuration Page .....	7-81

Figure 7-71. Garp Timers Configuration Page .....	7-82
Figure 7-72. Global Configuration Page.....	7-83
Figure 7-73. RSTP Configuration Page .....	7-84
Figure 7-74. Port Status Configuration Page .....	7-85
Figure 7-75. RSTP Port Status Page.....	7-86
Figure 7-76. Global Configuration Page.....	7-87
Figure 7-77. Timers Configuration Page.....	7-89
Figure 7-78. CIST Settings Page .....	7-90
Figure 7-79. VLAN Mapping Page .....	7-91
Figure 7-80. Port Settings Page.....	7-92
Figure 7-81. MSTP CIST Port Status Page .....	7-93
Figure 7-82. LA Basic Settings Page .....	7-95
Figure 7-83. Port Channel Interface Basic Settings Page.....	7-96
Figure 7-84. LA Port Channel Settings Page .....	7-97
Figure 7-85. LA Port Settings Page .....	7-98
Figure 7-86. LA Port State Machine Information Page .....	7-99
Figure 7-87. LA Load Balancing Policy Page.....	7-100
Figure 7-88. 802.1x Basic Settings Page.....	7-101
Figure 7-89. 802.1x Port Settings Page.....	7-102
Figure 7-90. 802.1x Timer Configuration Page.....	7-104
Figure 7-91. Local Authentication Server Configuration Page .....	7-105
Figure 7-92. MAC Session Info Page.....	7-106
Figure 7-93. L2 Unicast Filter Configuration Page .....	7-107
Figure 7-94. L2 Multicast Filter Configuration Page.....	7-108
Figure 7-95. Layer3 Management Page .....	7-109
Figure 7-96. VLAN Interface Basic Settings Page .....	7-110
Figure 7-97. IPv4 Interface Settings Page .....	7-111
Figure 7-98. IP Route Configuration Page.....	7-112
Figure 7-99. LoopBack Basic Settings Page.....	7-113
Figure 7-100. IP6 Route Configuration Page.....	7-114
Figure 7-101. IPv6 Interface Settings Page .....	7-115
Figure 7-102. ND Cache Configuration Page .....	7-116
Figure 7-103. Address Settings Page .....	7-117
Figure 7-104. Address Profile Settings Page .....	7-118
Figure 7-105. Prefix Configuration Page.....	7-119
Figure 7-106. DHCP Basic Settings Page .....	7-120
Figure 7-107. DHCP Pool Settings Page.....	7-121
Figure 7-108. DHCP Relay Configuration Page.....	7-122
Figure 7-109. DHCP Relay Interface Configuration Page.....	7-123
Figure 7-110. RIP Basic Settings Page.....	7-124

---

Figure 7-111. RIP Interface Page .....	7-125
Figure 7-112. RIP Neighbor List Page .....	7-126
Figure 7-113. RIP Security Settings Page .....	7-127
Figure 7-114. RIP Interface Specific Address Summarization Page.....	7-128
Figure 7-115. RIP6 Interface Configuration Page .....	7-129
Figure 7-116. RIP6 Filter Configuration Page .....	7-130
Figure 7-117. OSPF Basic Settings Page.....	7-132
Figure 7-118. OSPF Area Configuration Page.....	7-133
Figure 7-119. OSPF Interface Configuration Page .....	7-134
Figure 7-120. OSPF Virtual Interface Configuration Page.....	7-135
Figure 7-121. OSPF Neighbor Configuration Page.....	7-136
Figure 7-122. OSPF RRD Route Configuration Page.....	7-137
Figure 7-123. OSPF Area Aggregation Page.....	7-138
Figure 7-124. OSPF As External Aggregation Configuration Page .....	7-139
Figure 7-125. OSPFv3 Basic Settings Page .....	7-141
Figure 7-126. Interface Settings Page .....	7-142
Figure 7-127. OSPFv3 Area Settings Page .....	7-144
Figure 7-128. OSPF AS External Aggregation Configuration Page.....	7-145
Figure 7-129. BGP Basic Settings Page.....	7-147
Figure 7-130. BGP Peer Configuration Page.....	7-148
Figure 7-131. BGP MED Configuration Page .....	7-149
Figure 7-132. BGP Local Preference Configuration Page .....	7-150
Figure 7-133. BGP Filter Configuration Page .....	7-152
Figure 7-134. BGP Route Aggregation Configuration Page .....	7-153
Figure 7-135. Advanced BGP Configuration Page .....	7-154
Figure 7-136. BGP Community Management Page.....	7-155
Figure 7-137. RRD Basic Settings Page.....	7-157
Figure 7-138. RRD BGP Configuration Page.....	7-158
Figure 7-139. RRD RIP Configuration Page .....	7-159
Figure 7-140. RRD OSPF Configuration Page .....	7-160
Figure 7-141. RRD6 Basic Settings Page.....	7-161
Figure 7-142. RRD6 Filter Configuration Page .....	7-162
Figure 7-143. RRD6 OSPFv3 Configuration Page.....	7-163
Figure 7-144. RRD RIPv6 Configuration Page .....	7-164
Figure 7-145. VRRP Basic Settings Page.....	7-165
Figure 7-146. VRRP Settings Page .....	7-166
Figure 7-147. Multicast Home Page.....	7-167
Figure 7-148. IGMP Snooping Configuration Page.....	7-168
Figure 7-149. IGMP Snooping Timer Configuration Page .....	7-169
Figure 7-150. IGMP Snooping Interface Configuration Page.....	7-170

Figure 7-151. IGMP Snooping VLAN Router Ports Page .....	7-171
Figure 7-152. MAC Based Multicast Forwarding Table Page .....	7-172
Figure 7-153. Dynamic Multicast Global Configuration Page .....	7-173
Figure 7-154. Dynamic Multicast Port Configuration Page .....	7-174
Figure 7-155. IGMP Configuration Page.....	7-175
Figure 7-156. IGMP Interface Configuration Page.....	7-176
Figure 7-157. IGMP Group Configuration Page.....	7-177
Figure 7-158. IGMP Source Information Page.....	7-178
Figure 7-159. PIM Basic Settings Page .....	7-179
Figure 7-160. PIM Component Configuration Page.....	7-180
Figure 7-161. PIM Interface Configuration Page.....	7-181
Figure 7-162. Candidate RP Configuration Page.....	7-182
Figure 7-163. PIM Threshold Configuration Page.....	7-183
Figure 7-164. Static RP Configuration Page.....	7-184
Figure 7-165. DVMRP Basic Settings Page.....	7-185
Figure 7-166. DVMRP Interface Settings Page .....	7-186
Figure 7-167. Statistics Home Page .....	7-187
Figure 7-168. Interface Statistics Page.....	7-188
Figure 7-169. Ethernet Statistics Page .....	7-189
Figure 7-170. Radius Server Statistics Page .....	7-191
Figure 7-171. TACACS+ Statistics Page .....	7-193
Figure 7-172. RMON Ethernet Statistics Page .....	7-195
Figure 7-173. SNMP Statistics Page.....	7-197
Figure 7-174. VLAN Current Database Page.....	7-200
Figure 7-175. VLAN Port Statistics Page .....	7-201
Figure 7-176. VLAN Multicast Table Page.....	7-202
Figure 7-177. VLAN Counter Statistics Page.....	7-203
Figure 7-178. VLAN Capabilities Page .....	7-204
Figure 7-179. VLAN FDB Entries Page.....	7-205
Figure 7-180. RSTP Information Page.....	7-206
Figure 7-181. RSTP Port Statistics Page.....	7-207
Figure 7-182. MSTP Information Page .....	7-209
Figure 7-183. MSTP CIST Port Statistics Page .....	7-210
Figure 7-184. MSTP MSTI Port Statistics Page.....	7-211
Figure 7-185. LA Port Statistics Page.....	7-213
Figure 7-186. LA Neighbor Statistics Information Page.....	7-214
Figure 7-187. 802.1x Session Statistics Page .....	7-215
Figure 7-188. 802.1x Supplicant Session Statistics Page.....	7-216
Figure 7-189. MAC Session Statistics Page .....	7-217
Figure 7-190. ARP Cache Page.....	7-219

Figure 7-191. ICMP Statistics Page .....	7-220
Figure 7-192. IPV6 Interface Statistics Page .....	7-222
Figure 7-193. ICMPv6 Statistics Page .....	7-224
Figure 7-194. RIP Interface Statistics Page .....	7-226
Figure 7-195. RIP6 Interface Statistics Page .....	7-227
Figure 7-196. RIP6 Route Information Page .....	7-228
Figure 7-197. OSPF Route Information Page .....	7-230
Figure 7-198. OSPF Link State Database Page .....	7-231
Figure 7-199. OSPFV3 Route Information Page .....	7-233
Figure 7-200. OSPFV3 Link State Database Page .....	7-234
Figure 7-201. VRRP Statistics Page .....	7-235
Figure 7-202. IGMP Snooping Clear Statistics Page .....	7-237
Figure 7-203. IGMP Snooping V1/V2 Statistics Page .....	7-238
Figure 7-204. IGMP Snooping V3 Statistics Page .....	7-239
Figure 7-205. IGMP Route Statistics Page .....	7-240
Figure 7-206. PIM Interface Statistics Page .....	7-242
Figure 7-207. PIM Neighbor Statistics Page .....	7-243
Figure 7-208. PIM BSR Info Page .....	7-244
Figure 7-209. PIM RP Information Page .....	7-245
Figure 7-210. PIM Route Information Page .....	7-246
Figure 7-211. DVMRP Routes Page .....	7-247
Figure 7-212. DVMRP Multicast Routes Page .....	7-248
Figure 7-213. DVMRP Prune Statistics Page .....	7-249
Figure A-1. AOC-IBH-001 Mezzanine HCA Card .....	A-2
Figure A-2. AOC-IBH-002 Mezzanine HCA Card .....	A-3
Figure A-3. AOC-IBH-003 Mezzanine HCA Card .....	A-4
Figure A-4. AOC-IBH-XDS Mezzanine HCA Card .....	A-5
Figure A-5. AOC-IBH-XDD Mezzanine HCA Card .....	A-6
Figure A-6. AOC-IBH-XQS Mezzanine HCA Card .....	A-7
Figure A-7. AOC-IBH-XQD Mezzanine HCA Card .....	A-8
Figure A-8. AOC-XEH-iN2 Mezzanine HCA Card .....	A-9
Figure A-9. Installation Location .....	A-10
Figure A-10. Card Installation .....	A-12
Figure A-11. Installation Complete .....	A-12
Figure C-1. Step 1 & 2 .....	C-1
Figure C-2. Step 3 & 4 .....	C-2
Figure C-3. Step 5 .....	C-3
Figure C-4. Step 6 .....	C-4

## Notes



---



---

# List of Tables

Table 3-1. SBM-GEM-001 Switch Module Address Default Settings.....	3-7
Table 3-2. Locating and Identifying a Switch .....	3-9
Table 3-3. SBE-710 Enclosures with SBM-GEM-001/002 or SBM-GEM-X2C+/X3S+.....	3-10
Table 3-4. SBE-710 Enclosures with SBM-XEM-X10SM.....	3-10
Table 3-5. SBE-720 Enclosures with SBM-GEM-X2C+/X3S+ .....	3-10
Table 3-6. SBE-720 Enclosures with SBM-XEM-X10SM.....	3-11
Table 3-7. SBE-714 Enclosures with SBM-GEM-001/002 or SBM-GEM-X2C+/X3S+.....	3-12
Table 4-1. SBM-IBS-001 InfiniBand Module Interface .....	4-2
Table 4-2. SBM-IBS-001 InfiniBand Module Features .....	4-2
Table 4-3. SBM-IBS-Q3618/Q3616 InfiniBand Module Interface.....	4-3
Table 4-4. SBM-IBS-Q3618/Q3616 InfiniBand Module Features .....	4-3
Table 4-5. SBM-IBS-Q3618M/SBM-IBS-Q3616M InfiniBand Module Interface .....	4-4
Table 4-6. SBM-IBS-Q3618M/SBM-IBS-Q3616M InfiniBand Module Features .....	4-5
Table 4-7. SBM-IBS-F3616M InfiniBand Module Interface .....	4-6
Table 4-8. SBM-IBS-F3616M InfiniBand Module Features.....	4-7
Table 5-1. SBM-GEM-001 Gigabit Ethernet Switch Module Interface .....	5-1
Table 5-2. GEM-001 Gigabit Ethernet Switch Module Features .....	5-2
Table 5-3. SBM-GEM-001 Gigabit Ethernet Switch Module Ports.....	5-2
Table 5-4. SBM-GEM-X2C(+) 1/10-Gigabit Ethernet Switch Module Interface .....	5-3
Table 5-5. SBM-GEM-X2C(+) 1/10-Gigabit Ethernet Switch Module Features.....	5-4
Table 5-6. SBM-GEM-X2C(+) Ports.....	5-4
Table 5-7. SBM-GEM-X3S+ 1/10-Gigabit Ethernet Switch Module Interface .....	5-5
Table 5-8. SBM-GEM-X3S+ 1/10-Gigabit Ethernet Switch Module Features .....	5-6
Table 5-9. SBM-GEM-X3S+ Ports .....	5-6
Table 5-10. SBM-GEM-002 Gigabit Pass-through Module Interface .....	5-7
Table 5-11. SBM-GEM-002 Gigabit Ethernet Pass-through Module Features.....	5-8
Table 5-12. SBM-XEM-002/M 10-Gigabit Pass-through Module Interface .....	5-9
Table 5-13. SBM-XEM-002/M 10-Gigabit Pass-through Module Features.....	5-9
Table 5-14. SBM-GEP-T20 Gigabit Pass-through Module Interface .....	5-10

Table 5-15. SBM-GEP-T20 Gigabit Ethernet Pass-through Module Features .....	5-11
Table 5-16. SBM-XEM-X10SM 10 Gigabit Ethernet Switch Module Interface .....	5-12
Table 5-17. SBM-XEM-X10SM 10 Gigabit Ethernet Switch Module Features .....	5-13
Table 5-18. SBM-XEM-X10SM Ports .....	5-13
Table 5-19. SBM-XEM-F8X4SM 10 Gigabit Ethernet Switch Module Interface .....	5-15
Table 5-20. SBM-XEM-F8X4SM 10 Gigabit Ethernet Switch Module Features .....	5-15
Table 5-21. SBM-XEM-F8X4SM Ports .....	5-16
Table 6-1. SBM-GEM-001 Software Features and Functions .....	6-1
Table 6-2. Port Configuration Screen Controls .....	6-6
Table 6-3. Port Statistics Screen Controls .....	6-8
Table 6-4. Port Mirroring Screen Controls .....	6-15
Table 6-5. QoS Setting Screen Controls .....	6-17
Table 6-6. Storm Control Screen Controls .....	6-19
Table 6-7. Comparison of Port States .....	6-22
Table 6-8. IGMP Snooping Screen Controls .....	6-30
Table 6-9. Uplink Failure Tracking Configuration Screen Controls .....	6-32
Table 7-1. Home Page Controls and Components .....	7-4
Table 7-2. System Information Page Parameters .....	7-10
Table 7-3. Management Security Basic Settings Page Parameters .....	7-17
Table 7-4. Radius Server Configuration Page Parameters .....	7-18
Table 7-5. TACACS+ Global Settings Page Parameters .....	7-19
Table 7-6. TACACS+ Server Configuration Page Parameters .....	7-20
Table 7-7. IP Authorized Manager Page Parameters .....	7-21
Table 7-8. SSH Configuration Page Parameters .....	7-22
Table 7-9. Syslog Configuration Page Parameters .....	7-25
Table 7-10. Syslog Mail Configuration Page Parameters .....	7-26
Table 7-11. MAC ACL Configuration Page Parameters .....	7-27
Table 7-12. IP Standard ACL Configuration Page Parameters .....	7-29
Table 7-13. IP Extended ACL Configuration Page Parameters .....	7-30
Table 7-14. Web GUI Settings Page Parameters .....	7-31
Table 7-15. SNMP Agent Configuration Pages .....	7-32
Table 7-16. SNMP Community Settings Page Parameters .....	7-33
Table 7-17. SNMP Group Settings Page Parameters .....	7-34
Table 7-18. SNMP Group Access Settings Page Parameters .....	7-35
Table 7-19. SNMP View Tree Settings Page Parameters .....	7-37
Table 7-20. SNMP Target Address Settings Page Parameters .....	7-37

---

Table 7-21. SNMP Target Parameter Settings Page Parameters .....	7-39
Table 7-22. SNMP Security Settings Page Parameters.....	7-40
Table 7-23. SNMP Trap Settings Page Parameters .....	7-41
Table 7-24. SNMP AgentX Subagent Settings Page Parameters .....	7-41
Table 7-25. Event Configuration Page Parameters .....	7-44
Table 7-26. RMON Alarm Configuration Page Parameters .....	7-45
Table 7-27. Ethernet Statistics Configuration Page Parameters.....	7-46
Table 7-28. History Control Configuration Page Parameters.....	7-47
Table 7-29. QOS Basic Settings Page Parameters .....	7-49
Table 7-30. QOS Classmap Settings Page Parameters .....	7-49
Table 7-31. QOS Policymap Settings Page Parameters .....	7-50
Table 7-32. COSQ Scheduling Algorithm Settings Page Parameters .....	7-51
Table 7-33. COSQ Weight and Bandwidth Configurations Page Parameters.....	7-52
Table 7-34. NTP Settings Page Parameters.....	7-53
Table 7-35. Stack Configuration Page Parameters.....	7-59
Table 7-36. Stack Details Page Parameters .....	7-60
Table 7-37. Stack Counter Details Page Parameters .....	7-62
Table 7-38. Port Basic Settings Page Parameters.....	7-67
Table 7-39. Port Monitoring Page Parameters.....	7-68
Table 7-40. VLAN Traffic Class Mapping Page Parameters.....	7-69
Table 7-41. Port Control Page Parameters.....	7-70
Table 7-42. Rate Limiting Page Parameters .....	7-71
Table 7-43. VLAN Basic Settings Page Parameters.....	7-73
Table 7-44. VLAN Port MAC Map Page Parameters .....	7-76
Table 7-45. VLAN Unicast Mac Settings Page Parameters.....	7-77
Table 7-46. Wildcard Settings Page Parameters .....	7-78
Table 7-47. SwitchPort Vlan Filtering Page Parameters.....	7-79
Table 7-48. Dynamic VLAN Port Configuration Page Parameters.....	7-81
Table 7-49. Garp Timers Configuration Page Parameters.....	7-82
Table 7-50. Global Configuration Page Parameters .....	7-83
Table 7-51. RSTP Configuration Page Parameters.....	7-84
Table 7-52. Port Status Configuration Page Parameters.....	7-85
Table 7-53. RSTP Port Status Page Parameters.....	7-86
Table 7-54. Global Configuration Page Parameters .....	7-88
Table 7-55. CIST Settings Page Parameters.....	7-90
Table 7-56. VLAN Mapping Page Parameters.....	7-91
Table 7-57. Port Settings Page Parameters .....	7-92
Table 7-58. MSTP CIST Port Status Page Parameters.....	7-93
Table 7-59. LA Basic Settings Page Parameters.....	7-95

---

Table 7-60. Port Channel Interface Basic Settings Page Parameters .....	7-96
Table 7-61. LA Port Channel Settings Page Parameters.....	7-97
Table 7-62. LA Port Settings Page Parameters.....	7-98
Table 7-63. 802.1x Basic Settings Page Parameters .....	7-101
Table 7-64. 802.1x Port Settings Page Parameters.....	7-103
Table 7-65. 802.1x Timer Configuration Page Parameters.....	7-104
Table 7-66. Local Authentication Server Configuration Page Parameters.....	7-105
Table 7-67. MAC Session Info Page Parameters .....	7-106
Table 7-68. L2 Unicast Filter Configuration Page Parameters.....	7-107
Table 7-69. L2 Multicast Filter Configuration Page Parameters .....	7-109
Table 7-70. VLAN Interface Basic Settings Page Parameters.....	7-110
Table 7-71. IPv4 Interface Settings Page Parameters.....	7-111
Table 7-72. IP Route Configuration Page Parameters.....	7-112
Table 7-73. LoopBack Basic Settings Page Parameters .....	7-113
Table 7-74. IP6 Route Configuration Page Parameters.....	7-114
Table 7-75. IPv6 Interface Settings Page Parameters.....	7-115
Table 7-76. ND Cache Configuration Page Parameters .....	7-117
Table 7-77. Address Settings Page Parameters.....	7-117
Table 7-78. Address Profile Settings Page Parameters.....	7-118
Table 7-79. Prefix Configuration Page Parameters .....	7-119
Table 7-80. DHCP Basic Settings Page Parameters.....	7-120
Table 7-81. DHCP Pool Settings Page Parameters.....	7-121
Table 7-82. DHCP Relay Configuration Page Parameters .....	7-122
Table 7-83. DHCP Relay Interface Configuration Page Parameters .....	7-123
Table 7-84. RIP Basic Settings Page Parameters .....	7-124
Table 7-85. RIP Interface Page Parameters .....	7-125
Table 7-86. RIP Security Setting Page Parameters.....	7-127
Table 7-87. RIP Interface Specific Address Summarization Page Parameters.....	7-128
Table 7-88. RIP6 Interface Configuration Page Parameters.....	7-129
Table 7-89. RIP6 Filter Configuration Page Parameters.....	7-131
Table 7-90. OSPF Basic Settings Page Parameters .....	7-132
Table 7-91. OSPF Area Configuration Page Parameters .....	7-133
Table 7-92. OSPF Interface Configuration Page Parameters.....	7-134
Table 7-93. OSPF Virtual Interface Configuration Page Parameters.....	7-135
Table 7-94. OSPF Neighbor Configuration Page Parameters .....	7-136
Table 7-95. OSPF RRD Route Configuration Page Parameters .....	7-137
Table 7-96. OSPF Area Aggregation Page Parameters .....	7-138
Table 7-97. OSPF As External Aggregation Configuration Page Parameters.....	7-139

---

Table 7-98. OSPFv3 Basic Settings Page Parameters.....	7-141
Table 7-99. Interface Settings Page Parameters .....	7-143
Table 7-100. OSPFv3 Area Settings Page Parameters.....	7-144
Table 7-101. OSPF AS External Aggregation Configuration Page Parameters.....	7-145
Table 7-102. BGP Basic Settings Page Parameters.....	7-148
Table 7-103. BGP Peer Configuration Page Parameters .....	7-149
Table 7-104. BGP MED Configuration Page Parameters .....	7-150
Table 7-105. BGP Local Preference Configuration Page Parameters.....	7-151
Table 7-106. BGP Filter Configuration Page Parameters .....	7-152
Table 7-107. BGP Route Aggregation Configuration Page Parameters .....	7-153
Table 7-108. Advanced BGP Configuration Page Parameters .....	7-154
Table 7-109. BGP Community Management Page Parameters .....	7-156
Table 7-110. RRD Basic Settings Page Parameters .....	7-157
Table 7-111. RRD BGP Configuration Page Parameters .....	7-158
Table 7-112. RRD RIP Configuration Page Parameters.....	7-159
Table 7-113. RRD OSPF Configuration Page Parameters .....	7-160
Table 7-114. RRD6 Filter Configuration Page Parameters.....	7-162
Table 7-115. RRD6 OSPFv3 Configuration Page Parameters .....	7-163
Table 7-116. RRD RIPv6 Configuration Page Parameters .....	7-164
Table 7-117. VRRP Settings Page Parameters .....	7-166
Table 7-118. IGMP Snooping Configuration Page Parameters .....	7-168
Table 7-119. IGMP Snooping Timer Configuration Page Parameters.....	7-169
Table 7-120. IGMP Snooping Interface Configuration Page Parameters.....	7-170
Table 7-121. IGMP Snooping VLAN Router Ports Page Parameters.....	7-172
Table 7-122. MAC Based Multicast Forwarding Table Page Parameters.....	7-172
Table 7-123. Dynamic Multicast Port Configuration Page Parameters.....	7-174
Table 7-124. IGMP Interface Configuration Page Parameters .....	7-176
Table 7-125. IGMP Group Configuration Page Parameters .....	7-177
Table 7-126. IGMP Source Information Page Parameters .....	7-178
Table 7-127. PIM Basic Settings Page Parameters.....	7-179
Table 7-128. PIM Component Configuration Page Parameters.....	7-180
Table 7-129. PIM Interface Configuration Page Parameters .....	7-181
Table 7-130. Candidate RP Configuration Page Parameters .....	7-182
Table 7-131. PIM Threshold Configuration Page Parameters .....	7-183
Table 7-132. Static RP Configuration Page Parameters.....	7-184
Table 7-133. DVMRP Basic Settings Page Parameters .....	7-185
Table 7-134. DVMRP Interface Settings Page Parameters.....	7-186
Table 7-135. Interface Statistics Page Parameters.....	7-188

---

Table 7-136. Ethernet Statistics Page Parameters .....	7-190
Table 7-137. Radius Server Statistics Page Parameters.....	7-191
Table 7-138. TACACS+ Statistics Page Parameters.....	7-193
Table 7-139. RMON Ethernet Statistics Page Parameters .....	7-195
Table 7-140. SNMP Statistics Page Parameters .....	7-197
Table 7-141. Agentx Subagent Statistics Page Parameters .....	7-198
Table 7-142. VLAN Current Database Page Parameters .....	7-200
Table 7-143. VLAN Port Statistics Page Parameters.....	7-201
Table 7-144. VLAN Multicast Table Page Parameters .....	7-202
Table 7-145. VLAN Counter Statistics Page Parameters .....	7-203
Table 7-146. VLAN Capabilities Page Parameters.....	7-204
Table 7-147. VLAN FDB Entries Page Parameters .....	7-205
Table 7-148. RSTP Information Page Parameters .....	7-206
Table 7-149. RSTP Port Statistics Page Parameters .....	7-207
Table 7-150. MSTP Information Page Parameters.....	7-209
Table 7-151. MSTP CIST Port Statistics Page Parameters.....	7-210
Table 7-152. MSTP MSTI Port Statistics Page Parameters .....	7-212
Table 7-153. LA Port Statistics Page Parameters.....	7-213
Table 7-154. LA Neighbor Statistics Information Page Parameters.....	7-214
Table 7-155. 802.1x Session Statistics Page Parameters.....	7-215
Table 7-156. 802.1x Supplicant Session Statistics Page Parameters .....	7-216
Table 7-157. MAC Session Statistics Page Parameters.....	7-218
Table 7-158. ARP Cache Page Parameters .....	7-219
Table 7-159. ICMP Statistics Page Parameters.....	7-220
Table 7-160. IPV6 Interface Statistics Page Parameters.....	7-222
Table 7-161. ICMPv6 Statistics Page Parameters.....	7-224
Table 7-162. RIP Interface Statistics Page Parameters.....	7-226
Table 7-163. RIP6 Interface Statistics Page Parameters.....	7-227
Table 7-164. RIP6 Route Information Page Parameters .....	7-228
Table 7-165. OSPF Route Information Page Parameters.....	7-230
Table 7-166. OSPF Link State Database Page Parameters.....	7-231
Table 7-167. OSPFV3 Route Information Page Parameters .....	7-233
Table 7-168. OSPFV3 Link State Database Page Parameters .....	7-234
Table 7-169. VRRP Statistics Page Parameters.....	7-235
Table 7-170. IGMP Snooping Clear Statistics Page Parameters.....	7-237
Table 7-171. IGMP Snooping V1/V2 Statistics Page Parameters .....	7-238
Table 7-172. IGMP Snooping V3 Statistics Page Parameters.....	7-239
Table 7-173. IGMP Route Statistics Page Parameters.....	7-240
Table 7-174. PIM Interface Statistics Page Parameters .....	7-242
Table 7-175. PIM Neighbor Statistics Page Parameters.....	7-243

---

---

Table 7-176. PIM BSR Info Page Parameters .....	7-244
Table 7-177. PIM RP Information Page Parameters.....	7-245
Table 7-178. PIM Route Information Page Parameters .....	7-246
Table 7-179. DVMRP Routes Page Parameters.....	7-247
Table 7-180. DVMRP Multicast Routes Page Parameters .....	7-248
Table 7-181. DVMRP Prune Statistics Page Parameters .....	7-249
Table B-1. Gigabit Ethernet Switch LED Indicators .....	B-1
Table B-2. 1/10 Gigabit Ethernet Switch LED Indicators .....	B-2
Table B-3. Stacking LED Activity (SBM-GEM-X2C/+ Only) .....	B-2
Table B-4. SBM-XEM-X10SM Ethernet Switch LEDs.....	B-3
Table B-5. SBM-IBS-001 InfiniBand Switch LEDs .....	B-4
Table B-6. SBM-IBS-Q3616M and SBM-IBS-Q3618M InfiniBand Switch LEDs.....	B-5

## Notes



---

---

# Chapter 1

## Introduction

### 1-1 Overview

The Superblade Network Modules User's Manual contains information on all network modules used for the Supermicro SuperBlade system. This incorporates information on the InfiniBand switch module, all Ethernet switch modules and all pass-through modules for both InfiniBand and Ethernet.

### 1-2 Product Checklist of Typical Components

All modules are shipped alone or with a SuperBlade enclosure when ordered. Aside from packaging, no cables or cords are included.

Please refer to our web site for information on operating systems that have been certified for use with the SuperBlade ([www.supermicro.com/products/superblade/](http://www.supermicro.com/products/superblade/)).

**Note:** For your system to work properly, please follow the links below to download all necessary drivers/utilities and the user's manual for your server.

- Supermicro product manuals: <http://www.supermicro.com/support/manuals/>
- Product drivers and utilities: <ftp://ftp.supermicro.com>
- Product safety information: [http://super-dev/about/policies/safety\\_information.cfm](http://super-dev/about/policies/safety_information.cfm)
- If you have any questions, please contact our support team at: **support@supermicro.com**

**Note:** A complete list of safety warnings is provided on the Supermicro web site at [http://www.supermicro.com/about/policies/safety\\_information.cfm](http://www.supermicro.com/about/policies/safety_information.cfm).

### 1-3 Features

See [Chapter 4: "InfiniBand Modules" on page 4-1](#) for information and features of the InfiniBand modules. See [Chapter 5: "Ethernet Modules" on page 5-1](#) for information on all Ethernet switches and pass-through modules.

## 1-4 Contacting Supermicro

### Headquarters

Address: Super Micro Computer, Inc.  
980 Rock Ave.  
San Jose, CA 95131 U.S.A.

Tel: +1 (408) 503-8000

Fax: +1 (408) 503-8008

Email: [marketing@supermicro.com](mailto:marketing@supermicro.com) (General Information)  
[support@supermicro.com](mailto:support@supermicro.com) (Technical Support)

Web Site: [www.supermicro.com](http://www.supermicro.com)

### Europe

Address: Super Micro Computer B.V.  
Het Sterrenbeeld 28, 5215 ML  
's-Hertogenbosch, The Netherlands

Tel: +31 (0) 73-6400390

Fax: +31 (0) 73-6416525

Web Site: [www.supermicro.nl](http://www.supermicro.nl)

Email: [sales@supermicro.nl](mailto:sales@supermicro.nl) (General Information)  
[support@supermicro.nl](mailto:support@supermicro.nl) (Technical Support)  
[rma@supermicro.nl](mailto:rma@supermicro.nl) (Customer Support)

### Asia-Pacific

Address: Super Micro Computer, Inc.  
3F, No. 150, Jian 1st Rd.  
Zhonghe Dist., New Taipei City 23511  
Taiwan (R.O.C)

Tel: +886-(2) 8226-3990

Fax: +886-(2) 8226-3992

Web Site: [www.supermicro.com.tw](http://www.supermicro.com.tw)

Technical Support:

Email: [support@supermicro.com.tw](mailto:support@supermicro.com.tw)

---

---

# Chapter 2

## Standardized Warning Statements

### 2-1 About Standardized Warning Statements

The following statements are industry standard warnings, provided to warn the user of situations which have the potential for bodily injury. Should you have questions or experience difficulty, contact Supermicro's Technical Support department for assistance. Only certified technicians should attempt to install or configure components.

Read this appendix in its entirety before installing or configuring components in the Supermicro chassis

These warnings may also be found on our web site at [http://www.supermicro.com/about/policies/safety\\_information.cfm](http://www.supermicro.com/about/policies/safety_information.cfm).

#### Warning Definition



##### Warning!

This warning symbol means danger. You are in a situation that could cause bodily injury. Before you work on any equipment, be aware of the hazards involved with electrical circuitry and be familiar with standard practices for preventing accidents.

##### 警告の定義

この警告サインは危険を意味します。

人身事故につながる可能性がありますので、いずれの機器でも動作させる前に、電気回路に含まれる危険性に注意して、標準的な事故防止策に精通して下さい。

此警告符号代表危險。

您正處於可能受到嚴重傷害的工作環境中。在您使用設備開始工作之前，必須充分意識到觸電的危險，並熟練掌握防止事故發生的標準工作程序。請根據每項警告結尾的聲明號碼找到此設備的安全性警告說明的翻譯文本。

此警告符號代表危險。

您正處於可能身體可能會受損傷的工作環境中。在您使用任何設備之前，請注意觸電的危險，並且要熟悉預防事故發生的標準工作程序。請依照每一注意事項後的號碼找到相關的翻譯說明內容。

## Warnung

### WICHTIGE SICHERHEITSHINWEISE

Dieses Warnsymbol bedeutet Gefahr. Sie befinden sich in einer Situation, die zu Verletzungen führen kann. Machen Sie sich vor der Arbeit mit Geräten mit den Gefahren elektrischer Schaltungen und den üblichen Verfahren zur Vorbeugung vor Unfällen vertraut. Suchen Sie mit der am Ende jeder Warnung angegebenen Anweisungsnummer nach der jeweiligen Übersetzung in den übersetzten Sicherheitshinweisen, die zusammen mit diesem Gerät ausgeliefert wurden.

BEWAHREN SIE DIESE HINWEISE GUT AUF.

### INSTRUCCIONES IMPORTANTES DE SEGURIDAD

Este símbolo de aviso indica peligro. Existe riesgo para su integridad física. Antes de manipular cualquier equipo, considere los riesgos de la corriente eléctrica y familiarícese con los procedimientos estándar de prevención de accidentes. Al final de cada advertencia encontrará el número que le ayudará a encontrar el texto traducido en el apartado de traducciones que acompaña a este dispositivo.

GUARDE ESTAS INSTRUCCIONES.

### IMPORTANTES INFORMATIONS DE SÉCURITÉ

Ce symbole d'avertissement indique un danger. Vous vous trouvez dans une situation pouvant entraîner des blessures ou des dommages corporels. Avant de travailler sur un équipement, soyez conscient des dangers liés aux circuits électriques et familiarisez-vous avec les procédures couramment utilisées pour éviter les accidents. Pour prendre connaissance des traductions des avertissements figurant dans les consignes de sécurité traduites qui accompagnent cet appareil, référez-vous au numéro de l'instruction situé à la fin de chaque avertissement.

CONSERVEZ CES INFORMATIONS.

## תקנתן הצהרות אזהרה

הצהרות הבאות הן אזהרות על פי תקני התעשייה, על מנת להזהיר את המשתמש מפני חבלה פיזית אפשרית. במידה ויש שאלות או היתקלות בבעיה כלשהי, יש ליצור קשר עם מחלקת תמיכה טכנית של סופרמיקרו. טכנאים מוסמכים בלבד רשאים להתקין או להגדיר את הרכיבים.

יש לקרוא את הנספח במלואו לפני התקנת או הגדרת הרכיבים במארזי סופרמיקרו.

تحذير! هذا الرمز يعني خطر انك في حالة يمكن أن تتسبب في اصابة جسدية .  
قبل أن تعمل على أي معدات، كن على علم بالمخاطر الناجمة عن الدوائر  
الكهربائية

وكن على دراية بالممارسات الوقائية لمنع وقوع أي حوادث  
استخدم رقم البيان المنصوص في نهاية كل تحذير للعثور ترجمتها

안전을 위한 주의사항

경고!

이 경고 기호는 위험이 있음을 알려 줍니다. 작업자의 신체에 부상을 야기 할 수 있는 상태에 있게 됩니다. 모든 장비에 대한 작업을 수행하기 전에 전기회로와 관련된 위험 요소들을 확인하시고 사전에 사고를 방지할 수 있도록 표준 작업절차를 준수해 주시기 바랍니다.

해당 번역문을 찾기 위해 각 경고의 마지막 부분에 제공된 경고문 번호를 참조하십시오

### **BELANGRIJKE VEILIGHEIDSINSTRUCTIES**

Dit waarschuwings symbool betekent gevaar. U verkeert in een situatie die lichamelijk letsel kan veroorzaken. Voordat u aan enige apparatuur gaat werken, dient u zich bewust te zijn van de bij een elektrische installatie betrokken risico's en dient u op de hoogte te zijn van de standaard procedures om ongelukken te voorkomen. Gebruik de nummers aan het eind van elke waarschuwing om deze te herleiden naar de desbetreffende locatie.

BEWAAR DEZE INSTRUCTIES

### **Installation Instructions**



#### **Warning!**

Read the installation instructions before connecting the system to the power source.

設置手順書

システムを電源に接続する前に、設置手順書をお読み下さい。

警告

将此系统连接电源前，请先阅读安装说明。

警告

將系統與電源連接前，請先閱讀安裝說明。

#### **Warnung**

Vor dem Anschließen des Systems an die Stromquelle die Installationsanweisungen lesen.

#### **¡Advertencia!**

Lea las instrucciones de instalación antes de conectar el sistema a la red de alimentación.

#### **Attention**

Avant de brancher le système sur la source d'alimentation, consulter les directives d'installation.

יש לקרוא את הוראות התקנה לפני חיבור המערכת למקור מתח.

اقرأ إرشادات التركيب قبل توصيل النظام إلى مصدر للطاقة

시스템을 전원에 연결하기 전에 설치 안내를 읽어주십시오.

### Waarschuwing

Raadpleeg de installatie-instructies voordat u het systeem op de voedingsbron aansluit.

### Circuit Breaker



#### Warning!

This product relies on the building's installation for short-circuit (overcurrent) protection. Ensure that the protective device is rated not greater than: 250 V, 20 A.

サーキット・ブレーカー

この製品は、短絡（過電流）保護装置がある建物での設置を前提としています。

保護装置の定格が 250 V、20 A を超えないことを確認下さい。

#### 警告

此产品的短路（过载电流）保护由建筑物的供电系统提供，确保短路保护设备的额定电流不大于 250V, 20A。

#### 警告

此產品的短路（過載電流）保護由建築物的供電系統提供，確保短路保護設備的額定電流不大於 250V, 20A。

### Warnung

Dieses Produkt ist darauf angewiesen, dass im Gebäude ein Kurzschluss- bzw. Überstromschutz installiert ist. Stellen Sie sicher, dass der Nennwert der Schutzvorrichtung nicht mehr als: 250 V, 20 A beträgt.

### ¡Advertencia!

Este equipo utiliza el sistema de protección contra cortocircuitos (o sobrecorrientes) del edificio. Asegúrese de que el dispositivo de protección no sea superior a: 250 V, 20 A.

### Attention

Pour ce qui est de la protection contre les courts-circuits (surtension), ce produit dépend de l'installation électrique du local. Vérifiez que le courant nominal du dispositif de protection n'est pas supérieur à :250 V, 20 A.

מוצר זה מסתמך על הגנה המותקנת במבנים למניעת קצר חשמלי. יש לוודא כי המכשיר המגן מפני הקצר החשמלי הוא לא יותר מ-250 V, 20 A

هذا المنتج يعتمد على معدات الحماية من الدوائر القصيرة التي تم تثبيتها في  
المبنى  
تأكد من أن تقييم الجهاز الوقائي ليس أكثر من: 20A, 250V

경고 !

이 제품은 전원의 단락 (과전류) 방지에 대해서 전적으로 건물의 관련 설비에 의존합니다. 보호장치의 정격이 반드시 250V(볼트), 20A(암페어)를 초과하지 않도록 해야 합니다.

### Waarschuwing

Dit product is afhankelijk van de kortsluitbeveiliging (overspanning) van uw elektrische installatie. Controleer of het beveiligde apparaat niet groter gedimensioneerd is dan 220V, 20A.

### Power Disconnection Warning



#### Warning!

The system must be disconnected from all sources of power and the power cord removed from the power supply module(s) before accessing the chassis interior to install or remove system components.

#### 電源切斷の警告

システムコンポーネントの取り付けまたは取り外しのために、シャーシー内部にアクセスするには、

システムの電源はすべてのソースから切斷され、電源コードは電源モジュールから取り外す必要があります。

#### 警告

在你打开机箱并安装或移除内部器件前，必須將系統完全斷電，並移除電源線。

#### 警告

在您打開機殼安裝或移除內部元件前，必須將系統完全斷電，並移除電源線。

### Warnung

Das System muss von allen Quellen der Energie und vom Netzanschlusskabel getrennt sein, das von den Spg.Versorgungsteilmodulen entfernt wird, bevor es auf den Chassisinnenraum zurückgreift, um Systemsbestandteile anzubringen oder zu entfernen.

### ¡Advertencia!

El sistema debe ser disconnected de todas las fuentes de energía y del cable eléctrico quitado de los módulos de fuente de alimentación antes de tener acceso el interior del chasis para instalar o para quitar componentes de sistema.

### Attention

Le système doit être débranché de toutes les sources de puissance ainsi que de son cordon d'alimentation secteur avant d'accéder à l'intérieur du châssis pour installer ou enlever des composants de système.

## אזהרה מפני ניתוק חשמלי

### !אזהרה!

יש לנתק את המערכת מכל מקורות החשמל ויש להסיר את כבל החשמלי מהספק לפני גישה לחלק הפנימי של המארז לצורך התקנת או הסרת רכיבים.

يجب فصل النظام من جميع مصادر الطاقة وإزالة سلك الكهرباء من وحدة امداد الطاقة قبل

الوصول إلى المناطق الداخلية للهيكल لتثبيت أو إزالة مكونات الجهاز

경고!

시스템에 부품들을 장착하거나 제거하기 위해서는 새시 내부에 접근하기 전에 반드시 전원 공급장치로부터 연결되어있는 모든 전원과 전기코드를 분리해주어야 합니다.

### Waarschuwing

Voordat u toegang neemt tot het binnenwerk van de behuizing voor het installeren of verwijderen van systeem onderdelen, dient u alle spanningsbronnen en alle stroomkabels aangesloten op de voeding(en) van de behuizing te verwijderen.

## Equipment Installation



### Warning!

Only trained and qualified personnel should be allowed to install, replace, or service this equipment.

### 機器の設置

トレーニングを受け認定された人だけがこの装置の設置、交換、またはサービスを許可されています。

### 警告

只有经过培训且具有资格的人员才能进行此设备的安装、更换和维修。

### 警告

只有經過受訓且具資格人員才可安裝、更換與維修此設備。



**Warnung**

Das Installieren, Ersetzen oder Bedienen dieser Ausrüstung sollte nur geschultem, qualifiziertem Personal gestattet werden.

**¡Advertencia!**

Solamente el personal calificado debe instalar, reemplazar o utilizar este equipo.

**Attention**

Il est vivement recommandé de confier l'installation, le remplacement et la maintenance de ces équipements à des personnels qualifiés et expérimentés.

**אזהרה!**

צוות מוסמך בלבד רשאי להתקין, להחליף את הציוד או לתת שירות עבור הציוד.

يجب أن يسمح فقط للموظفين المؤهلين والمدربين لتثبيت واستبدال أو خدمة هذا الجهاز  
경고!

훈련을 받고 공인된 기술자만이 이 장비의 설치, 교체 또는 서비스를 수행할 수 있습니다.

**Waarschuwing**

Deze apparatuur mag alleen worden geïnstalleerd, vervangen of hersteld door geschoold en gekwalificeerd personeel.

**Restricted Area**



**Warning!**

This unit is intended for installation in restricted access areas. A restricted access area can be accessed only through the use of a special tool, lock and key, or other means of security. (This warning does not apply to workstations).

**アクセス制限区域**

このユニットは、アクセス制限区域に設置されることを想定しています。

アクセス制限区域は、特別なツール、鍵と錠前、その他のセキュリティの手段を用いてのみ出入りが可能です。

**警告**

此部件应安装在限制进出的场所，限制进出的场所指只能通过使用特殊工具、锁和钥匙或其它安全手段进出的场所。

**警告**

此裝置僅限安裝於進出管制區域，進出管制區域係指僅能以特殊工具、鎖頭及鑰匙或其他安全方式才能進入的區域。

### Warnung

Diese Einheit ist zur Installation in Bereichen mit beschränktem Zutritt vorgesehen. Der Zutritt zu derartigen Bereichen ist nur mit einem Spezialwerkzeug, Schloss und Schlüssel oder einer sonstigen Sicherheitsvorkehrung möglich.

### ¡Advertencia!

Esta unidad ha sido diseñada para instalación en áreas de acceso restringido. Sólo puede obtenerse acceso a una de estas áreas mediante la utilización de una herramienta especial, cerradura con llave u otro medio de seguridad.

### Attention

Cet appareil doit être installée dans des zones d'accès réservés. L'accès à une zone d'accès réservé n'est possible qu'en utilisant un outil spécial, un mécanisme de verrouillage et une clé, ou tout autre moyen de sécurité.

### אזור עם גישה מוגבלת

#### אזהרה!

יש להתקין את היחידה באזורים שיש בהם הגבלת גישה. הגישה ניתנת בעזרת כלי אבטחה בלבד (מפתח, מנעול וכד').

تم تخصيص هذه الوحدة لت تركيبها في مناطق محظورة .  
يمكن الوصول إلى منطقة محظورة فقط من خلال استخدام أداة خاصة،  
قفل ومفتاح أو أي وسيلة أخرى للأمان

경고!

이 장치는 접근이 제한된 구역에 설치하도록 되어 있습니다. 특수도구, 잠금 장치 및 키, 또는 기타 보안 수단을 통해서만 접근 제한 구역에 들어갈 수 있습니다.

### Waarschuwing

Dit apparaat is bedoeld voor installatie in gebieden met een beperkte toegang. Toegang tot dergelijke gebieden kunnen alleen verkregen worden door gebruik te maken van speciaal gereedschap, slot en sleutel of andere veiligheidsmaatregelen.

## Battery Handling



### Warning!

There is the danger of explosion if the battery is replaced incorrectly. Replace the battery only with the same or equivalent type recommended by the manufacturer. Dispose of used batteries according to the manufacturer's instructions.

### 電池の取り扱い

電池交換が正しく行われなかった場合、破裂の危険性があります。交換する電池はメーカーが推奨する型、または同等のものを使用下さい。使用済電池は製造元の指示に従って処分して下さい。

### 警告

電池更換不當會有爆炸危險。請只使用同類電池或製造商推薦的功能相當的電池更換原有電池。請按製造商的說明處理廢舊電池。

### 警告

電池更換不當會有爆炸危險。請使用製造商建議之相同或功能相當的電池更換原有電池。請按照製造商的說明指示處理廢棄舊電池。

### Warnung

Bei Einsetzen einer falschen Batterie besteht Explosionsgefahr. Ersetzen Sie die Batterie nur durch den gleichen oder vom Hersteller empfohlenen Batterietyp. Entsorgen Sie die benutzten Batterien nach den Anweisungen des Herstellers.

### Attention

Danger d'explosion si la pile n'est pas remplacée correctement. Ne la remplacer que par une pile de type semblable ou équivalent, recommandée par le fabricant. Jeter les piles usagées conformément aux instructions du fabricant.

### ¡Advertencia!

Existe peligro de explosión si la batería se reemplaza de manera incorrecta. Reemplazar la batería exclusivamente con el mismo tipo o el equivalente recomendado por el fabricante. Desechar las baterías gastadas según las instrucciones del fabricante.

### אזהרה!

קיימת סכנת פיצוץ של הסוללה במידה והוחלפה בדרך לא תקינה. יש להחליף את הסוללה בסוג התואם מחברת יצרן מומלצת.

סילוק הסוללות המשומשות יש לבצע לפי הוראות היצרן.

هناك خطر من انفجار في حالة استبدال البطارية بطريقة غير صحيحة فعليك استبدال البطارية

فقط بنفس النوع أو ما يعادلها كما أوصت به الشركة المصنعة تخلص من البطاريات المستعملة وفقا لتعليمات الشركة الصانعة

경고!

배터리가 올바르게 교체되지 않으면 폭발의 위험이 있습니다. 기존 배터리와 동일하거나 제조사에서 권장하는 동등한 종류의 배터리로만 교체해야 합니다. 제조사의 안내에 따라 사용된 배터리를 처리하여 주십시오.

### Waarschuwing

Er is ontplofingsgevaar indien de batterij verkeerd vervangen wordt. Vervang de batterij slechts met hetzelfde of een equivalent type die door de fabrikant aanbevolen wordt. Gebruikte batterijen dienen overeenkomstig fabrieksvoorschriften afgevoerd te worden.

## Redundant Power Supplies



### Warning!

This unit might have more than one power supply connection. All connections must be removed to de-energize the unit.

### 冗長電源裝置

このユニットは複数の電源装置が接続されている場合があります。

ユニットの電源を切るためには、すべての接続を取り外さなければなりません。

### 警告

此部件连接的电源可能不止一个，必须将所有电源断开才能停止给该部件供电。

### 警告

此裝置連接的電源可能不只一個，必須切斷所有電源才能停止對該裝置的供電。

### Warnung

Dieses Gerät kann mehr als eine Stromzufuhr haben. Um sicherzustellen, dass der Einheit kein Strom zugeführt wird, müssen alle Verbindungen entfernt werden.

### ¡Advertencia!

Puede que esta unidad tenga más de una conexión para fuentes de alimentación. Para cortar por completo el suministro de energía, deben desconectarse todas las conexiones.

### Attention

Cette unité peut avoir plus d'une connexion d'alimentation. Pour supprimer toute tension et tout courant électrique de l'unité, toutes les connexions d'alimentation doivent être débranchées.

**אם קיים יותר מספק אחד**

**אזהרה!**

ליחידה יש יותר מחיבור אחד של ספק. יש להסיר את כל החיבורים על מנת לרוקן את היחידה.

قد يكون لهذا الجهاز عدة اتصالات بوحدات امداد الطاقة.  
يجب إزالة كافة الاتصالات لعزل الوحدة عن الكهرباء

경고 !

이 장치에는 한 개 이상의 전원 공급 단자가 연결되어 있을 수 있습니다. 이 장치에 전원을 차단하기 위해서는 모든 연결 단자를 제거해야만 합니다.

### Waarschuwing

Deze eenheid kan meer dan één stroomtoevoeraansluiting bevatten. Alle aansluitingen dienen verwijderd te worden om het apparaat stroomloos te maken

### Backplane Voltage



#### Warning!

Hazardous voltage or energy is present on the backplane when the system is operating. Use caution when servicing.

バックプレーンの電圧

システムの稼働中は危険な電圧または電力が、バックプレーン上にかかっています。

修理するには注意ください。

警告

当系统正在进行时，背板上有很危险的电压或能量，进行维修时务必小心。

警告

當系統正在進行時，背板上有危險的電壓或能量，進行維修時務必小心。

### Warnung

Wenn das System in Betrieb ist, treten auf der Rückwandplatine gefährliche Spannungen oder Energien auf. Vorsicht bei der Wartung.

### ¡Advertencia!

Quando el sistema está en funcionamiento, el voltaje del plano trasero es peligroso. Tenga cuidado cuando lo revise.

### Attention

Lorsque le système est en fonctionnement, des tensions électriques circulent sur le fond de panier. Prendre des précautions lors de la maintenance.

מתח בפנל האחורי

אזהרה !

קיימת סכנת מתח בפנל האחורי בזמן תפעול המערכת. יש להיזהר במהלך העבודה.

هناك خطر من التيار الكهربائي أو الطاقة الموجودة على اللوحة  
عندما يكون النظام يعمل كن حذرا عند خدمة هذا الجهاز

경고 !

시스템이 동작 중일 때 후면판 (Backplane) 에는 위험한 전압이나 에너지가 발생 합니다. 서비스 작업 시 주의하십시오 .

### Waarschuwing

Een gevaarlijke spanning of energie is aanwezig op de backplane wanneer het systeem in gebruik is. Voorzichtigheid is geboden tijdens het onderhoud.

## Comply with Local and National Electrical Codes



### Warning!

Installation of the equipment must comply with local and national electrical codes.

地方および国の電気規格に準拠

機器の取り付けはその地方および国の電気規格に準拠する必要があります。

警告

设备安装必须符合本地与本国电气法规。

警告

設備安裝必須符合本地與本國電氣法規。

### Warnung

Die Installation der Geräte muss den Sicherheitsstandards entsprechen.

### ¡Advertencia!

La instalacion del equipo debe cumplir con las normas de electricidad locales y nacionales.

### Attention

L'équipement doit être installé conformément aux normes électriques nationales et locales.

## תיאום חוקי החשמל הארצי

אזהרה !

התקנת הציוד חייבת להיות תואמת לחוקי החשמל המקומיים והארציים.

تركيب المعدات الكهربائية يجب أن يمتثل للقوانين المحلية والوطنية المتعلقة  
بالكهرباء

경고!

현 지역 및 국가의 전기 규정에 따라 장비를 설치해야 합니다.

### Waarschuwing

Bij installatie van de apparatuur moet worden voldaan aan de lokale en nationale elektriciteitsvoorschriften.

## Product Disposal



### Warning!

Ultimate disposal of this product should be handled according to all national laws and regulations.

### 製品の廃棄

この製品を廃棄処分する場合、国の関係する全ての法律・条例に従い処理する必要があります。

### 警告

本产品的废弃处理应根据所有国家的法律和规章进行。

### 警告

本產品的廢棄處理應根據所有國家的法律和規章進行。

### Warnung

Die Entsorgung dieses Produkts sollte gemäß allen Bestimmungen und Gesetzen des Landes erfolgen.

### ¡Advertencia!

Al deshacerse por completo de este producto debe seguir todas las leyes y reglamentos nacionales.

### Attention

La mise au rebut ou le recyclage de ce produit sont généralement soumis à des lois et/ou directives de respect de l'environnement. Renseignez-vous auprès de l'organisme compétent.

## סילוק המוצר

אזהרה!

סילוק סופי של מוצר זה חייב להיות בהתאם להנחיות וחוקי המדינה.

عند التخلص النهائي من هذا المنتج ينبغي التعامل معه وفقا لجميع القوانين واللوائح الوطنية

경고!

이 제품은 해당 국가의 관련 법규 및 규정에 따라 폐기되어야 합니다.

### Waarschuwing

De uiteindelijke verwijdering van dit product dient te geschieden in overeenstemming met alle nationale wetten en reglementen.

### Hot Swap Fan Warning



#### Warning!

The fans might still be turning when you remove the fan assembly from the chassis. Keep fingers, screwdrivers, and other objects away from the openings in the fan assembly's housing.

#### ファン・ホットスワップの警告

シャーシから冷却ファン装置を取り外した際、ファンがまだ回転している可能性があります。ファンの開口部に、指、ドライバー、およびその他のものを近づけないで下さい。

#### 警告

当您从机架移除风扇装置，风扇可能仍在转动。小心不要将手指、螺丝起子和其他物品太靠近风扇。

#### 警告

當您從機架移除風扇裝置，風扇可能仍在轉動。小心不要將手指、螺絲起子和其他物品太靠近風扇。

#### Warnung

Die Lüfter drehen sich u. U. noch, wenn die Lüfterbaugruppe aus dem Chassis genommen wird. Halten Sie Finger, Schraubendreher und andere Gegenstände von den Öffnungen des Lüftergehäuses entfernt.

#### ¡Advertencia!

Los ventiladores podran dar vuelta cuando usted quite ell montaje del ventilador del chasis. Mandtenga los dedos, los destornilladores y todos los objetos lejos de las aberturas del ventilador

#### Attention

Il est possible que les ventilateurs soient toujours en rotation lorsque vous retirerez le bloc ventilateur du châssis. Prenez garde à ce que doigts, tournevis et autres objets soient éloignés du logement du bloc ventilateur.

! אזהרה

כאשר מסירים את חלקי המאוורר מהמארו, יתכן והמאווררים עדיין עובדים. יש להרחיק למרחק בטוח את האצבעות וכלי עבודה שונים מהפתחים בתוך המאוורר



من الممكن أن المراوح لا تزال تدور عند إزالة كتلة المروحة من الهيكل يجب إبقاء الأصابع ومفكات البراغي وغيرها من الأشياء بعيدا عن الفتحات في كتلة المروحة.

경고 !

새시로부터 팬 조립품을 제거할 때 팬은 여전히 회전하고 있을 수 있습니다. 팬 조립품 외관의 열려있는 부분들로부터 손가락 및 스크류드라이버, 다른 물체들이 가까이 하지 않도록 배치해 주십시오.

### Waarschuwing

Het is mogelijk dat de ventilator nog draait tijdens het verwijderen van het ventilatorsamenstel uit het chassis. Houd uw vingers, schroevendraaiers en eventuele andere voorwerpen uit de buurt van de openingen in de ventilatorbehuizing.

## Power Cable and AC Adapter



### Warning!

When installing the product, use the provided or designated connection cables, power cables and AC adaptors. Using any other cables and adaptors could cause a malfunction or a fire. Electrical Appliance and Material Safety Law prohibits the use of UL or CSA -certified cables (that have UL/CSA shown on the code) for any other electrical devices than products designated by Supermicro only.

### 電源コードと AC アダプター

製品を設置する場合、提供または指定された接続ケーブル、電源コードと AC アダプターを使用下さい。他のケーブルやアダプタを使用すると故障や火災の原因になることがあります。電気用品安全法は、UL または CSA 認定のケーブル (UL/CSE マークがコードに表記) を Supermicro が指定する製品以外に使用することを禁止しています。

### 警告

安装此产品时,请使用本身提供的或指定的连接线,电源线和电源适配器.使用其它线材或适配器可能会引起故障或火灾。除了 Supermicro 所指定的产品,电气用品和材料安全法律规定禁止使用未经 UL 或 CSA 认证的线材。(线材上会显示 UL/CSA 符号)。

### 警告

安裝此產品時,請使用本身提供的或指定的連接線,電源線和電源適配器.使用其它線材或適配器可能會引起故障或火災。除了 Supermicro 所指定的產品,電氣用品和材料安全法律規定禁止使用未經 UL 或 CSA 認證的線材。(線材上會顯示 UL/CSA 符號)。

## Warnung

Bei der Installation des Produkts, die zur Verfügung gestellten oder benannt Anschlusskabel, Stromkabel und Netzteile. Verwendung anderer Kabel und Adapter kann zu einer Fehlfunktion oder ein Brand entstehen. Elektrische Geräte und Material Safety Law verbietet die Verwendung von UL-oder CSA-zertifizierte Kabel, UL oder CSA auf der Code für alle anderen elektrischen Geräte als Produkte von Supermicro nur bezeichnet gezeigt haben.

## ¡Advertencia!

Al instalar el producto, utilice los cables de conexión previstos o designados, los cables y adaptadores de CA. La utilización de otros cables y adaptadores podría ocasionar un mal funcionamiento o un incendio. Aparatos Eléctricos y la Ley de Seguridad del Material prohíbe el uso de UL o CSA cables certificados que tienen UL o CSA se muestra en el código de otros dispositivos eléctricos que los productos designados por Supermicro solamente.

## Attention

Lors de l'installation du produit, utilisez les bables de connection fournis ou désigné. L'utilisation d'autres cables et adaptateurs peut provoquer un dysfonctionnement ou un incendie. Appareils électroménagers et de loi sur la sécurité Matériel interdit l'utilisation de UL ou CSA câbles certifiés qui ont UL ou CSA indiqué sur le code pour tous les autres appareils électriques que les produits désignés par Supermicro seulement.

## חשמליים ומתאמי AC

אזהרה!

כאשר מתקינים את המוצר, יש להשתמש בכבלים, ספקים ומתאמים AC אשר נועדו וסופקו לשם כך. שימוש בכל כבל או מתאם אחר יכול לגרום לתקלה או קצר חשמלי. על פי חוקי שימוש במכשירי חשמל וחוקי בטיחות, קיים איסור להשתמש בכבלים המוסמכים ב- UL או ב- CSA (כשאר מופיע עליהם קוד של UL/CSA) עבור כל מוצר חשמלי אחר שלא צוין על ידי סופרקמיקרו בלבד.

عند تركيب الجهاز يجب استخدام كابلات التوصيل، والكابلات الكهربائية ومحولات التيار المتردد التي . أن استخدام أي كابلات ومحولات أخرى يتسبب في حدوث عطل أو حريق. تم توفيرها لك مع المنتج الأجهزة الكهربائية ومواد قانون السلامة يحظر استخدام الكابلات UL أو CSA معتمدة من قبل لأي أجهزة كهربائية أخرى غير المنتجات المعينة من قبل Supermicro (التي تحمل علامة UL/CSA)

경고!

제품을 설치할 때에는 제공되거나 지정된 연결케이블과 전원케이블, AC 어댑터를 사용해야 합니다. 그 밖의 다른 케이블들이나 어댑터들은 고장 또는 화재의 원인이 될 수 있습니다. 전기용품안전법 (Electrical Appliance and Material Safety Law) 은 슈퍼마이크로에서 지정한 제품들 외에는 그 밖의 다른 전기 장치들을 위한 UL 또는 CSA 에서 인증한 케이블 (전선 위에 UL/CSA 가 표시) 들의 사용을 금지합니다.

**Waarschuwing**

Bij het installeren van het product, gebruik de meegeleverde of aangewezen kabels, stroomkabels en adapters. Het gebruik van andere kabels en adapters kan leiden tot een storing of een brand. Elektrisch apparaat en veiligheidsinformatiebladen wet verbiedt het gebruik van UL of CSA gecertificeerde kabels die UL of CSA die op de code voor andere elektrische apparaten dan de producten die door Supermicro alleen.

## Notes

---

---

# Chapter 3

## Setup and Installation

This chapter covers the setup and installation of the SuperBladeSuperBlade Ethernet switch modules.

SuperMicro has three different Gigabit Ethernet switch modules for its SuperBlade system. The first is the SBM-GEM-001 Gigabit Ethernet switch module with ten external 1-Gbps Ethernet uplinks. The second SBM-GEM-X2C(+) and third SBM-GEM-X3S+ 1/10-Gigabit Ethernet switch modules are a 1-Gbps Ethernet switches with three external 10-Gbps uplink and two/four external 1-Gbps Ethernet uplink ports. Supermicro also offers a 10-Gbps Ethernet switch – the SBM-XEM-X10SM. The following pages contain some installation instructions that are common to both switches.



**NOTE:** The pass-through modules do not require any special setup or configuration, just installation in their bays.

The SBM-GEM-002 Gigabit pass-through module uses the same single bays as the Gigabit Ethernet switch modules, while the SBM-XEM-002/MM 10-Gigabit pass-through and the SBM-XEM-X10SM 10-Gigabit switch modules require a double-wide bay for installation into the SuperBlade enclosure. See the *SuperBlade User's Manual* for details on double-wide bay setup.

### 3-1 Installing/Removing a Switch Module

Follow the procedures below for installing or uninstalling any of the Gigabit Ethernet switch modules into a SuperBlade system.

#### Installing a Switch Module

1. Make sure the cover to the module has been installed before proceeding. Follow the anti-static precautions described in [Chapter 2](#).
2. Remove the dummy cover from the bay you want to place the module in.
3. Place the module's release handle in the open position.
4. Slide the module into the module bay until it stops (see [Figure 3-1](#) and [Figure 3-2](#)).

**Figure 3-1. Blade Enclosure with 1-Gbps Switch Modules Installed**

**SBM-GEM-001  
Switch**



**SBM-IBS-001 4x DDR InfiniBand Switch Module**

Figure 3-2. Blade Enclosure with 1/10-Gbps Switch Modules Installed

SBM-GEM-X2C(+)  
Switch



SBM-XEM-002M Pass-Through Module

5. Push the release handle to the closed position.



**NOTE:** After the module has been installed and the handle locked, it will turn on and a POST test will run to verify it is working properly. If there are no problems the blue **Init. OK** LED on the module will illuminate and you will see an **OK** under INITIATED in the GbE SWITCH screen of the management software utility.



**NOTE:** If the module is installed in a top bay it must be positioned upside-down.

### Removing a Switch Module

1. Pull out the release handle to the open position.
2. Pull the module out of the bay.
3. Replace immediately with another module or with a dummy module cover to maintain airflow integrity.

## 3-2 Configuring the Switch Module

Figure 3-3. Configuring the Switch Module

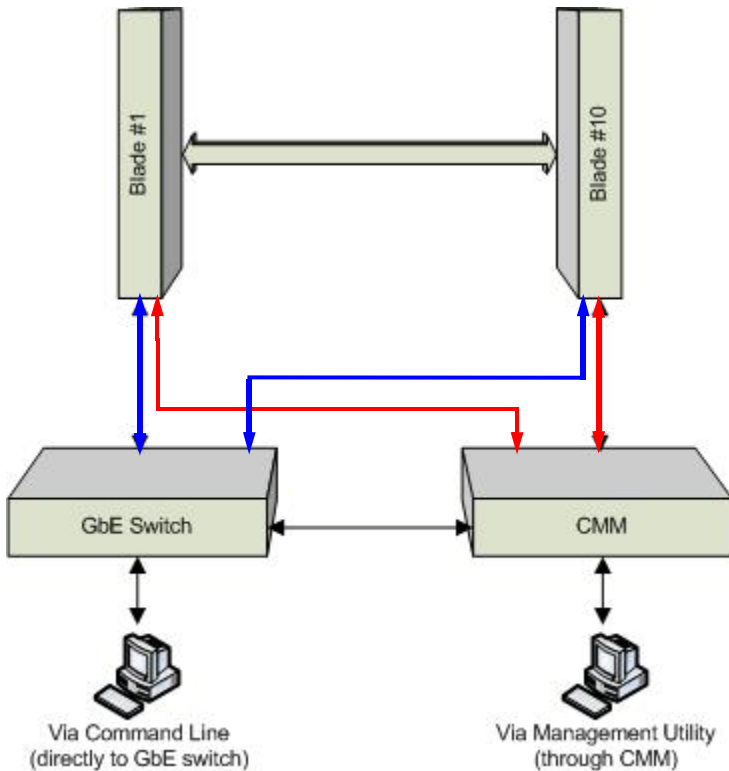

A Gigabit Ethernet switch module can be configured using two methods (as shown in [Figure 3-3](#)). You may configure it:

- Through the web-based management utility or IPMI (via the CMM module)
- Directly through a command line (using a telnet interface or a serial console)

The management utility and IPMI access the switch module through the CMM module. To access it directly, use the command line.

Note that any port may be configured as *up* (active) or *down* (inactive). All ports are active by default.

For more detailed information on configuration of the switches, see either [Chapter 6: "1-Gb Ethernet Switch Firmware" on page 6-1](#) or [Chapter 7: "Layer 2/3 Ethernet Switch Firmware" on page 7-1](#).



## Web-based Management Utility/IPMI

Using the Web-based Management Utility or IPMI is the most user-friendly method of configuring the switch module. You can access the configuration menu either through the management utility or by a network connection.

See either [Chapter 6](#) or [Chapter 7](#) for more details on the Web-based Management Utility.

### Network Connection

Use the procedure below to connect and login to the IPMI system.

#### Logging In to the IPMI:

1. Connect a PC to a network that is accessible to the switch.

For example, connect a PC to any of the front panel ports of the switch and make sure the PC has an IP address on the same subnet as the switch management IP.

2. Type the IP address of the switch that you want to connect to in the address bar of your browser, and hit <ENTER>. Once the connection is made, the LOGIN screen displays ([Figure 3-4](#)).

Figure 3-4. IPMI Login Screen

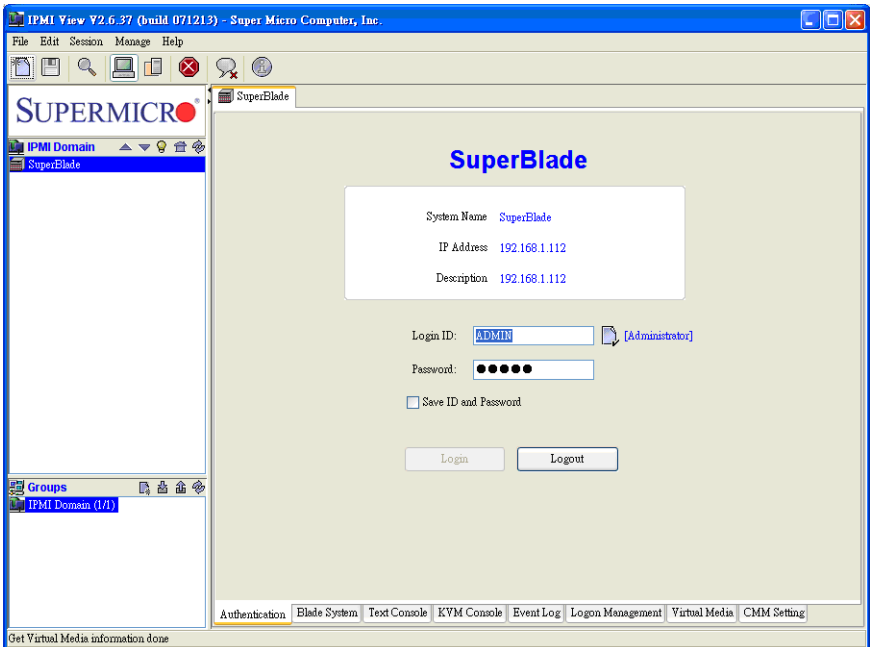

- a. Type in your Username in the USERNAME box.
- b. Type in your Password in the PASSWORD box and click on LOGIN.



**NOTE:** The default username and the default password are both **ADMIN**. The Default IP address is **https://192.168.100.102**.

The IPMI Blade System screen shown in [Figure 3-5](#) is then displayed.

**Figure 3-5. IPMI Blade System Screen**

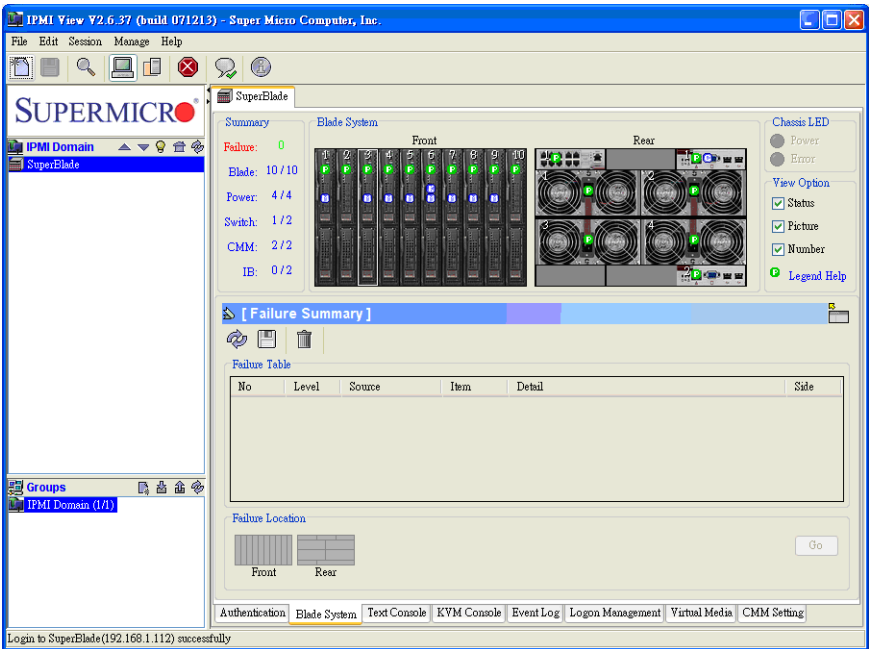

3. Clicking on a gigabit switch module will display the gigabit switch in the Gigabit Switch panel on the screen ([Figure 3-6](#)). You may make changes in the configuration of the switch module in this panel to your needs.

Figure 3-6. Gigabit Switch Panel

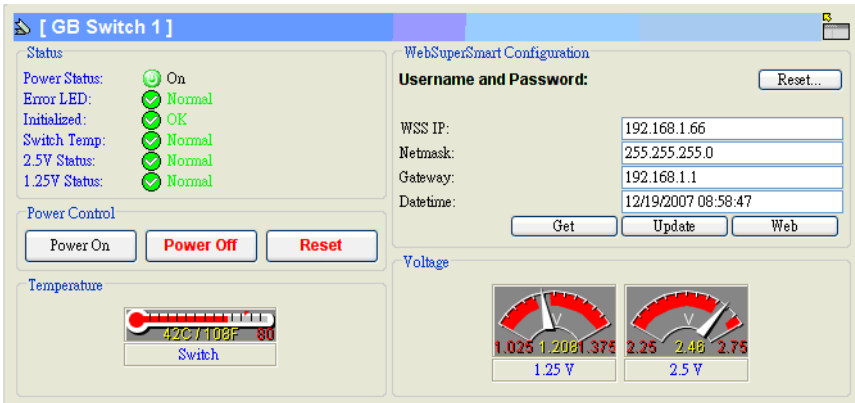

### Address Defaults

The following defaults in [Table 3-1](#) are the default addresses that are initially set. Afterwards, you can change these values within the program.

**Table 3-1. SBM-GEM-001 Switch Module Address Default Settings**

Address	Default Setting
Default IP Address	https://192.168.100.102
Default Gateway Address	192.168.100.1
Default Subnet Mask	255.255.255.0



**NOTE:** If two switches are installed in a SuperBlade system, you will have to change the IP address of one from the default so that both switches have unique addresses.

## Command Line

Configuring the 1/10-G Ethernet switch (SBM-GEM-X2C/SBM-GEM-X3S+) or the 10-G Ethernet switch (SBM-XEM-X10SM) can be done using a command line via telnet or by using the serial console interface.

### **Accessing CLI through Telnet:**

To access command line via telnet, follow the below steps.

1. Connect a PC to a network that is accessible to the switch.  
For example, connect a PC to any of the front panel ports of the switch and make sure the PC has an IP address on the same subnet as the switch management IP.
2. In the PC, start a telnet client session with the switch management IP (default IP is **192.168.100.102**).  
This brings up the switch's command line interface for user login.
3. Enter **username** and **password** to login to the switch.
4. To view the switch configurations use **show commands** and to configure the switch type **config term** to get access to the configuration commands. For help type **?** or **help**.

### **Accessing CLI through a Serial Console**

To access command line via a serial console, follow the below steps.

1. Connect a PC serial port to the switch console port.
2. In the PC, open any serial port access applications, such as Hyperterminal or Term Term.
3. Choose the serial port connected with the switch and configure with the following parameters:  
Baudrate = 9600  
Data bits = 8  
Parity = None  
Stop bit = 1
4. This brings up the switch's command line interface for user login.
5. Enter username and password to login to the switch.
6. To view the switch configurations use **show commands** and to configure the switch type **config term** to get access to the configuration commands. For help type **?** or **help**.

### 3-3 Locating and Identifying Switches and Switch Ports on a Blade Enclosure

Use this section to help you in locating and identifying the switch ports and switches on a blade enclosure.

#### Locating and Identifying a Switch on a Blade Enclosure

When you are looking at the rear of the blade enclosure, you can identify the switch associating with a CMM designation by using the information in [Table 3-2](#).

**Table 3-2. Locating and Identifying a Switch**

Switch Name <sup>a</sup>	SBM-GEM-001/003	SBM-GEM-X2C+/X3S+	SBM-GEP-T20	SBM-XEM-X10SM	SBM-XEM-002M	SBM-IBS All models
Upper Slot	Gigabit Switch 1	L3 Gigabit Switch 1	Gigabit Switch 1	10G Switch 2	10G Switch 2	Infiniband (QDR) Switch 2
Lower Slot	Gigabit Switch 2	L3 Gigabit Switch 2	Gigabit Switch 2	10G Switch 1	10G Switch 1	Infiniband (QDR) Switch 1

a. As shown on the CMM.

#### Locating and Identifying a Switch Port on a Blade Enclosure

In general, a switch that is designated on the CMM as "Switch 1", has its ports electrically routed to the first network interfaces of the blade servers, while the switch designed as "Switch 2" has its ports electrically routed to the second network interfaces of the blade servers. However, pass-through Ethernet modules have a one-to-one relationship between their internal and external ports.

Managed switches have internal ports that are associated with the blade server slots and network interfaces (NIC) as shown in [Table 3-3](#) through [Table 3-7](#).



**NOTE:** Not all switches shown are supported on all blade enclosures. Please check the Superblade matrix for the supported models.

**Table 3-3. SBE-710 Enclosures with SBM-GEM-001/002 or SBM-GEM-X2C+/X3S+**

Blade	Upper Switch	Lower Switch	Switch Port #
Blade1	NIC1	NIC2	Gi 0/1
Blade 2	NIC1	NIC2	Gi 0/2
Blade 3	NIC1	NIC2	Gi 0/3
Blade 4	NIC1	NIC2	Gi 0/4
Blade 5	NIC1	NIC2	Gi 0/5
Blade 6	NIC1	NIC2	Gi 0/6
Blade 7	NIC1	NIC2	Gi 0/7
Blade 8	NIC1	NIC2	Gi 0/8
Blade 9	NIC1	NIC2	Gi 0/9
Blade 10	NIC1	NIC2	Gi 0/10

**Table 3-4. SBE-710 Enclosures with SBM-XEM-X10SM**

Blade	Upper Switch	Lower Switch	Switch Port #
Blade1	NIC2	NIC1	Ex 0/1
Blade 2	NIC2	NIC1	Ex 0/2
Blade 3	NIC2	NIC1	Ex 0/3
Blade 4	NIC2	NIC1	Ex 0/4
Blade 5	NIC2	NIC1	Ex 0/5
Blade 6	NIC2	NIC1	Ex 0/6
Blade 7	NIC2	NIC1	Ex 0/7
Blade 8	NIC2	NIC1	Ex 0/8
Blade 9	NIC2	NIC1	Ex 0/9
Blade 10	NIC2	NIC1	Ex 0/10

**Table 3-5. SBE-720 Enclosures with SBM-GEM-X2C+/X3S+**

Blade	Upper Switch	Lower Switch	Switch Port #
Blade1	NIC1	NIC2	Gi 0/1
Blade 2	NIC1	NIC2	Gi 0/2
Blade 3	NIC1	NIC2	Gi 0/3
Blade 4	NIC1	NIC2	Gi 0/4
Blade 5	NIC1	NIC2	Gi 0/5
Blade 6	NIC1	NIC2	Gi 0/6
Blade 7	NIC1	NIC2	Gi 0/7

**Table 3-5. SBE-720 Enclosures with SBM-GEM-X2C+/X3S+**

<b>Blade</b>	<b>Upper Switch</b>	<b>Lower Switch</b>	<b>Switch Port #</b>
Blade 8	NIC1	NIC2	Gi 0/8
Blade 9	NIC1	NIC2	Gi 0/9
Blade 10	NIC1	NIC2	Gi 0/10
Blade 11	NIC1	NIC2	Gi 0/11
Blade 12	NIC1	NIC2	Gi 0/12
Blade 13	NIC1	NIC2	Gi 0/13
Blade 14	NIC1	NIC2	Gi 0/14
Blade 15	NIC1	NIC2	Gi 0/15
Blade 16	NIC1	NIC2	Gi 0/16
Blade 17	NIC1	NIC2	Gi 0/17
Blade 18	NIC1	NIC2	Gi 0/18
Blade 19	NIC1	NIC2	Gi 0/19
Blade 20	NIC1	NIC2	Gi 0/20

**Table 3-6. SBE-720 Enclosures with SBM-XEM-X10SM**

<b>Blade</b>	<b>Upper Switch</b>	<b>Lower Switch</b>	<b>Switch Port #</b>
Blade1	NIC2	NIC1	Ex 0/1
Blade 2	NIC2	NIC1	Ex 0/2
Blade 3	NIC2	NIC1	Ex 0/3
Blade 4	NIC2	NIC1	Ex 0/4
Blade 5	NIC2	NIC1	Ex 0/5
Blade 6	NIC2	NIC1	Ex 0/6
Blade 7	NIC2	NIC1	Ex 0/7
Blade 8	NIC2	NIC1	Ex 0/8
Blade 9	NIC2	NIC1	Ex 0/9
Blade 10	NIC2	NIC1	Ex 0/10
Blade 11	NIC2	NIC1	Ex 0/11
Blade 12	NIC2	NIC1	Ex 0/12
Blade 13	NIC2	NIC1	Ex 0/13
Blade 14	NIC2	NIC1	Ex 0/14
Blade 15	NIC2	NIC1	Ex 0/15
Blade 16	NIC2	NIC1	Ex 0/16
Blade 17	NIC2	NIC1	Ex 0/17

**Table 3-6. SBE-720 Enclosures with SBM-XEM-X10SM (Continued)**

Blade	Upper Switch	Lower Switch	Switch Port #
Blade 18	NIC2	NIC1	Ex 0/18
Blade 19	NIC2	NIC1	Ex 0/19
Blade 20	NIC2	NIC1	Ex 0/20

**Table 3-7. SBE-714 Enclosures with SBM-GEM-001/002 or SBM-GEM-X2C+/X3S+**

Blade	Upper Switch	Lower Switch	Switch Port #
Blade1	NIC1	NIC2	Gi 0/1
Blade 2	NIC1	NIC2	Gi 0/2
Blade 3	NIC1	NIC2	Gi 0/3
Blade 4	NIC1	NIC2	Gi 0/4
Blade 5	NIC1	NIC2	Gi 0/5
Blade 6	NIC1	NIC2	Gi 0/6
Blade 7	NIC1	NIC2	Gi 0/7
Blade 8	NIC1	NIC2	Gi 0/8
Blade 9	NIC1	NIC2	Gi 0/9
Blade 10	NIC1	NIC2	Gi 0/10
Blade 11	NIC1	NIC2	Gi 0/11
Blade 12	NIC1	NIC2	Gi 0/12
Blade 13	NIC1	NIC2	Gi 0/13
Blade 14	NIC1	NIC2	Gi 0/14



## 3-4 Firmware for the 1/10 Gigabit and 10-Gigabit Ethernet Switch Modules

The firmware for the 1/10-Gigabit and 10-Gigabit Ethernet switch modules resides on a chip on the PCB.

The switch modules have internal flash memory in two areas to hold two firmware images. The flash area used for the normal firmware image is referred to as the *normal* area. The other flash area, referred to as the *fallback* area, is used to store the firmware image for fallback purpose in case of a failure to boot from the normal area.

### Firmware Upgrading Procedures

The procedures for firmware upgrading and using a fallback firmware image are listed below.

#### ***Upgrading Firmware on the Switch using TFTP:***

To upgrade the switch's firmware, use the procedure below.

1. Copy the latest firmware to the TFTP root directory on the TFTP server machine.
2. Make sure the upgraded TFTP server and switch both have network reach ability.
3. Login to the Switch CLI, either through Telnet or a serial console port.
4. Type the below command to upgrade the firmware in the normal area:

```
firmware upgrade tftp://<ip-address>/<filename>  
flash:normal
```

Here *<ip-address>* is the IP address of the TFTP server and *<filename>* is the name of the firmware image file.

5. On successful download CLI displays the below string:

```
Firmware download completed successfully.
```

6. After a successful download, reboot the switch to use this latest firmware.
7. If the download fails, check the IP address, file name, network connections and configurations to reach the TFTP server.
8. If the switch does not come up after the firmware upgrade due to any incorrect firmware images, boot the switch using a fallback firmware image. Refer the steps in the procedure "[Booting using a Fallback Firmware Image:](#)" below to boot the switch using a fallback firmware image.
9. Once the switch is booted with a fallback firmware, repeat the above steps to upgrade with the correct firmware image.
10. On successful upgrade of the latest firmware, it is advised that you upgrade the fallback firmware image also. Follow the steps listed in the procedure "[Upgrading Fallback Firmware using TFTP:](#)" below to upgrade the fallback firmware image.

**Booting using a Fallback Firmware Image:**

Use the procedure below to boot using a fallback firmware image.

1. Reboot the switch by power cycling the switch power.
2. During reboot, press any key when it displays the below text (as shown in [Figure 3-7](#)).

Hit any key to stop autoboot: 5

**Figure 3-7. Displayed Text for Rebooting**

```
Decompressing...OK

Image Running C1ock = 1
Image Running C1ock = 21
system memory informations :
pool size : 25MB
free size : 21MB

PRODUCT TYPE : 24 GE Ports + 4 GE Combo Ports L2 Managed PoE Switch
Hit any key to stop autoboot: 5

ERROR: PCI configuration read(0x0=0xffffffff) -READ ERROR
ERROR: PCI configuration read(0x0=0xffffffff) -READ ERROR
PCI unit 0: Dev0xb313, Rev 0x01, Chip BCM56313_A0, Driver BCM56314_A0
SOC unit 0 attached to PCI device BCM56313_A0
Test chip 0 .....OK

<<< USER MENU >>>

> SYSTEM INFO:
Hardware Version      : B1-01
-----
IP Address           : 192.168.2.32
Subnet Mask          : 255.255.255.0
Default Gateway      : 192.168.2.100
TFTP Server          : 192.168.2.100
Firmware File Name   : SBM-GEM-X2C-v5.2.10.bin

> MENU OPTIONS:
Press [H] to Set Hardware Info
Press [G] to Get Hardware Info
Press [F] to Download Firmware
Press [J] to Jump to Firmware

SMC>
```



**NOTE:** The numbers in the Product Type entry change depending upon the switch you are using.

- Once the boot sequence is interrupted, it will display menu options as shown in [Figure 3-7](#).

Use the "H" option to set hardware information by typing the character **H**. This will display the hardware information that can be changed as shown in [Figure 3-8](#).

**Figure 3-8. Setting Hardware Information**

```
SMC>H
> HARDWARE INFO:
Local IP (p) = 192.168.2.32
Subnet Mask (mask) = 255.255.255.0
Default Gateway (gateway) = 192.168.2.100
TFTP Server (tftpaddr) = 192.168.2.100
Firmware Name (firmdiskname) = SBM-GEM-X2C-v5.2.10.bin
Firmware Flag (flag) = 0

SMC.POSC> rflag=1

> HARDWARE INFO:
Local IP (p) = 192.168.2.32
Subnet Mask (mask) = 255.255.255.0
Default Gateway (gateway) = 192.168.2.100
TFTP Server (tftpaddr) = 192.168.2.100
Firmware Name (firmdiskname) = SBM-GEM-X2C-v5.2.10.bin
Firmware Flag (flag) = 1

SMC.POSC> exit

Save before Exit ? [Y/N] y

Saving Hardware Info ... OK

> HARDWARE INFO:
Local IP (p) = 192.168.2.32
Subnet Mask (mask) = 255.255.255.0
Default Gateway (gateway) = 192.168.2.100
TFTP Server (tftpaddr) = 192.168.2.100
Firmware Name (firmdiskname) = SBM-GEM-X2C-v5.2.10.bin
Firmware Flag (flag) = 1
```

- To choose the boot from a fallback image, type the command: `rflag=1`
- Type `Save` to save the hardware information.
- Type `Exit` to exit the hardware information menu.
- Type **J** to boot the image. In this case it will boot from a fallback image.

8. In case you wish to later move back to a normal image, repeat the above the steps with one difference for [step 4](#), where you should use the command `rflag=0` instead of `rflag=1` to boot with a normal firmware image.

### **Upgrading Fallback Firmware using TFTP:**

To upgrade fallback firmware using TFTP, use the procedure below.

1. Copy the latest firmware to the TFTP root directory on the TFTP server machine.
2. Make sure the upgraded TFTP server and switch both have network reach ability.
3. Login to the Switch CLI either through Telnet or a serial console port.
4. Type the below command to upgrade the firmware in the normal area:

```
firmware upgrade tftp://<ip-address>/<filename> flash:fallback
```

Here *<ip-address>* is the IP address of the TFTP server and *<filename>* is the name of the firmware image file.

5. On a successful download, the CLI displays the below string:

```
Firmware download completed successfully.
```
6. After a successful download, reboot the switch using the fallback image to verify the fallback image. Refer the steps listed above in the procedure "[Booting using a Fallback Firmware Image:](#)" above to boot the switch in the fallback image.
7. Once both the normal and fallback image both have latest firmware, continue to use the normal image as directed in [step 8](#) of the procedure "[Booting using a Fallback Firmware Image:](#)".

## **Firmware Failure Recovery Steps**

In case you have any issues in booting the switch with either a normal or fallback image, use the procedure below to recover the switch functionality with a correctly working firmware image.

### **Recovering Switch Functionality with a Firmware Image:**

1. Copy the latest firmware to the TFTP root directory on a TFTP server machine.
2. Make sure the upgraded TFTP server and switch both have network reach ability.
1. Reboot the switch by power cycling the switch power.
2. During reboot, press any key when it displays the below text (as shown in [Figure 3-7](#)).

```
Hit any key to stop autoboot: 5
```

3. Once the boot sequence is interrupted, it will display menu options as shown in [Figure 3-7](#). Use the "H" option to set hardware information by typing the character H. This will display the hardware information that can be changed as shown in [Figure 3-8](#).

4. Configure the IP address for this switch (only for booting purposes) using the command: `ip=<IP address>`

For example **ip=https://192.168.2.3**

5. Configure the subnet mask for this switch IP address using the below command:

`mask=<subnet mask>`

For example **mask=255.255.255.0**

6. Configure the TFTP server IP address using the below command:

`tftpaddr=<TFTP server IP>`

For example **tftpaddr=192.168.2.100**

7. Configure the gateway address to reach the TFTP server using the below command if the TFTP server is in different network:

`gateway=<gateway IP>`

For example **gateway=192.168.2.100**

8. Configure the firmware image file name using the below command:

`ramdiskname=<filename>`

For example **ramdiskname= SBM-GEM-X2C-v5.2.10.bin**

9. Type `Save` to save the hardware information.
10. Type `Exit` to exit the hardware information menu.
11. Type **F** to download the firmware image. In this case it will download to the normal image area.
12. On a successful download, the switch displays the below string.

```
Updating the ramdisk image ...
This may take awhile
OK
```

13. After a successful download, boot the switch to use this latest firmware by typing **J**.
14. If the download fails, check the IP address, file name, network connections and configurations to reach the TFTP server.

## Notes

---

---

# Chapter 4

## InfiniBand Modules

### 4-1 Overview

InfiniBand is a switch-based, point-to-point bidirectional serial link network communications architecture. Supermicro offers three different Infiniband modules:

- 4X DDR (20-Gb/s) switch with 14 internal ports and 10 external CX4 ports
- 4X DDR (20-Gb/s) pass-through with 14 internal ports and 14 external CX4 ports
- 4X QDR (40-Gb/s) switch with up to 20 internal ports and up to 18 external QSFP ports (4 models).

The main function of the SuperBlade InfiniBand switch modules is to provide high-speed interconnectivity among the blade modules and with external peripherals. These are hot-pluggable modules that must be installed in a double-wide or triple-wide bay at the lower right of the enclosure. Because they occupy one of the bays alternatively used for the CMM, only one InfiniBand module may normally be installed in the system. However, the SBM-IBS-Q3616M and SBM-IBS-Q3618M are exceptions to this since they allow installation of an optional integrated CMM. See [Section 4-4: SBM-IBS-Q3618M/SBM-IBS-Q3616M 4X QDR InfiniBand Switch Modules on page 4-4](#) for details.



**NOTE:** For any blade to access the InfiniBand module, it must first have an InfiniBand card installed on its mainboard. See [Appendix A](#) for details on the Mezzanine HCA cards that are available for use with the InfiniBand module.

## 4-2 SBM-IBS-001 4X DDR InfiniBand Switch Module

Figure 4-1. SBM-IBS-001 InfiniBand Switch Module

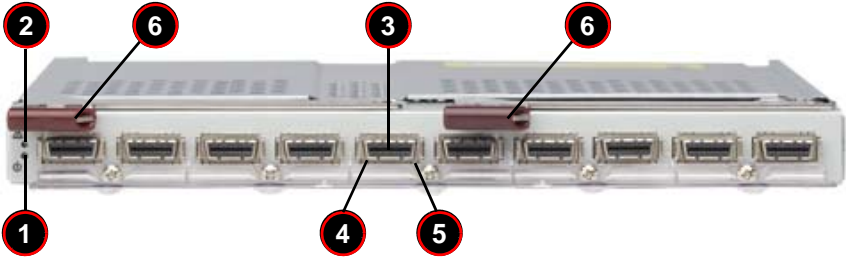

Table 4-1. SBM-IBS-001 InfiniBand Module Interface

Item	Description
1	Module Power LED
2	Module Status LED
3	External InfiniBand Port (10 total)
4	Port Physical Link LED (Green)
5	Port Activity LED (Yellow)
6	Module Release Handle

Table 4-2. SBM-IBS-001 InfiniBand Module Features

Feature	Description
Internal/External Ports	Internal: 14 4X DDR copper ports/ External: 10 4X DDR copper ports
Bandwidth	4X DDR (20-Gbps) non-blocking architecture for 960-Gbps total bandwidth (24-port)
Latency	160 ns port-to-port switch latency
Power Consumption	34 - 40W
Operating System	Firmware (upgradable)



### 4-3 SBM-IBS-Q3618/Q3616 4X QDR InfiniBand Switch Modules

Figure 4-2. SBM-IBS-Q3618/Q3616 InfiniBand Switch Module

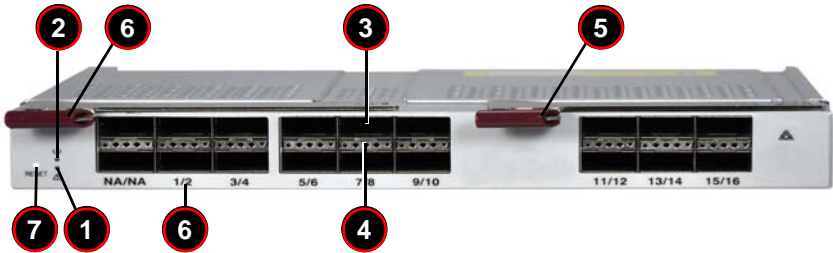

Table 4-3. SBM-IBS-Q3618/Q3616 InfiniBand Module Interface

Item	Description
1	System error. Fault LED (Red) <sup>a</sup>
2	System status. Ready LED (Green) <sup>b</sup>
3	External InfiniBand Port (16 QSFP ports for Q3616 and 18 QSFP ports for Q3618)
4	Per Port Dual-color LED, PHY link(Green)/Logic link(Amber)/ACT blinking(Green+Amber)
5	Module Release Handle
6	Port Numbers (First port number is top port, second port number is bottom port)
7	QDR Switch Reset Button

- If the fault LED goes on, the QDR switch operation is stopped. It then needs a hardware reset or a power off cycle to bring it back into normal operation.
- If the Green LED is blinking, the QDR switch is overheated. Please check the air fan and vent condition. If the fault LED goes on at the same time, a hard reset or a power off cycle needs to be initiated.

Table 4-4. SBM-IBS-Q3618/Q3616 InfiniBand Module Features

Feature	Description
Internal/External Ports	Internal: 18/20 4X QDR copper ports/ External: 18/16 4X QDR copper ports
Bandwidth	4X QDR (40-Gbps) non-blocking architecture for 2.88-Tbps total bandwidth (36-port)
Latency	120-ns port-to-port switch latency
Power Consumption	100W
Operating System	Firmware (upgradable)

## 4-4 SBM-IBS-Q3618M/SBM-IBS-Q3616M 4X QDR InfiniBand Switch Modules

Figure 4-3. SBM-IBS-Q3616M InfiniBand Switch Module

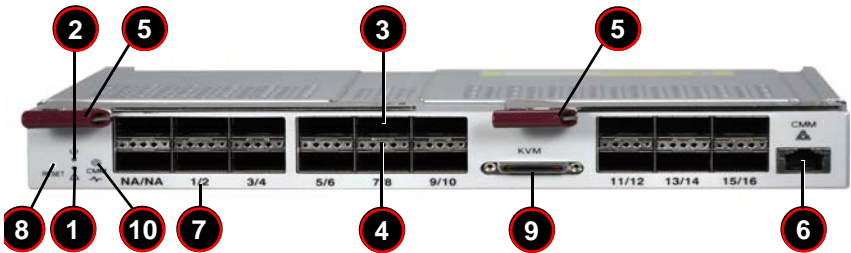

Table 4-5. SBM-IBS-Q3618M/SBM-IBS-Q3616M InfiniBand Module Interface

Item	Description
1	System error. Fault LED (Red) <sup>a</sup>
2	System status. Ready LED (Green) <sup>b</sup>
3	External InfiniBand Ports (16 QSFP ports for Q3616M and 18 QSFP ports for Q3618M)
4	Per Port Dual-color LED, PHY link(Green)/Logic link(Amber)/ACT blinking(Green+Amber)
5	Module Release Handle
6	Internal CMM Module Ethernet Port
7	Port Numbers (First port number is top port, second port number is bottom port)
8	QDR Switch Reset and CMM Load Default
9	KVM Connector
10	CMM Activity LED

- a. If the fault LED goes on, the QDR switch operation is stopped. It then needs a hardware reset or a power off cycle to bring it back into normal operation.
- b. If the Green LED is blinking, the QDR switch is overheated. Please check the air fan and vent condition. If the fault LED goes on at the same time, a hard reset or a power off cycle needs to be initiated.

**Table 4-6. SBM-IBS-Q3618M/SBM-IBS-Q3616M InfiniBand Module Features**

Feature	Description
Internal/External Ports	Internal: 18/20 4X QDR copper ports/ External: 18/16 4X QDR copper ports
Bandwidth	4X QDR (40-Gbps) non-blocking architecture for 2.88-Tbps total bandwidth (36-port)
Latency	120-ns port-to-port switch latency
Power Consumption	120W (with CMM Module Loaded)
Operating System	Firmware (upgradable)

In addition to the InfiniBand switching capability it shares with other Supermicro Blade InfiniBand switches, the SBM-IBS-Q3618M/SBM-IBS-Q3616M modules include provision for the installation of an optional integrated Chassis Management Module (CMM). This “mini-CMM” (BMB-CMM-002) is installed as an add-on-module inside the switch chassis. This allows installation of two (redundant) switches in the SuperBlade enclosure without the loss of system management capability. Note that a dual-port InfiniBand add-on card is required if redundant switches are installed.

Either the RJ45 connector or the KVM connector on the front of the SBM-IBS-Q3618M/SBM-IBS-Q3616M modules can be used to connect to the integrated CMM module (see [Figure 4-3](#)). There is also an activity indicator LED for the CMM on the left-hand side of the front of the SBM-IBS-Q3618M/SBM-IBS-Q3616M modules.

The reset button (lower left), pushed once, will reset the SBM-IBS-Q3618M/SBM-IBS-Q3616M modules. If held down for approximately 5 seconds it will send a signal to the CMM, which cause the CMM to return to default settings.

See Chapter 4, Section 4.1 of the *SuperBlade User’s Manual* for more information on the operation of the CMM itself, including instructions on how to use both the KVM and RJ45 connections.

## 4-5 SBM-IBS-F3616M 4X FDR InfiniBand Switch Module

Figure 4-4. SBM-IBS-F3616M InfiniBand Switch Module

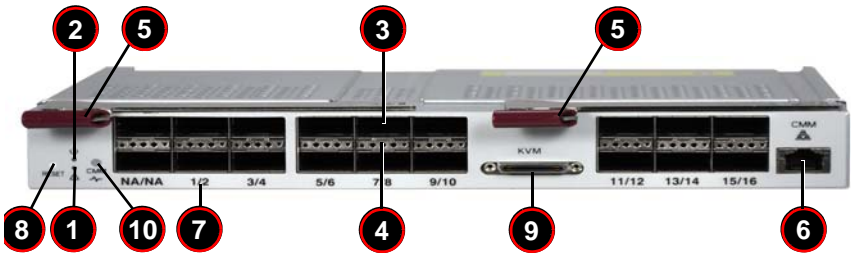

Table 4-7. SBM-IBS-F3616M InfiniBand Module Interface

Item	Description
1	System error. Fault LED (Red) <sup>a</sup>
2	System status. Ready LED (Green) <sup>b</sup>
3	External InfiniBand FDR Ports
4	Per Port Dual-color LED, PHY link(Green)/Logic link(Amber)/ACT blinking(Green+Amber)
5	Module Release Handle
6	Internal CMM Module Ethernet Port
7	Port Numbers (First port number is top port, second port number is bottom port)
8	QDR Switch Reset and CMM Load Default
9	KVM Connector
10	CMM Activity LED

- a. If the fault LED goes on, the FDR switch operation is stopped. It then needs a hardware reset or a power off cycle to bring it back into normal operation.
- b. If the Green LED is blinking, the FDR switch is overheated. Please check the air fan and vent condition. If the fault LED goes on at the same time, a hard reset or a power off cycle needs to be initiated.

**Table 4-8. SBM-IBS-F3616M InfiniBand Module Features**

Feature	Description
Internal/External Ports	Internal: 20 FDR10 ports/ External: 16 4X FDR with QSFP connectors
Bandwidth	4X FDR (56-Gbps) non-blocking architecture with 56Gbps through external ports for 3.392Tbps total switch bandwidth (36-port)
Latency	120-ns port-to-port switch latency
Power Consumption	120W (with CMM Module Loaded)
Operating System	Firmware (upgradable)

In addition to the InfiniBand switching capability it shares with other Supermicro Blade InfiniBand switches, the SBM-IBS-F3616M modules include provision for the installation of an optional integrated Chassis Management Module (CMM). This “mini-CMM” (BMB-CMM-002) is installed as an add-on-module inside the switch chassis. This allows installation of two (redundant) switches in the SuperBlade enclosure without the loss of system management capability. Note that a dual-port InfiniBand add-on card is required if redundant switches are installed.

Either the RJ45 connector or the KVM connector on the front of the SBM-IBS-F3616M modules can be used to connect to the integrated CMM module (see [Figure 4-3](#)). There is also an activity indicator LED for the CMM on the left-hand side of the front of the SBM-IBS-F3616M modules.

The reset button (lower left), pushed once, will reset the SBM-IBS-QF3616M modules. If held down for approximately 5 seconds it will send a signal to the CMM, which cause the CMM to return to default settings.

See Chapter 4, Section 4.1 of the *SuperBlade User's Manual* for more information on the operation of the CMM itself, including instructions on how to use both the KVM and RJ45 connections.

## 4-6 SBM-IBP-D14 InfiniBand Pass-Through Module

Figure 4-5. SBM-IBP-D14 InfiniBand Pass-Through Triple-Wide Module



The SBM-IBP-D14 InfiniBand Pass-through Module is a triple-wide non-configurable pass-through module that includes fourteen (14) 4X DDR copper ports with CX-4 connectors. The pass-through module is used to provide a connection between the InfiniBand controller (Add-on Card) mounted on the blade's mainboard and an external InfiniBand device.

Unlike the SBM-IBS-001 4x DDR InfiniBand switch module, this is a pass-through module. With this module Blade 1 would be connected directly to port 1, Blade 2 to port 2 and so on. If you are only connected to 10 blades then ports 11 through 14 are not connected.

Temperature and voltage of the pass-through module are read through the CMM module. Like other SuperBlade network modules, this pass-through module is hot-pluggable.



**NOTE:** The SBM-IBP-D14 InfiniBand Pass-through Module **must** be connected to another InfiniBand module in order to operate.

## 4-7 Installation and Configuration of InfiniBand Switch Modules

This section covers the installation, removal and configuration of InfiniBand switch modules and InfiniBand pass-through modules.

### Installing/Removing the InfiniBand Switch Module

Before installing the InfiniBand switch module make sure the cover to the module has been installed before proceeding. Refer to the anti-static precautions described in [Chapter 2](#).

The InfiniBand switch module must be installed into a double-wide bay. Assuming that you have already created a double-wide bay out of two single-wide bays, continue with the steps below. See the *SuperBlade User's Manual* for details on setting up double-wide bays in the SuperBlade enclosure.



**NOTE:** The 10GbE Pass-through module (SBM-XEM-002/M) also requires the same double-wide bay as the InfiniBand switch module and may be installed instead of the InfiniBand switch module in your blade enclosure system. Use the same instructions below for installing either the pass-through module or the InfiniBand switch module.

### ***Installing the Module***

1. Remove the dummy cover from the bay you want to place the module in.
2. Place the module's release handle in the open position.
3. Slide the module into the module bay until it stops.
4. Push the release handle to the closed position.

After the module has been installed and the handle locked, it will power on after a short delay and a POST test will run to verify it is working properly.

### ***Removing the Module***

1. Pull out the release handle to the open position.
2. Pull the module out of the bay.
3. Replace immediately with another module or with a dummy module cover to maintain airflow integrity.

## **Installing/Removing the InfiniBand Pass-Through Module**

Before installing the InfiniBand pass-through module make sure the cover to the module has been installed before proceeding. Refer to the anti-static precautions described in [Chapter 2](#).

The InfiniBand pass-through module must be installed into a triple-wide bay. For instructions on how to create a triple-wide bay, see [Appendix C](#).

Assuming that you have already created a triple-wide bay out of three single-wide bays, continue with the steps below.

### ***Installing the Module***

1. Remove the dummy cover from the bay you want to place the module in.
2. Place the module's release handle in the open position.
3. Slide the module into the module bay until it stops.
4. Push the release handle to the closed position.

### ***Removing the Module***

1. Pull out the release handle to the open position.
2. Pull the module out of the bay.
3. Replace immediately with another module or with a dummy module cover to maintain airflow integrity.

## InfiniBand Switch LEDs

InfiniBand switch LEDs are listed and described in [Table B-5](#) in [Appendix B](#).

## Blade Software for Access to InfiniBand Switch Module

The InfiniBand Switch Module is an unmanaged switch and requires no configuration. Blades which are to be connected to it will require an appropriate driver software package to be installed.

The Windows software package (**WinOF**) can be downloaded from:  
[http://www.mellanox.com/content/  
pages.php?pg=products\\_dyn&product\\_family=32&menu\\_section=34](http://www.mellanox.com/content/pages.php?pg=products_dyn&product_family=32&menu_section=34)

The Windows ReadMe is available at:

[http://www.mellanox.com/related-docs/prod\\_software/  
Mellanox\\_WinOF\\_VPI\\_Readme.pdf](http://www.mellanox.com/related-docs/prod_software/Mellanox_WinOF_VPI_Readme.pdf)

Linux OFED software package is available from the following link:

[http://www.mellanox.com/content/  
pages.php?pg=products\\_dyn&product\\_family=26&menu\\_section=34](http://www.mellanox.com/content/pages.php?pg=products_dyn&product_family=26&menu_section=34)

Linux release notes:

[http://www.mellanox.com/related-docs/prod\\_software/  
MLNX\\_OFED\\_1\\_5\\_1\\_release\\_notes.txt](http://www.mellanox.com/related-docs/prod_software/MLNX_OFED_1_5_1_release_notes.txt)



---

---

# Chapter 5

## Ethernet Modules

Your SuperBlade enclosure can include either of several models of Ethernet switch modules or of Ethernet pass-through modules installed in it.

The Ethernet switch modules and pass-through modules can only be installed in the upper and/or lower left module bays, whereas the SBM-XEM-002/M 10-Gigabit pass-through module must be installed in a double-wide slot in the enclosure in a location alternately used for the InfiniBand switch module. The InfiniBand module is discussed in [Chapter 4](#).

### 5-1 SBM-GEM-001 Gigabit Ethernet Switch Module

The SBM-GEM-001 Gigabit Ethernet switch module is a layer 2 Ethernet switch. It includes ten 1-Gb/s uplink (RJ45) ports and fourteen 1-Gb/s downlink ports for the SuperBlade's LAN interfaces. The Gigabit Ethernet switch module has two internal Ethernet paths to the CMM(s). The switch is used to provide a connection between the Ethernet controller integrated on the mainboard and an external Ethernet device. This is a hot-pluggable module. See [Figure 5-1](#), [Table 5-1](#) and [Table 5-2](#) for switch details.

**Figure 5-1. SBM-GEM-001 Gigabit Ethernet Switch Module**

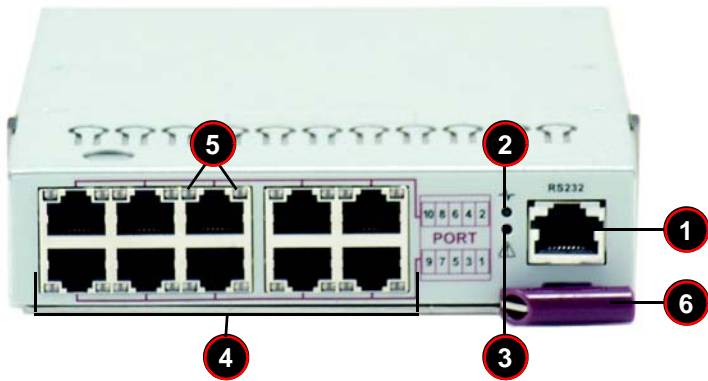

**Table 5-1. SBM-GEM-001 Gigabit Ethernet Switch Module Interface**

Item	Description
1	RS232 (COM) Serial Port
2	"Initiation OK" LED
3	Module Fault LED
4	RJ45 Ethernet Ports

**Table 5-1. SBM-GEM-001 Gigabit Ethernet Switch Module Interface (Continued)**

Item	Description
5	Ethernet Port Status LEDs
6	Module Release Handle

**Table 5-2. GEM-001 Gigabit Ethernet Switch Module Features**

Feature	Description
Chipset	Broadcom BCM5345M
Internal/External Ports	Internal: Fourteen 1-Gbps downlink ports / External: Ten 1-Gbps RJ45 uplink ports
Bandwidth	24-Gbps non-blocking
Trunking	Link aggregation support
Jumbo Frame Support	Up to 9kb
Remote Management	Browser-based management
Protocols	Spanning Tree, Rapid Spanning Tree, Multiple Spanning Tree (802.1d.1w)
Power Consumption	~30.6W
Operating System	Firmware (see <a href="#">Section 3-4: Firmware for the 1/10 Gigabit and 10-Gigabit Ethernet Switch Modules on page 3-13</a> for details)

## LED Indicators

LED indicators for the SBM-GEM-001 Gigabit Ethernet switch module are listed and described in [Table B-1](#) of [Appendix B](#).

## Ports

The SBM-GEM-001 Gigabit Ethernet switch module contains several front-mounted ports as described below in [Table 5-3](#).

**Table 5-3. SBM-GEM-001 Gigabit Ethernet Switch Module Ports**

Port	Description
RS-232 Compatible Serial Port	This port accepts an connector cable for uplink using RS-232 connection to a console.
RJ45 Ethernet Ports	These two ports accept a RJ45 connector for 1-Gbps uplink communications.

## 5-2 SBM-GEM-X2C(+) 1/10-Gb Ethernet Switch Module

The SBM-GEM-X2C(+) 1/10-Gigabit Ethernet switch module is a layer 2/3 Ethernet switch. It includes three 10-Gb/s uplink ports (two CX4 and one SFP+), two 1-Gb/s uplink RJ45 uplink ports and fourteen (X2C) or twenty (X2C+) 1-Gb/s downlink ports for the SuperBlade's LAN interfaces. The Ethernet switch module has two internal Ethernet paths to the CMM(s). The switch is used to provide a connection between the Ethernet controller integrated on the mainboard and an external Ethernet device. This is a hot-pluggable module. See [Figure 5-2](#), [Table 5-4](#) and [Table 5-5](#) for switch details.

**Figure 5-2. SBM-GEM-X2C(+) 1/10-Gigabit Ethernet Switch Module Ports & Indicators**

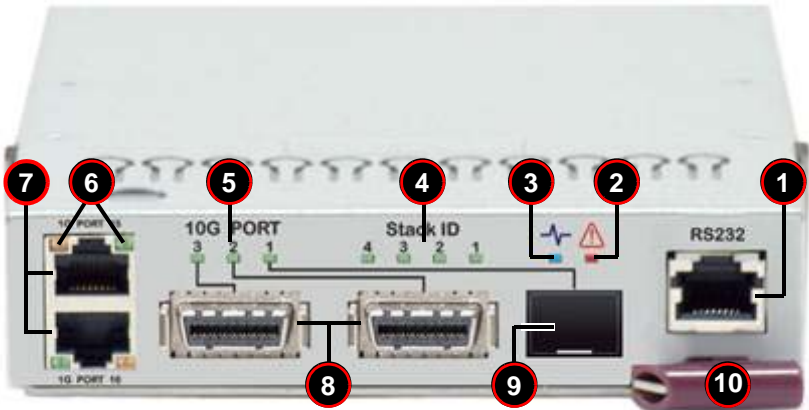

**Table 5-4. SBM-GEM-X2C(+) 1/10-Gigabit Ethernet Switch Module Interface**

Item	Description
1	RS-232 (COM) Serial Port
2	Module Fault LED
3	"Initiation OK" LED
4	Stack ID LEDs (4)
5	10-Gbps Uplink Port Status LEDs (3)
6	1-Gbps RJ45 Uplink Port Status LEDs (Link/Activity and Speed)
7	1-Gbps RJ45 Uplink Ports (2)
8	CX4 10-Gbps Uplink Ports (2)
9	SFP+ 10-Gbps Uplink Port
10	Module Release Handle

**Table 5-5. SBM-GEM-X2C(+)  
1/10-Gigabit Ethernet Switch Module Features**

Feature	Description
Chipset	Broadcom BCM56314
Internal/External Ports	Internal: Twenty (X2C+) 1-Gbps downlink ports External: Two 1-Gbps RJ45 uplink ports and Three 10-Gbps uplink ports (1 SFP+, 2 CX4)
Bandwidth	112-Gbps non-blocking
Trunking	Link aggregation support (Full 802.3 ad)
Jumbo Frame Support	Up to 9KB
Remote Management	Browser-based management or Command Line Interface (CLI)
Protocols	Spanning Tree, Rapid Spanning Tree, Multiple Spanning Tree, IGMP snooping and 802.1x
Power Consumption	~30.6W
Operating System	Firmware (see <a href="#">Section 3-4: Firmware for the 1/10 Gigabit and 10-Gigabit Ethernet Switch Modules on page 3-13</a> for details)

### LED Indicators

LED indicators for the SBM-GEM-X2C(+)  
1/10-Gigabit Ethernet switch module are listed and described in [Table B-2 of Appendix B](#).

### Ports

The SBM-GEM-X2C(+)  
1/10-Gigabit Ethernet switch module contains several front-mounted ports as described below in [Table 5-6](#).

**Table 5-6. SBM-GEM-X2C(+)  
Ports**

Port	Description
RS-232 Compatible Serial Port	This port accepts an connector cable for uplink using RS-232 connection to a console.
RJ45 Ethernet Ports	These two ports accept a RJ45 connector for 1-Gbps uplink communications.
CX4 10-Gbps Ports	These two ports accept a CX4 10GBase-CX4 connectors for 10-Gbps uplink communications or for stacking.
SFP+ 10-Gbps Port	This port accepts a SFP+ Direct Attach connector or fiber with SFP+ transceiver for 10-Gbps uplink communications.

### 5-3 SBM-GEM-X3S+ 1/10-Gb Ethernet Switch Module

The SBM-GEM-X3S+ 1/10-Gigabit Ethernet switch module is a layer 2/3 Ethernet switch. It includes three 10-Gb/s uplink ports (SFP+), four 1-Gb/s uplink RJ45 uplink ports and twenty 1-Gb/s downlink ports for the SuperBlade's LAN interfaces. The Ethernet switch module has two internal Ethernet paths to the CMM(s). The switch is used to provide a connection between the Ethernet controller integrated on the mainboard and an external Ethernet device. This is a hot-pluggable module. See [Figure 5-3](#), [Table 5-7](#) and [Table 5-8](#) for switch details.

**Figure 5-3. SBM-GEM-X3S+ 1/10-Gigabit Ethernet Switch Module Ports & Indicators**

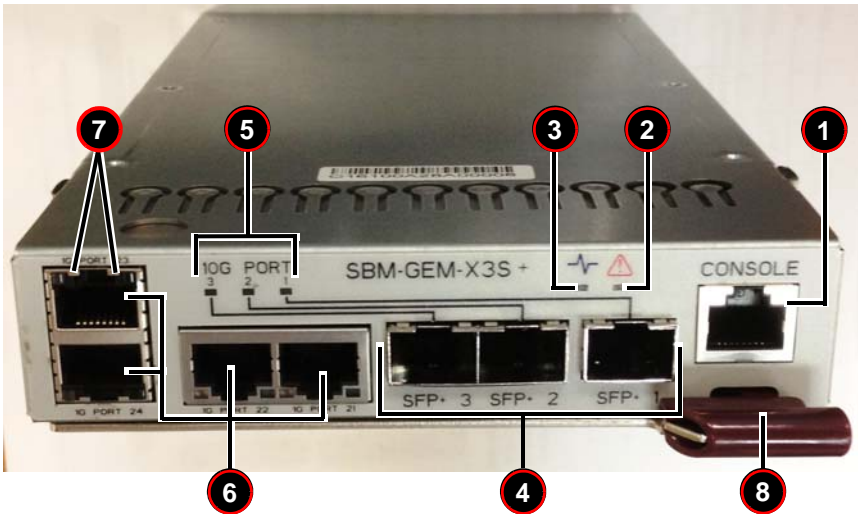

**Table 5-7. SBM-GEM-X3S+ 1/10-Gigabit Ethernet Switch Module Interface**

Item	Description
1	RS-232 (COM) Serial Port
2	Module Fault LED
3	"Initiation OK" LED
4	SFP+ 10-Gbps Uplink Ports
5	10-Gbps Uplink Port Status LEDs (3)
6	1-Gbps RJ45 Uplink Ports (4)
7	1-Gbps RJ45 Uplink Port Status LEDs (Link/Activity and Speed)
8	Module Release Handle

**Table 5-8. SBM-GEM-X3S+ 1/10-Gigabit Ethernet Switch Module Features**

Feature	Description
Chipset	Broadcom BCM56314
Internal/External Ports	Twenty 1-Gbps downlink ports External: Four 1-Gbps RJ45 uplink ports and Three 10-Gbps uplink ports (SFP+)
Bandwidth	104-Gbps non-blocking
Trunking	Link aggregation support (Full 802.3 ad)
Jumbo Frame Support	Up to 9KB
Remote Management	Browser-based management or Command Line Interface (CLI)
Protocols	Spanning Tree, Rapid Spanning Tree, Multiple Spanning Tree, IGMP snooping and 802.1x
Power Consumption	~30.6W
Operating System	Firmware (see <a href="#">Section 3-4: Firmware for the 1/10 Gigabit and 10-Gigabit Ethernet Switch Modules on page 3-13</a> for details)

### LED Indicators

LED indicators for the SBM-GEM-X3S+ 1/10-Gigabit Ethernet switch module are listed and described in [Table B-2](#) of [Appendix B](#).

### Ports

The SBM-GEM-X3S+ 1/10-Gigabit Ethernet switch module contains several front-mounted ports as described below in [Table 5-9](#).

**Table 5-9. SBM-GEM-X3S+ Ports**

Port	Description
RS-232 Compatible Serial Port	This port accepts an connector cable for uplink using RS-232 connection to a console.
RJ45 Ethernet Ports	These four ports accept a RJ45 connector for 1-Gbps uplink communications.
SFP+ 10-Gbps Port	These three ports accept a SFP+ Direct Attach connector or fiber with transceiver for 10-Gbps uplink communications.

## 5-4 SBM-GEM-002 1-Gb Ethernet Pass-through Module

The SBM-GEM-002 Gigabit pass-through module is a non-configurable pass through module that includes fourteen (14) 1-Gb/s uplink (RJ45) ports and fourteen 1-Gb/s downlink ports for the SuperBlade's LAN interfaces. This Ethernet module has two internal Ethernet paths to the CMM(s). The switch is used to provide a connection between the Ethernet controller integrated on the mainboard and an external Ethernet device.

Unlike the SBM-GEM-001 Gigabit Ethernet switch module, this is a pass-through module and is not configurable. With this module Blade 1 would be connected directly to port 1, Blade 2 to port 2 and so on. If you are only connected to 10 blades then ports 11 through 14 are not connected.

Temperature and voltage of the pass-through module are read through the CMM module. The LED's of the pass-through for a blade are only lit when the blade is on. Like the SBM-GEM-001 Gigabit Ethernet switch module, this pass-through module is a hot-pluggable module. See [Figure 5-4](#), [Table 5-10](#) and [Table 5-11](#) for switch details.



**NOTE:** The SBM-GEM-002 Gigabit pass-through module **must** be connected to another Gigabit Ethernet switch module in order to operate. If you connect it to a 10/100 switch, it will not work.

**Figure 5-4. SBM-GEM-002 Gigabit Pass-through Module**

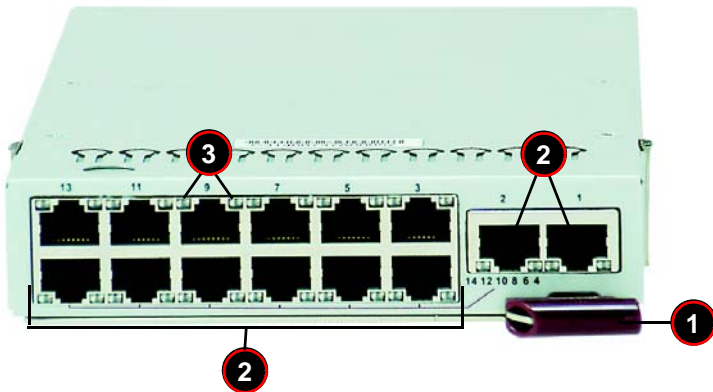

**Table 5-10. SBM-GEM-002 Gigabit Pass-through Module Interface**

Item	Description
1	Module Release Handle
2	RJ45 Ethernet Ports
3	Ethernet Port Status LEDs

**Table 5-11. SBM-GEM-002 Gigabit Ethernet Pass-through Module Features**

Feature	Description
Internal/External Ports	Internal: Fourteen 1-Gbps downlink ports / External: fourteen 1-Gbps RJ45 uplink ports
Remote Management	NA
Protocols	NA
Power Consumption	~30.6W

## 5-5 SBM-XEM-002/M 10-Gb Ethernet Pass-through Module

The SBM-XEM-002/M, and the newer SBM-XEM0-002M 10-Gigabit pass-through modules are non-configurable pass through modules that includes 14 (fourteen) 10-Gb/s uplink (SFP+) ports and 14 10-Gb/s internal downlink (XAUI) ports for the SuperBlade's LAN interfaces.

The SBM-XEM-002/M 10-Gigabit pass-through module includes connectors and circuitry that allow the installation of an optional mini-CMM module (BMB-CMM-002). See the SuperBlade User's Manual for information on the installation and operation of the mini-CMM module. The RJ45 connector is used for console connection to the mini-CMM module.

The SBM-XEM-002/M 10-Gigabit pass-through module must be installed in a double-wide slot in the enclosure. It is installed in a location that is alternately used for the InfiniBand switch module. See the *SuperBlade User's Manual* for details.



**NOTE:** For any blade to access the 10-Gigabit pass-through module, it must first have one of the Connect-X based add-on InfiniBand cards installed on its mainboard (AOC-IBH-XDS or AOC-IBH-XDD, AOC-IBH-XDS, AOC-IBH-XDD or AOC-IBH-XDS or AOC-IBH-XDD cards). See [Appendix A](#) for details on the AOC cards.

Unlike the SBM-GEM-001 or SBM-GEM-X2C(+) Ethernet switch modules, this is a pass-through module, and just like the [SBM-GEM-002 1-Gb Ethernet Pass-through Module](#) model described above, it is not configurable.

With this module Blade 1 would be connected directly to port 1, Blade 2 to port 2 and so on. If you are connected to 10 blades then ports 11 through 14 are not connected.

Temperature and voltage of the pass-through module are read through the CMM module. The LED's of the pass-through for a blade are only lit when the blade is on. Like the other switches, this pass-through module is a hot-pluggable module. See [Figure 5-5](#), [Table 5-12](#) and [Table 5-13](#) for switch details.





**NOTE:** The SBM-XEM-002/M 10-Gigabit pass-through module **must** be connected to another 10-Gigabit Ethernet switch module in order to operate. If you connect it to a 10/100/1000 switch, it will not work.

**Figure 5-5. SBM-XEM-002/M 10-Gigabit Pass-through Module**

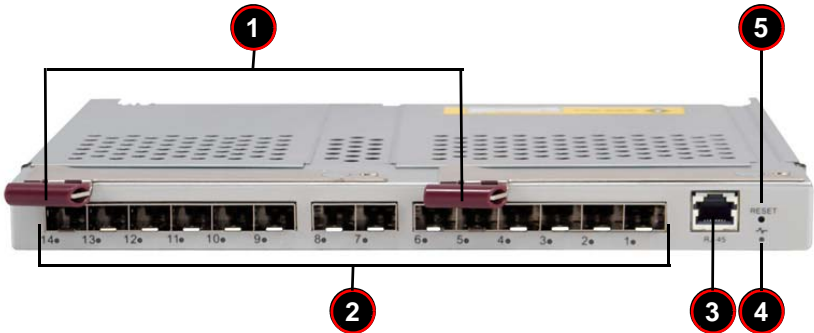

**Table 5-12. SBM-XEM-002/M 10-Gigabit Pass-through Module Interface**

Item	Description
1	Module Release Handles
2	10-Gbp/s Uplink SFP+ Ports
3	RJ45 Ethernet Port for connection to console for mini-CMM
4	"Initiation OK" LED for mini-CMM
5	Reset Button for mini-CMM

**Table 5-13. SBM-XEM-002/M 10-Gigabit Pass-through Module Features**

Feature	Description
Internal/External Ports	Internal: Fourteen 10-Gbps downlink ports to internal 10-Gbps Mezzanine Add-on Card / External: fourteen 10-Gbps SFP+ uplink ports
Remote Management	NA
Protocols	NA
Power Consumption	~30.6W

## 5-6 SBM-GEP-T20 1-Gb Ethernet Pass-through Module for Twin-Blade Modules

The SBM-GEP-T20 Gigabit pass-through module is a non-configurable pass through module that includes twenty (20) 1-Gb/s uplink (RJ45) ports and twenty (20) 1-Gb/s downlink ports for the SuperBlade's LAN interfaces. This Ethernet module has an internal I<sup>2</sup>C path to the CMM. The pass-through module is used to provide a connection between the Ethernet controller integrated on the mainboard and an external Ethernet device.

Unlike the SBM-GEM-001 Gigabit Ethernet switch module, this is a pass-through module and is not configurable. With this module Blade 1 would be connected directly to port 1, Blade 2 to port 2 and so on. If you are only connected to 10 blades then ports 11 through 20 are not connected.

Temperature and voltage of the pass-through module are read through the CMM module. The LED's of the pass-through for a blade are only lit when the blade is on. Like the SBM-GEM-001 Gigabit Ethernet switch module, this pass-through module is a hot-pluggable module. See [Figure 5-6](#), [Table 5-14](#) and [Table 5-15](#) for switch details.



**NOTE:** The SBM-GEP-T20 Gigabit pass-through module **must** be connected to another Gigabit Ethernet switch module in order to operate. If you connect it to a 10/100 switch, it will not work.

Figure 5-6. SBM-GEP-T20 Gigabit Pass-through Module

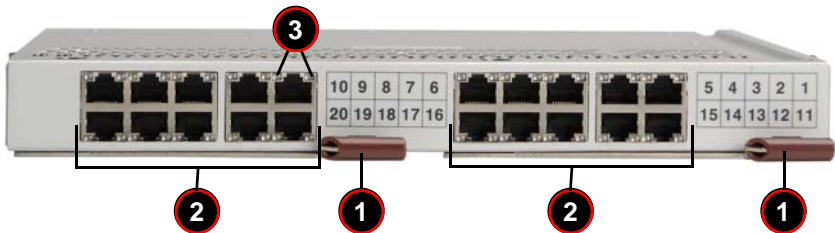

Table 5-14. SBM-GEP-T20 Gigabit Pass-through Module Interface

Item	Description
1	Module Release Handles
2	RJ45 Ethernet Ports
3	Ethernet Port Status LEDs

**Table 5-15. SBM-GEP-T20 Gigabit Ethernet Pass-through Module Features**

Feature	Description
Internal/External Ports	Internal: Twenty 1 Gbps downlink ports / External: twenty 1 Gbps RJ45 uplink ports (fixed speed at 1 Gbps)
Remote Management	NA
Protocols	NA
Power Consumption	~30.6W

The SBM-GEP-T20 is a double-wide module. It installs in the upper left-hand slot in the rear of the SuperBlade enclosure. Only one SBM-GEP-T20 is supported per enclosure (see [Figure 5-7](#)).

**Figure 5-7. SBM-GEP-T20 Installed in Enclosure**

## 5-7 SBM-XEM-X10SM 10-Gb Ethernet Switch Module

The SBM-XEM-X10SM 10-Gigabit Ethernet switch module is a layer 2/3 Ethernet switch. It offers advanced switching features and connection to 10-Gigabit Ethernet networks. Internally it connects to the SuperBlade through a one or two-port mezzanine add-on-card. Externally there are up to ten 10-Gb/s uplink connections (four only that function in the TwinBlade™ system). It also has two internal Ethernet paths to the CMM(s) to allow configuration, management, and control of the switch and its ports through a browser-based management interface. In addition to the Web-based GUI, it offers a CLI for enhanced flexibility in switch management and control. See [Figure 5-8](#), [Table 5-16](#) and [Table 5-17](#) for switch details.

**Figure 5-8. SBM-XEM-X10SM 10 Gigabit Ethernet Switch Module Ports & Indicators**

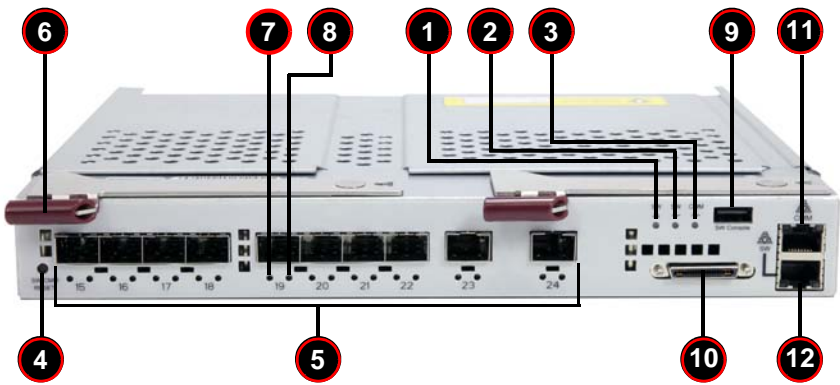

**Table 5-16. SBM-XEM-X10SM 10 Gigabit Ethernet Switch Module Interface**

Item	Description
1	Switch Fault Indicator LED
2	Switch Available Indicator LED
3	CMM Available Indicator LED
4	Reset Button
5	SFP+ 10-Gbps Uplink Ports
6	Module Release Handle
7	10-Gbps Uplink Port Link Up/Available LED
8	10-Gbps Uplink Port Link Activity LED
9	Switch Console USB Port
10	KVM for CMM Port
11	CMM Console RJ45 Port
12	Switch Console RJ45 Port

**Table 5-17. SBM-XEM-X10SM 10 Gigabit Ethernet Switch Module Features**

Feature	Description
Chipset	Broadcom BCM56820
Internal/External Ports	Internal: Twenty 10-Gbps downlink ports External: Four (TwinBlade) or Ten (Ten Blade) 10-Gbps uplink ports (SFP+)
Bandwidth	480-Gbps
Trunking	Link Aggregation Support (Full 802.3 ad)
Jumbo Frame Support	Up to 9KB
Remote Management	Browser-based management or Command Line Interface (CLI)
Protocols	Spanning Tree, Rapid Spanning Tree, Multiple Spanning Tree, IGMP snooping and 802.1x
Power Consumption	
Operating System	Firmware (see <a href="#">Section 3-4: Firmware for the 1/10 Gigabit and 10-Gigabit Ethernet Switch Modules on page 3-13</a> for details)

## LED Indicators

LED indicators for the SBM-XEM-X10SM 10-Gigabit Ethernet switch module are listed and described in [Table B-4](#) of [Appendix B](#).

## Ports

The SBM-XEM-X10SM 10-Gigabit Ethernet switch module contains several front-mounted ports as described below in [Table 5-6](#).

**Table 5-18. SBM-XEM-X10SM Ports**

Port	Description
RS-232 Compatible Serial Port	This port accepts a connector cable for uplink using RS-232 connection to a console.
RJ45 Ethernet Ports	These two ports accept a RJ45 connector for 1-Gbps uplink communications.
USB Port	This port is for a USB connector for switch console communications.
SFP+ 10-Gbps Port	This port accepts a SFP+ Direct Attach connector or fiber with transceiver for 10-Gbps uplink communications.

## 5-8 SBM-XEM-F8X4SM Converged Networking Switch Module

The Supermicro SBM-XEM-F8X4SM converged networking switch module combines 10-Gigabit Ethernet (DCB), Fibre Channel over Ethernet (FCoE) and Fibre Channel (FC) in a single optimized switch. It features a compact design that integrates both 10-GbE Data Center Bridging (DCB) external ports and Fiber Channel external ports for connectivity to both LAN and Storage Area Networks (SANs). It allows you to select a combination of internal and external ports for connectivity to Data Center resources (LAN) and storage including 10GbE, FC and FCoE. This module provides visibility of the VMs in the storage fabric through vHBA capable Supermicro AOC-XEM-iN2 CNA cards, and it provides a high performance low latency architecture supporting a combined 482-Gbps switching bandwidth in full duplex operation. This module provides a rich standard-based features at Layer 2 (Data Link) and Layer 3. Data link layer features include link aggregation to uplink switches, VLANs, QoS, ACLs, IGMP and multicast forwarding. At layer 3, it supports both static and dynamic routing.

See [Figure 5-8](#), [Table 5-16](#) and [Table 5-17](#) for switch details.

Figure 5-9. SBM-XEM-F8X4SM 10 Gigabit Ethernet Switch Module Ports & Indicators

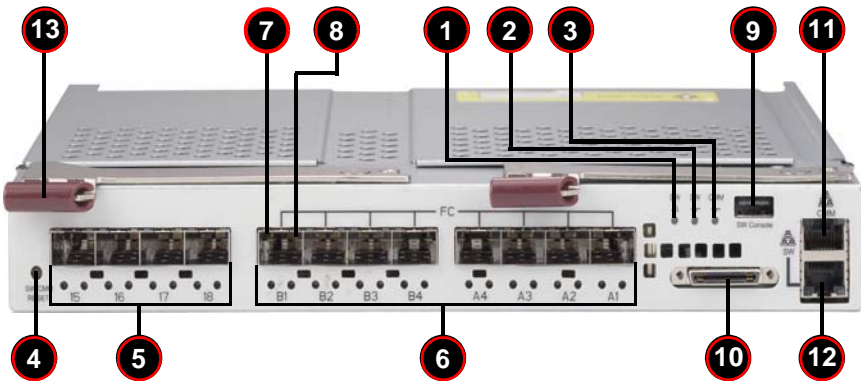

**Table 5-19. SBM-XEM-F8X4SM 10 Gigabit Ethernet Switch Module Interface**

Item	Description
1	Switch Fault Indicator LED
2	Switch Available Indicator LED
3	CMM Available Indicator LED
4	Reset Button
5	SFP+ 10-Gbps Uplink Ports
6	SFP+ Fibre Channel (FC) Uplink Ports
7	10-Gbps Uplink Port Link Up/Available LED
8	10-Gbps Uplink Port Link Activity LED
9	Switch Console USB Port
10	KVM for CMM Port
11	CMM Console RJ45 Port
12	Switch Console RJ45 Port
13	Module Release Handle

**Table 5-20. SBM-XEM-F8X4SM 10 Gigabit Ethernet Switch Module Features**

Feature	Description
Chipset	Broadcom BCM56820
Internal/External Ports	Internal: Ten (10-blade enclosure) or Twenty (TwinBlade enclosure) 10-Gbps downlink ports External: Four (10-blade enclosure) or none (TwinBlade Blade) 10-Gbps uplink ports (SPF+)
Bandwidth	480-Gbps
Trunking	Link Aggregation Support (Full 802.3 ad)
Jumbo Frame Support	Up to 9KB
Remote Management	Browser-based management or Command Line Interface (CLI)
Protocols	Priority-based Flow Control (PFC), Enhanced Transmission Selection (ETS), Data Center Bridging Exchange (DCBX), Spanning Tree, Spanning Tree, Rapid Spanning Tree, Multiple Spanning Tree, LACP (802.3ad), LLDP (802.1AB), Flow Control (802.3x), ACL, Port-based Network Access Control (802.1x), QoS, QoSx, Egress Queuing, Strict priority, Weighted Round Robin (WRR), Weighted Fair Queuing, IGMP snooping (v1 and v2), Support Unicast, Multicast and Broadcast
Power Consumption	124 Watts
Operating System	Firmware (see <a href="#">Section 3-4: Firmware for the 1/10 Gigabit and 10-Gigabit Ethernet Switch Modules on page 3-13</a> for details)

## LED Indicators

LED indicators for the SBM-XEM-F8X4SM 10-Gigabit Ethernet switch module are listed and described in [Table B-4](#) of [Appendix B](#).

## Ports

The SBM-XEM-F8X4SM 10-Gigabit Ethernet switch module contains several front-mounted ports as described below in [Table 5-6](#).

**Table 5-21. SBM-XEM-F8X4SM Ports**

Port	Description
RS-232 Compatible Serial Port	This port accepts a connector cable for uplink using RS-232 connection to a console.
RJ45 Ethernet Ports	These two ports accept a RJ45 connector for 1-Gbps uplink communications.
USB Port	This port is for a USB connector for switch console communications.
SFP+ 10-Gbps Port	This port accepts a SFP+ Direct Attach connector or fiber with transceiver for 10-Gbps uplink communications.



# Chapter 6

## 1-Gb Ethernet Switch Firmware

The firmware configuration system for the SBM-GEM-001 Gigabit Ethernet switch module is covered in this chapter.

### 6-1 SBM-GEM-001 Firmware Features and Functions

Table 6-1 provides a summary of features and functions for the Gigabit Ethernet switch module firmware.

**Table 6-1. SBM-GEM-001 Software Features and Functions**

Item	Functions	Features
Basic Functions	Throughput	24Gbps (14 internal 1-Gbps + 10 external 1-Gbps)
	Latency	Average 2.65usec (frame size 1518 bytes)
	Switching mode	Store-and-forward
	MAC address learning table size	8192 entries
	MAC address learning	IVL (Independent VLAN learning)
	Jumbo frame support	Up to 9216 bytes
	Flow control	802.3x pause frame flow control
	Broadcast Storm Control	Support per-system control types and rates
	Ingress rate control	Support per-port rate control
	Port mirroring	A copy of ingress and egress data of the monitored port is sent to snooping port
Scalability	Trunking (Static Link Aggregation)	Increase bandwidth and redundancy. Up to 8 ports per trunk, 4 trunks per switch.
Redundancy	IEEE802.1D STP IEEE802.1W RSTP	To make a loop-free and redundant network using RSTP. RSTP is upward compatible with legacy STP.
VLAN	IEEE802.1q VLAN	Supports 256 VLAN groups.
QoS	IEEE802.1p QoS	Supports 802.1p priority queuing and 4 priority queues per port.
Multicast	IGMP v1/v2 Snooping	Prevents unnecessary forwarding of multicast packets to reduce multicast traffic.
Management	SNMP agent	Supports SNMP v1 and v2c
	Http server	Forwarding

To configure the switch, select the switch you want in the SWITCH STATUS screen in the Web-based Management Utility. See the *Web-based Management Utility User's Manual* for details.

A SWITCH STATUS screen will appear (Figure 6-1) in your browser.

Figure 6-1. Switch Status Screen



In this screen, either select WEB MANAGEMENT or type the IP address of the switch (usually **192.168.100.102**) in the address field of your web browser. The SYSTEM MANAGEMENT screen shown in Figure 6-2 appears.

Figure 6-2. Switch System Management Screen





**NOTE:** You will see “BMB-GEM-003” on most of these screens. This the board model number for the SBM-GEM-001 switch and is sometimes used interchangeably with it in describing the product.

## 6-1 Port Status

The PORT STATUS screen provides a status overview of the switch's 24 ports. As shown in Figure 6-3, it includes link, speed, duplex, flow control, jumbo frame and PVID. In this screen click on PORT on the left menu bar. The port status will show up. To retrieve and update to the latest status, click the REFRESH button.

Figure 6-3. Port Status Screen

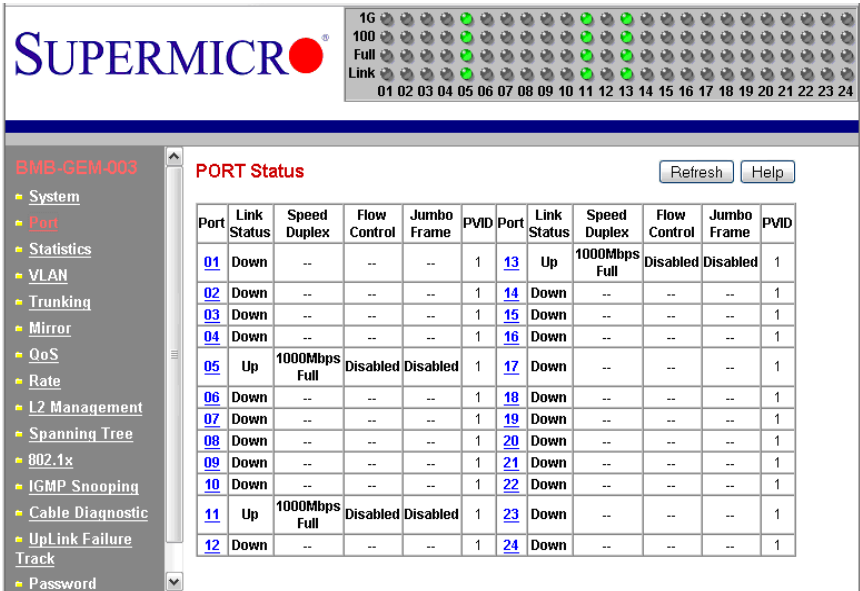

The PORT column indicates the port number of the switch.

The LINK STATUS column shows the current link status (either up or down) for each port.

The SPEED DUPLEX column indicates the link speed and duplex status for each port when it is linked up. If the link is down, there is no status shown on SPEED DUPLEX.

The FLOW CONTROL column indicates that the state of flow control is either disabled or enabled for each port when it is linked up.

The JUMBO FRAMES column indicates that the state of jumbo frame support is either disabled or enabled for each port when it is linked up.

The PVID column shows the current default port VLAN ID for each switch port.



**NOTE:** In the figures BMB-GEM-003 is the number of the Gigabit switch board; it is not a separate model of switch.

## Port VLAN ID (PVID)

The PVID is used in a port-based VLAN to allow assigning a port to belong to a VLAN. A VLAN can then be configured to be a group of member ports. This switch is an 802.1q tag-aware switch. If no VLANs are defined on the switch, every port will be assigned to a default VLAN which has VLAN ID 1. Each port will have PVID equal to 1.

If incoming frames are untagged, they will be tagged with the default PVID of the port on which they are received. The destination MAC address of the frame and the PVID will be used for forwarding decisions. An incoming tagged frame will be kept intact. The switch will use the VID in the frame and the destination MAC address for the forwarding decision. Look for a more detailed description in the VLAN section.

## Jumbo Frames Support

To modify the jumbo frames support for all of ports, click on the EDIT OF JUMBO FRAME setting (as shown in [Figure 6-3](#)) to link to the JUMBO FRAME SETTING screen ([Figure 6-4](#)). Click the ENABLE JUMBO FRAME check box to enable/disable jumbo frame support.

Figure 6-4. Jumbo Frame Setting Screen

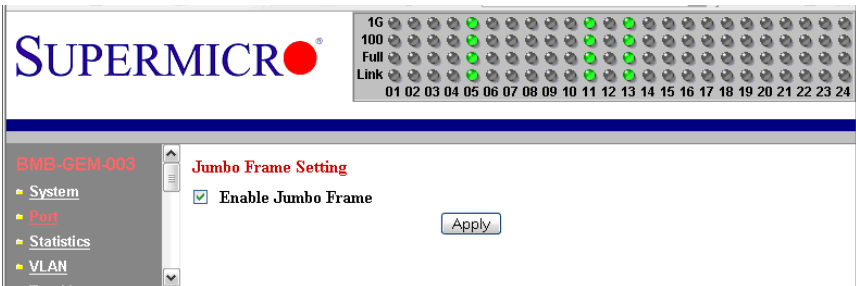

When a jumbo frame is enabled, the maximum length of a frame that can be forwarded by a switch is **9216**. When the jumbo frame is disabled, the maximum length of a frame that can be forwarded by a switch is **1518**.

## Port Configuration

To modify the configuration of each port, click on the port number in the PORT STATUS screen (see [Figure 6-3](#)). The PORT CONFIGURATION screen appears ([Figure 6-5](#)). It is used to define speed and duplexing for a port when auto-negotiation is off. When auto-negotiation is on, this data is negotiated with the link partner.

Figure 6-5. Port Configuration Screen

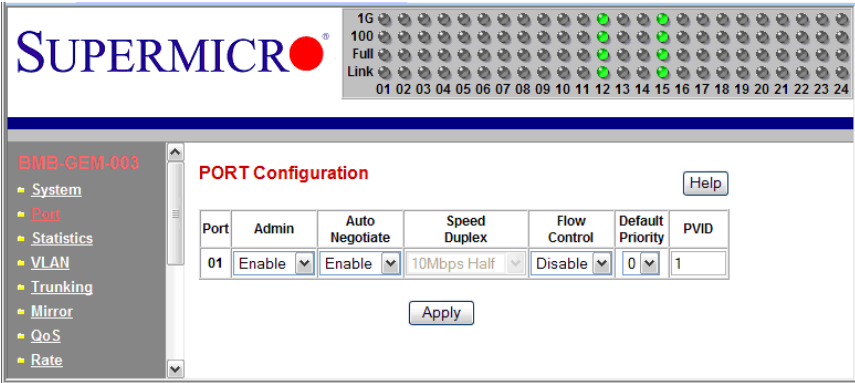

Table 6-2. Port Configuration Screen Controls

Control	Description
Port	Specifies the port number to control.
Admin	Enables or disables the port.
Auto Negotiation	Enables or disables auto-negotiation. When auto-negotiation is enabled, the port negotiates with the link partner and works out speed, duplex operation, and flow control. When auto-negotiation is disabled, port speed, duplex operation, and flow control is programmable by the user.
Duplex Speed	Indicates duplex state and speed of the port.
Flow Control	Turns flow control on or off. When flow control of the port is on, it sends out a Pause frame or a Jam Packet if it is over-subscribed. When this port receives a Pause Frame or Jam Signal, it will postpone sending for a certain period to send out a frame by IEEE definition.
Default Priority	Assigns packet priority for packets arriving at the port without tagging. If the packet comes in with tag or priority-tag, the priority is retrieved from the priority field of the tag.
PVID	Assigns default port VLAN ID for the port. When the port receives a frame which is untagged or priority tagged (VLAN ID = 0), the PVID will be used for forwarding decision for these two kind of frame.

## 6-2 Statistics

The STATISTICS screen displays the total number of packets transmitted or received on each port as shown in [Figure 6-6](#). Click on the REFRESH button to retrieve the current count and update the screen. Click on the CLEAR COUNTERS button to reset the count to zero for each port. Click on each port number to retrieve detail statistic information for that particular port.

Figure 6-6. Statistics Screen

**Statistics**

Port	Tx	Rx	Port	Tx	Rx
<a href="#">01</a>	0	915	<a href="#">13</a>	0	0
<a href="#">02</a>	878	0	<a href="#">14</a>	0	0
<a href="#">03</a>	0	0	<a href="#">15</a>	0	0
<a href="#">04</a>	0	0	<a href="#">16</a>	0	0
<a href="#">05</a>	0	0	<a href="#">17</a>	0	0
<a href="#">06</a>	0	0	<a href="#">18</a>	0	0
<a href="#">07</a>	0	0	<a href="#">19</a>	0	0
<a href="#">08</a>	0	0	<a href="#">20</a>	0	0
<a href="#">09</a>	0	0	<a href="#">21</a>	0	0
<a href="#">10</a>	0	0	<a href="#">22</a>	0	0
<a href="#">11</a>	0	0	<a href="#">23</a>	0	0
<a href="#">12</a>	0	0	<a href="#">24</a>	0	0

(All numbers shown are numbers of packets)

### Port Statistics

The PORT STATISTICS screen ([Figure 6-7](#)) displays detailed traffic statistics for each port to help a user analyze network operations such as traffic bytes, errors, number of packets, etc. These traffic statistics are shown in [Table 6-3](#).

Figure 6-7. Port Statistics Screen

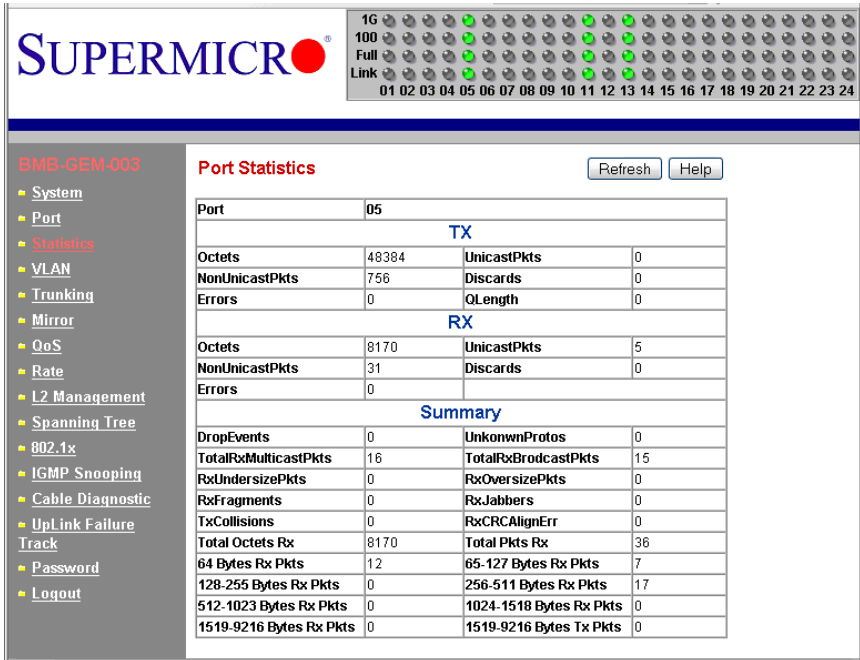

Table 6-3. Port Statistics Screen Controls

Control	Description
TX	Displays traffic information on outgoing frames.
Octets	Indicates total octets transmitted.
UnicastPkts	This indicates transmitted unicast packets.
NonUnicastPkts	This indicates transmitted non-unicast packets.
Discards	This indicates discarded packets.
Errors	This indicates Excessive Collision packets.
QLength	This indicates count of packets currently buffered.
RX	Displays traffic information on incoming frames.
Octets	Indicates total octets received.
UnicastPkts	Indicates received unicast packets.
NonUnicastPkts	Indicates received non-unicast packets.
Discards	Indicates discarded packets.



**Table 6-3. Port Statistics Screen Controls (Continued)**

<b>Control</b>	<b>Description</b>
Errors	Indicates undersize/fragment/FCS error/oversized errors with good FCS packets.
Summary	Displays traffic information by packet type, type of error and frame size range.
DropEvents	Indicates events in which packets are dropped due to a lack of resources. This includes events where the receiving shared buffer is full, and events when a transmission failure is due to a late collision.
UnknownProtos	Indicates received packets using unknown protocols, such as packets that are dropped due to reasons other than drop events and storm limits.
TotalRxMulticastPkts	Indicates the total received multicast packets.
TotalRxBroadcastPkts	Indicates the total received broadcast packets.
RxUndersizePkts	Indicates received packets with a length that is less than the minimum packet size.
RxOversizePkts	Indicates received packets with length more than the maximum packet size.
RxFragments	Indicates received packets (length 10 ~ 63 bytes) with an invalid FCS or an alignment error.
RxJabbers	Indicates received packets (invalid FCS or code error) that exceed the counter maximum size to the maximum received frame length.
TxCollisions	Indicates the total transmitted collision packets.
RxCRCAlignErr	Indicates received packets (invalid FCS) that have a length between 64 bytes and the counter maximum size.
Total Octets Rx	Indicates total number of octets of data received (excluding framing bits, but including FCS bytes).
Total Pkts Rx	Indicates total received packet count (including all bad packets, unicast, broadcast, multicast and MAC control packets).
64 Bytes Rx Pkts	Indicates received packets with a packet length that is less than or equal to 64 bytes.
65-127 Bytes Rx Pkts	Indicates received packets with a packet length that is between (includes) 65 ~ 127 bytes.
128-255 Bytes Rx Pkts	Indicates received packets with a packet length that is between (includes) 128 ~ 255 bytes.
256-511 Bytes Rx Pkts	Indicates received packets with a packet length that is between (includes) 256 ~ 511 bytes.
512-1023 Bytes Rx Pkts	Indicates received packets with a packet length that is between (includes) 512 ~ 1023 bytes.
1024-1518 Bytes Rx Pkts	Indicates received packets with a packet length that is between (includes) 1024 ~ 1518 bytes.

**Table 6-3. Port Statistics Screen Controls (Continued)**

Control	Description
1519-9216 Bytes Rx Pkts	indicates received packets with a packet length that is between (includes) 1519 ~ 9216 bytes.
1519-9216 Bytes Tx Pkts	indicates transmitted packets with a packet length that is between (includes) 1519 ~ 9216 bytes.

### 6-3 VLAN

Virtual LAN (VLAN) is a technology used to create several independent logical networks in a physical network. Hence, it reduces the size of the broadcast domain in a network. Packets are forwarded within the same VLAN. It can also be used to combine several network segments into a same group of networks that appear as a single LAN to create a flexible and extensible LAN network system. The VLAN screen is shown in [Figure 6-8](#).

**Figure 6-8. VLAN Screen**

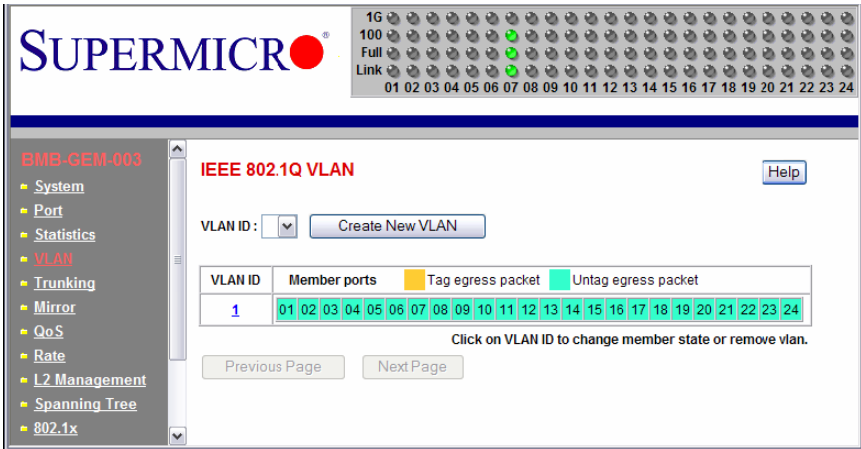

The switch supports an 802.1Q tagging VLAN. All packets entering the port of a switch only can be forwarded to a port that is a member of same VLAN. The ingress untagged frames are tagged by a per-port default tag (PVID). The forwarding decision is based on this assigned default PVID. If the ingress frames are 802.1Q tagged, the port won't alter the frames but will keep the frame's VLAN information intact. Tagged frames are forwarded according to a VID contained within the tag.

The switch also supports ingress filtering. The switch will examine the VLAN information in the incoming packets header to determine whether to drop or forward the packets. If the incoming frame has tagged VLAN information, the ingress port will check itself to see if it is a member of the tagged VLAN. If it is not, the frame will be dropped. If it's a member of the tagged VLAN, then it will check the destination port to see if it is a member of the tagged VLAN. If not, the frame is dropped. If the destination is a member

of the VLAN, the frame is forwarded to the destination port. If the incoming frame is not tagged with VLAN information, the ingress port will use PVID as the VLAN ID. If the destination port is not in the same VLAN, the frame is dropped.

The switch is initially configured to have one VLAN and its VID is 1. This VLAN is called the default VLAN. By default, all ports are initially assigned to the default VLAN.

Frames can not be forwarded across VLANs. Frames, whether they are unicast, multicast or broadcast, cannot flow from one VLAN to another VLAN unless there is a VLAN routing device to bridge them.

The switch also allows a user to configure the egress packets to either tagging or untagging. The untagging feature of 802.1Q VLAN allows a user to hook up the port to a legacy switch that doesn't recognize 802.1Q tagging header in the packet. Also, the tagging feature allows VLANs to span into multiple 802.1Q compliant switches through physical connections between switches.

## 6-4 Configuring a Static VLAN

The switch currently supports static VLANs only. To configure the VLAN, click on the VLAN folder at the left-hand side bar. The IEEE802.1Q VLAN screen should appear as shown in Figure 6-8. It lists the entire current VLAN configuration and also allows a user to create a new VLAN or modify port membership of a VLAN. The MEMBER PORTS indicates the number of member ports of the VLAN. There are two color symbols for each port to indicate tagging or untagging of packets egress from the port:

- Orange: Indicates a tagged egress packet
- Teal: Indicates an untagged egress packet

### Creating a New VLAN

1. Click on the CREATE NEW VLAN button. The screen as shown in Figure 6-9 should appear.

Figure 6-9. Creating a New VLAN

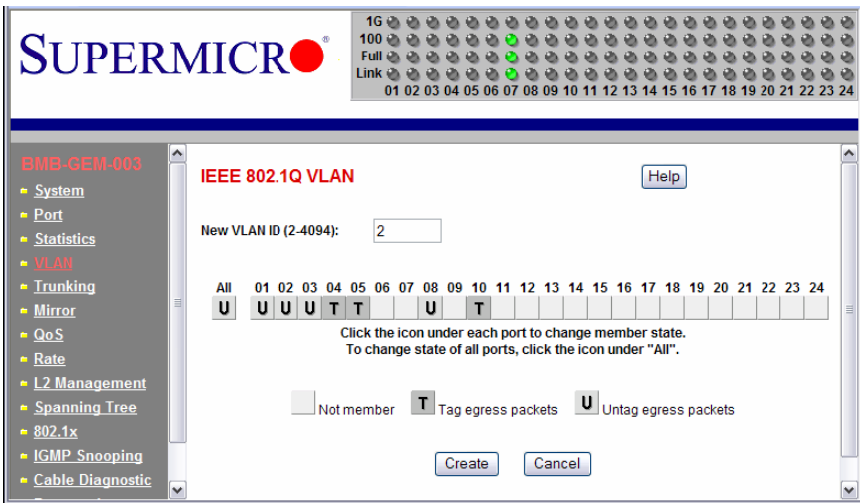

2. Assign a new VLAN ID, then click on the icon under each port to change the member state. There are three states to choose from: untag egress packets, tag egress packets and not member of a VLAN.

- Click on the CREATE button to create the new VLAN. A new VLAN is shown in Figure 6-10.

Figure 6-10. New VLAN Screen

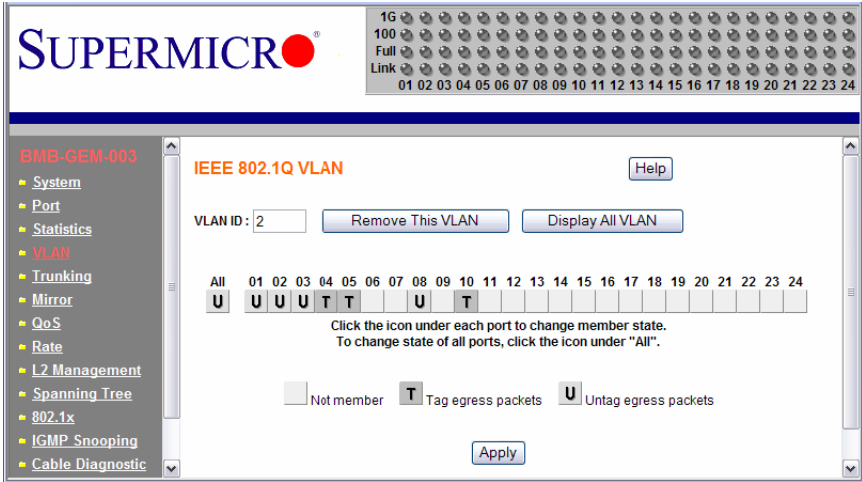

- If you want to remove this VLAN, click on the REMOVE THIS VLAN button. Click on DISPLAY ALL VLAN to list all of current VLAN configuration.
- To change the port member state or remove a VLAN, select the VLAN either from the VLAN ID drop down menu or by clicking on the VLAN ID in the table in Figure 6-8. This screen shows the current member state of the selected VLAN. Users can modify the port member state, apply a change or remove the VLAN.

## 6-5 Trunking

Trunking aggregates multiple physical ports link into a single trunk to provide a single logical high-speed pipeline link. This is useful for switch-to-switch, switch-to-server and switch-to-router applications. The SuperMicro Gigabit Ethernet switch supports static type link aggregations. It uses a distribution algorithm to balance traffic between trunk members. This aggregates the bandwidth of the trunk. The switch considers a trunk as a single port entity regardless of the trunk composition.

The switch supports up to four separate trunks. Each trunk consists of 2 to 8 ports. A port in one trunk cannot simultaneously be in another trunk. Link aggregation is supported only on point-to-point links with the MAC operating in full duplex mode. All links in a trunk must operate at the same data rate.

The links within a trunk should have an equal amount of traffic to achieve maximum efficiency in a multiple-link trunk. Thus, some sort of load balancing among the links in a trunk is employed. One requirement for load balancing is that the frames being

transmitted must not be out of order. The switch performs load balancing based on a distribution algorithm that used the following information to assign conversation to ports:

- MAC source address
- MAC destination address
- MAC source address + destination address

The user can choose one of the distribution criteria from the configuration screen as shown in [Figure 6-11](#).

**Configuring the Trunk**

1. Click on TRUNKING folder on left-hand side bar to bring up the TRUNK SETTING screen, as shown in [Figure 6-11](#).

**Figure 6-11. Trunking Screen**

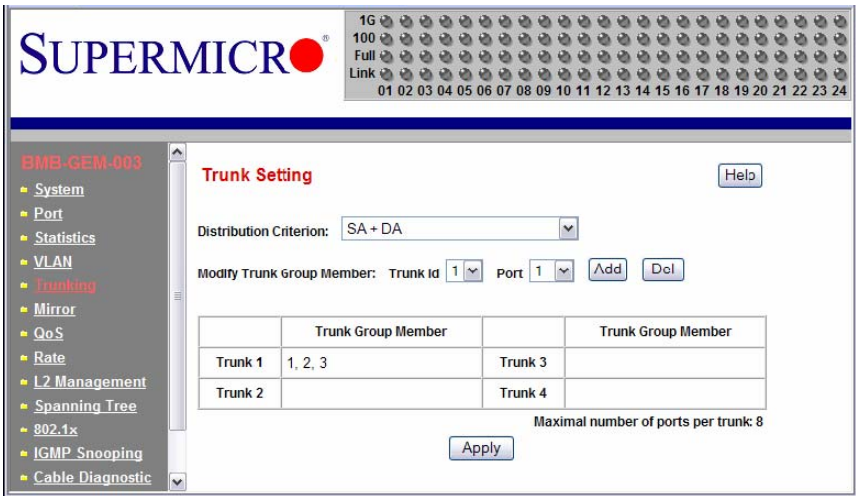

2. Click on the TRUNK ID drop down list to select the trunk group to which you want to add port member.
3. Click on the PORT drop down list to select the port number which you want to add to the selected trunk.
4. Click on the ADD button to add it in. The port number should show up under the TRUNK GROUP MEMBER in the table. Click the DEL button to delete a port member from the selected trunk.
5. Select one of the distribution criteria for the load balancing algorithm.
6. Then, click APPLY button to update and save to a new setting.

## 6-6 Mirroring

The switch supports port mirroring. A copy of the egress (transmit) data and the ingress (receive) data of the mirrored (monitored) port is sent to the mirroring (snooping) port. A user can attach a monitoring device to the mirroring port, such as a sniffer or an RMON probe to view the traffic at the mirrored port. This is useful for network monitoring and troubleshooting.

The switch allows for only one mirrored port at any given time. Port mirroring is independent from L2 switching. The receive mirrored port still forwards the frame to the mirroring port, even if the frame is eventually dropped.

To configuring port mirroring, click on the MIRROR folder in the left-hand side bar. The MIRROR SETTING screen should appear as in [Figure 6-12](#).

**Figure 6-12. Port Mirroring Screen**

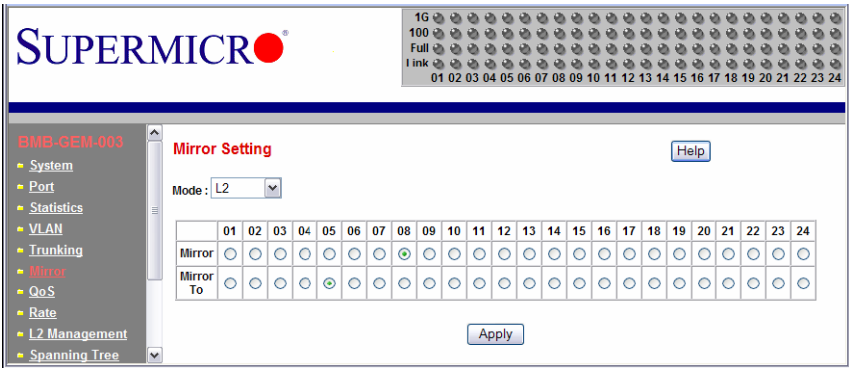

**Table 6-4. Port Mirroring Screen Controls**

Control	Description
Mode	This enables or disables mirroring. Select L2 to enable the mirroring.
Mirror	This specifies a Mirror port to which ingress and egress traffic will be mirrored.
Mirror To	This specifies the mirrored-to port.
Apply	This applies the mirror setting to the system.

## 6-7 Quality of Service

Quality of Service (QoS) helps a network user to reserve a guaranteed bandwidth for some critical application functions that require a high bandwidth and high priority. Applications such as video, audio streaming, VoIP and video conferencing must have a certain amount of bandwidth to maintain their operation correctly. QoS allows user to prioritize network traffic, thereby providing better services for those applications with a higher priority.

The switch supports 802.1p priority queuing QoS based on the priority bit in a frame's VLAN header. The 802.1p priority bit, if present in the frame, specifies the priority of the frame during forwarding. The 802.1p standard uses eight (0-7) priority levels for network traffic. Priority level 7 is the highest priority. Priority level 0 is the lowest level.

### Priority Queues

Four priority queues are provided for each port. The priority queues are labeled from 3 to 0. Priority queue 3 has highest priority while queue 0 has lowest priority. The switch transmits the frames based on the priority of the queue, not the priority tag. Frames in a higher priority queue are served more often than frames in a lower priority queue.

User configurable mapping (priority queue assignment) between the eight 802.1p priority classes and the four priority queues is provided. If the incoming frame is untagged, the switch uses the priority field in the per-port default priority (configurable in the PORT folder) to assign a frame to a priority queue. If the incoming frame is tagged or priority-tagged, the switch uses the priority field in the incoming frame to assign the frame to a priority queue.

The scheduling for transmission among the four priority queues is accomplished by one of the two user-configurable schemes: strict (fixed) priority and weighted round-robin.

For strict priority based scheduling, the packets which were put in the higher priority queue are transmitted first. If there are multiple frames with different priority tags in the same priority queue, the frame with higher priority level is transmitted first. After all frames in the higher priority queue have been transmitted, the frames in the lower priority queue will start transmitting.

For the weighted round-robin based scheduling, the number of packets served in the priority queue is determined by the weight number. After those packets are transmitted, the service moves to transmit the packets in the next queue. Therefore, a higher priority queue should have a higher weight number than a lower priority queue. The weight number is from 1 to 15 for the switch. If each queue has same weight number, then each queue has an equal opportunity to transmit frames just like in round-robin queuing.

To configure the QoS, click the QoS folder on the left-hand side bar. It should display as shown in [Figure 6-13](#).

The QoS SETTING sets the priority relationship between the four queues, selects the scheduling method for those queues, associates packets of specific priorities to specific queues, and specifies a "weight" for each queue.



Figure 6-13. QoS Setting Screen

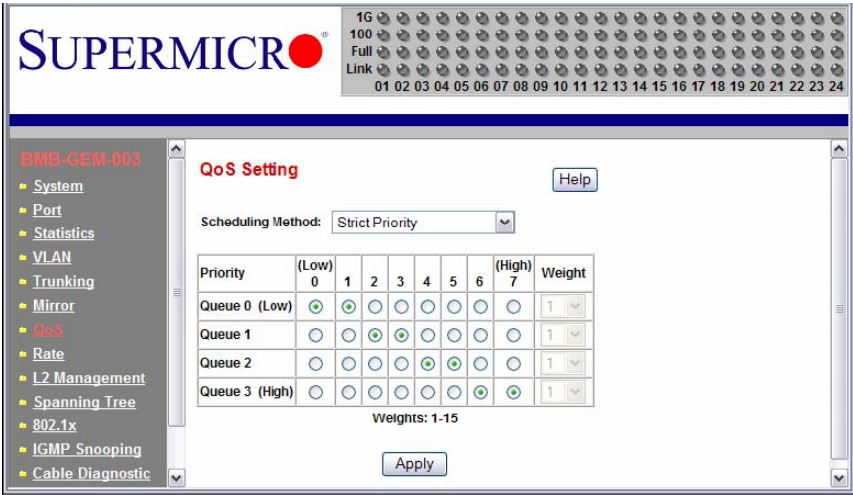

Table 6-5. QoS Setting Screen Controls

Control	Description
Scheduling Method	This specifies one of the two scheduling methods (Strict and Weighted Round-Robin) for the queues.
Queue [0:3]	Queue [0:3] prioritizes the four queues. Queue 0 is the lowest priority queue and queue 3 is the highest priority queue. Packets in queue 3 are served more often than packets in queue 0.
Priority	This indicates packet priority. This value is retrieved from the priority tag field, with values from 0 to 7. 0 indicates the lowest priority and 7 indicates the highest priority. Click on the radio button to send packets of a specific priority to a particular queue.
Weight	This indicates the weight (number of packets) to be served in the queue before moving to serve the next queue. A high priority queue should have a higher weight than a low-priority queue.

## 6-8 Rate Control

The switch supports per-port rate control. When the data rate of the incoming frame for a particular port exceeds a selected rate, the excess frame traffic is subject to packet drops or flow control, depending on the per-port flow control configuration in the PORT folder. If the flow control of a particular port is enabled, then the switch uses flow control to inhibit any excess traffic. If the flow control is disabled, the excess frames will be dropped.

To configure the ingress rate limit for a port, click on RATE in the left-hand side bar. The RATE LIMIT AND STORM CONTROL screen appears as [Figure 6-14](#).

Figure 6-14. Rate Limit and Storm Control Screen

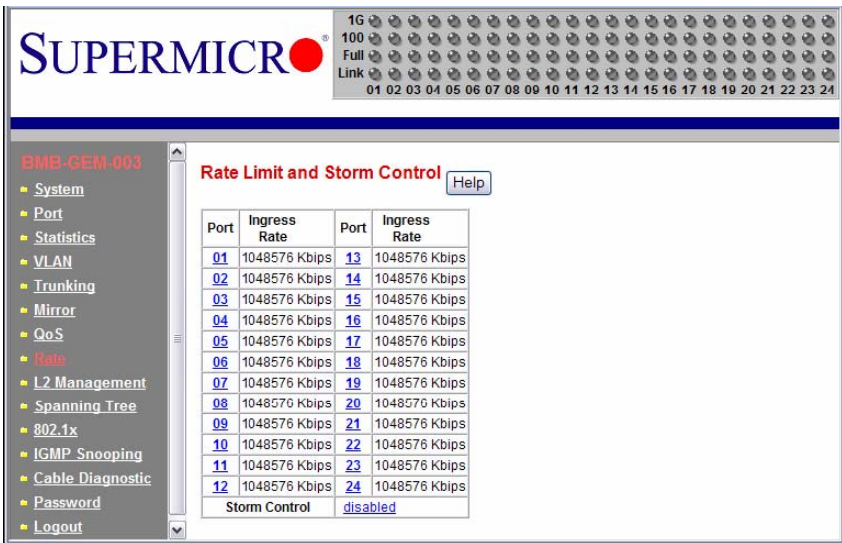

The screen shows the Ingress Rate (in kilobits per sec) for all ports. Click on the port number to control the ingress rates for the port. There are eight different levels to select: *no limit (1Gbps)*, *256Kbps*, *1Mbps*, *4Mbps*, *16Mbps*, *64Mbps*, *128Mbps* or *512Mbps*. The STORM CONTROL indicates the current status of storm control.

A traffic storm happens when broadcast, multicast or unknown unicast packets flood the network, which will degrade the network performance. The storm control monitors the traffic of an incoming particular type of frame (configured by the user) and limits traffic to a user configurable rate level (threshold). The storm rate threshold is counted in number of packets per second (pps). If the traffic of a particular frame type exceeds the threshold during one second, all the rest of that type of frame will be dropped before the end of that second.

The switch provides configuration to assign storm control type and rate limitations to the entire system.

To configure storm control, click **STORM CONTROL** link in the **RATE LIMIT AND STORM CONTROL** screen (Figure 6-14). The **STORM CONTROL** screen appears as shown in Figure 6-15.

**Figure 6-15. Storm Control Screen**

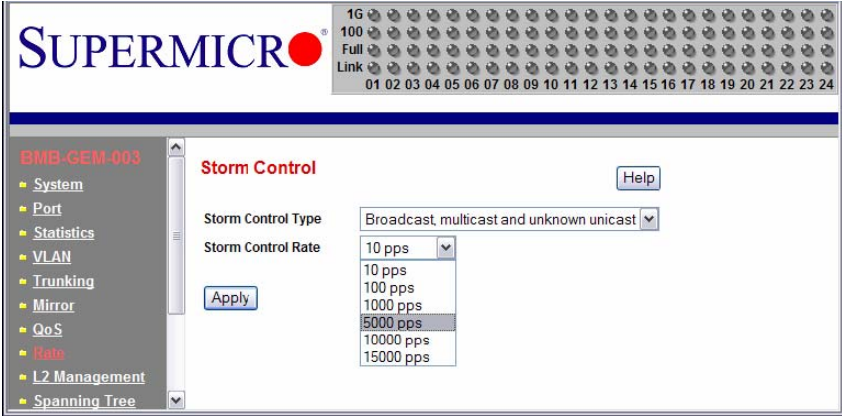

**Table 6-6. Storm Control Screen Controls**

Control	Description
Storm Control Type	This selects the type of the packet storm. The figure below shows all available options: Broadcast only, Broadcast and multicast, Broadcast unknown unicast and Broadcast, multicast, and unknown unicast.
Storm Control Rate	This selects a rate (packets-per-second) for storm control. The figure below shows all available options: 10 pps 100 pps 1000 pps 5000 pps 10000 pps and 15000 pps.

## 6-9 L2 Management

L2 management provides a way to add, delete, and look up MAC addresses in the L2 address table. The switch supports 8192 L2 address table entries, each specifying a MAC address, VLAN ID, destination port number, trunk ID and Rtag. The switch supports store-and-forward mode switching.

After a frame is received, its source MAC address (MACSA) and destination MAC address (MACDA) are retrieved. Depending on the port state, the MACSA and port number may be used to dynamically update the L2 address table. The MACDA may be used to determine the frame's destination port. User can also statically add a MAC address to the L2 address table.

To add a static entry into the L2 ADDRESS table, click on the **ADD** link on the **L2 ADDRESS MANAGEMENT** screen as shown in Figure 6-16.

Figure 6-16. L2 Management Screen

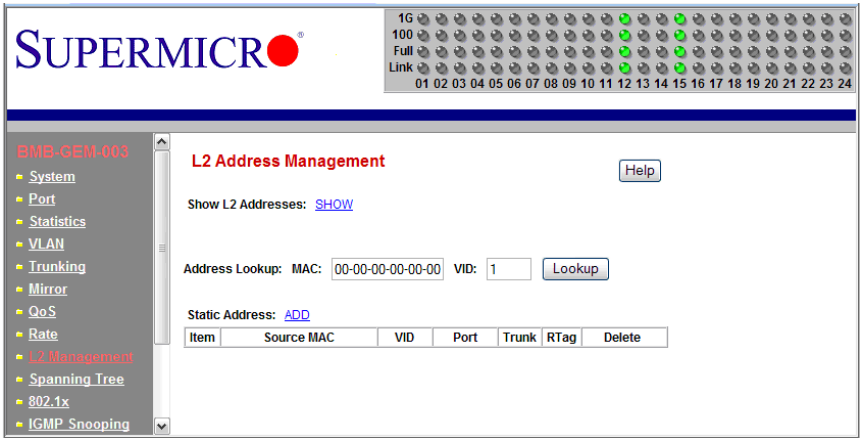

To remove the specified static MAC address from the table, click the DELETE link for that MAC address as shown in Figure 6-17 when there are static entries in the table.

To search for a MAC address to see if it exists in the table or not, enter the MAC ADDRESS and VID, then click on LOOKUP button. If the MAC address is in L2 ADDRESS table, whether it is a static or a dynamic MAC address, the result will be displayed.

To show all of MAC address in the L2 table, click the SHOW link next to SHOW L2 ADDRESSES.

Figure 6-17. L2 Management: Current Entries Screen

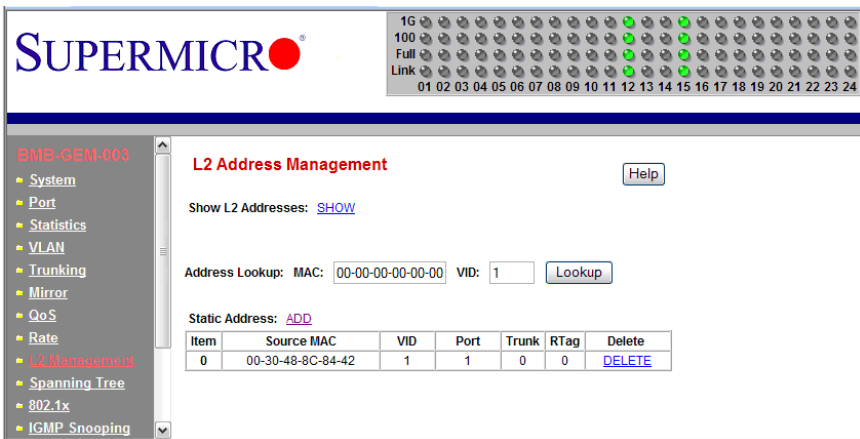

## 6-10 Spanning Tree

The Spanning Tree Protocol (STP) helps to detect and prevents loops from occurring on a switched or bridged network. When multiple paths exist on a network, STP will configure the network to use the most efficient path between network devices. All other paths are forced into a blocked standby state. If the active path fails, then STP will automatically select another path to become the active path on the network to sustain normal network operations. An active path is selected by comparing path costs defined on each path. The path with the lowest cost will be selected.

The switch supports IEEE802.1d Spanning Tree Protocol and IEEE802.1w Rapid Spanning Tree Protocol (RSTP). The Rapid Spanning Tree Protocol significantly reduces the convergence time by assigning port roles and by determining the active topology. A reconfiguration of the spanning tree can occur in less than one second. The RSTP is backward compatible with legacy devices running IEEE802.1d STP and serves as an STP device when an STP device is present in the network.

### Bridge Protocol Data Unit (BPDU)

The spanning tree is built by obtaining switch information by exchanging Bridge Protocol Data Unit (BPDU) packets among the participating switches. When RSTP is enabled for a switch, it will generate a BPDU and periodically forward it out through each port on the switch. The interval is configurable through the Hello Time, which is set to a two second default. This enables the switch to keep track of network topology changes and enable or disable ports as required.

The BPDU contains the information about the transmitting switch and its ports including MAC address, bridge priority, port priority and port path cost. The BPDU packet is sent out by using the unique MAC address of the port itself as a source address, and the destination address of the STP multicast address 01:80:C2:00:00:00.

There are three types of BPDUs:

- Configuration BPDU – for spanning tree computation
- Topology Change Notification (TCN) BPDU – announces changes in network topology.
- Topology Change Notification Acknowledge (TCA) BPDU

The major operation of the spanning tree protocol includes a root bridge election, finding paths to a root bridge, determining the least cost path to root and disabling all other root paths. When a RSTP enabled switch is turned on, it automatically assumes that it is the root bridge in the spanning tree. The software in the switch will elect a switch as the root bridge based on the Bridge ID in the received BPDU. The Bridge ID is an 8-byte field which combines a high order two-byte bridge priority number and a lower order six-byte switch MAC address. The switch with the lowest Bridge ID will be elected as the root bridge.

All RSTP participating switches will use an algorithm to determine how close they are to the root bridge, which is known as Path Cost. The path with lowest cost will be selected as the active path. All others will be blocked (standby). TCN packets are injected into the network by a non-root switch and propagated to the root. Upon receipt of the TCN, the

root switch will set a Topology Change flag in its normal BPDUs. This flag is propagated to all other switches to instruct them to rapidly age out their forwarding table entries.

### Port Transition State

When a device is connected to an RSTP or STP enabled switch port for the first time, it will not immediately start to forward data. Instead, it will go through a number of states while it processes BPDUs and determines the network topology.

There are five port states in the legacy 802.1d STP: *disabled*, *blocking*, *listening*, *learning* and *forwarding*. The RSTP combines the *disabled*, *blocking* and *listening* states used in 802.1d STP and creates a single state: *Discarding*. Table 6-7 lists the comparison of port states between 802.1d STP and 802.1w RSTP.

**Table 6-7. Comparison of Port States**

State Displayed	802.1d STP	802.1w RSTP
Discarding	Disabled	Discarding
Discarding	Blocking	Discarding
Discarding	Listening	Discarding
Learning	Learning	Learning
Forwarding	Forwarding	Forwarding

### RSTP Port Roles

RSTP will assign port roles for each port during the process receiving the BPDUs. Based on its port role, a port can either send or receive BPDUs and forward or block data traffic.

- **Root** – the port that provides the lowest cost path when the switch forwards packets to the root switch.
- **Designated** – the port closest to the root switch and forwarding traffic toward the root switch and sending BPDUs in a link segment. Each designated port is in a forwarding state.
- **Alternate** – this port provides an alternate path to the root bridge. This path is different than using the root port. The alternate port is in a blocking state.
- **Backup** – the port provides a backup/redundant path to a link segment to which another switch port already connects. This is a special case when two or more ports of the same switch are connected together.
- **Disabled** - Not a strictly part of RSTP, a network administrator can manually disable a port.

To configure the RAPID SPANNING TREE, click the SPANNING TREE folder on the left-hand side bar. There are two portions to configure: RSTP SWITCH SETTINGS and RSTP PORT SETTINGS, as shown in the RAPID SPANNING TREE screen (Figure 6-18).

Figure 6-18. Rapid Spanning Tree Screen

**SUPERMICR**

1G 100 Full Link  
01 02 03 04 05 06 07 08 09 10 11 12 13 14 15 16 17 18 19 20 21 22 23 24

**BMB-GEM-003**

- System
- Port
- Statistics
- VLAN
- Trunking
- Mirror
- QoS
- Rate
- L2 Management
- Spanning Tree**
- 802.1x
- IGMP Snooping
- Cable Diagnostic
- UpLink Failure Track
- Password
- Logout

**Rapid Spanning Tree** Help

**RSTP Switch Settings**

Enable RSTP

Designated Root Bridge	Root Status	Bridge Setting
Priority (0 - 61440)	32768	32768
Max Age (6-40 sec)	20	20
Hello Time (1-10 sec)	2	2
Forward Delay (4-30 sec)	15	15

Note: 2\*(Hello Time+1) <= Max Age <= 2\*(Forward Delay-1)

Apply Global Settings

**RSTP Port Settings** Edit

Port	Participate	Cost	Priority	Edge	P2P	Status	Role
01	<input type="checkbox"/> No	-	-	-	-	-	-
02	<input type="checkbox"/> No	-	-	-	-	-	-
03	<input type="checkbox"/> No	-	-	-	-	-	-
04	<input type="checkbox"/> No	-	-	-	-	-	-
05	<input type="checkbox"/> No	-	-	-	-	-	-
06	<input type="checkbox"/> No	-	-	-	-	-	-
07	<input type="checkbox"/> No	-	-	-	-	-	-
08	<input type="checkbox"/> No	-	-	-	-	-	-
09	<input type="checkbox"/> No	-	-	-	-	-	-
10	<input type="checkbox"/> No	-	-	-	-	-	-
11	<input type="checkbox"/> No	-	-	-	-	-	-
12	<input type="checkbox"/> No	-	-	-	-	-	-
13	<input type="checkbox"/> No	-	-	-	-	-	-

The RSTP SWITCH SETTINGS allows the user to control RSTP parameters from the bridge point-of-view. ROOT STATUS shows status of the root bridge. BRIDGE SETTING shows the current bridge setup.

To turn on the Rapid Spanning Tree Protocol (RSTP), check on the ENABLE RSTP dialog box and click on the APPLY GLOBAL SETTINGS button.

### ***Root Status***

The settings for ROOT STATUS are shown below:

- **Designated Root Bridge** – The bridge identifier of the root of the spanning tree is determined by the RSTP protocol as executed by this node. The bridge identifier value is used as the Root Identifier parameter in all configuration Bridge PDUs originated by this node.
- **Max Age** – This indicates the maximum age of the root bridge. This is the maximum age of spanning tree protocol information learned from the network on any port before it is discarded, in units of hundredths of a second. This is the actual value that this bridge is currently using.
- **Hello Time** – This indicates the amount of hello time of the root bridge. Hello time is the amount of time between the transmission of configuration Bridge PDUs by this node on any port when it is the root of the spanning tree or trying to become so, in units of hundredths of a second.
- **Forward Delay** – This indicates the amount of forward delay of the root bridge. Forward delay is a time value, measured in units of hundredths of a second, which controls how fast a port changes its state. The value determines how long the port stays in each of the listening and learning states, which precede the forward state. This value is also used to age all dynamic entries in the forwarding databases when a topology change has been detected and is underway.

### ***Bridge Setting***

Settings for Bridge Setting are shown below:

- **Priority** – This configures the priority of the current bridge.
- **Max Age** – This configures the maximum age of the current bridge. This is the maximum age of spanning tree protocol information learned from the network on any port before it is discarded, in units of hundredths of a second. This is the actual value that this bridge is currently using.
- **Hello Time** – This indicates the amount of hello time of the current bridge. Hello time is the amount of time between the transmission of configuration Bridge PDUs by this node on any port when it is the root of the spanning tree or trying to become so, in units of hundredths of a second.
- **Forward Delay** – This indicates the amount of forward delay of the current bridge. Forward delay is a time value, measured in units of hundredths of a second, which controls how fast a port changes its state. This value determines how long the port stays in each of the listening and learning states, which precede the forward state. This value is also used to age all dynamic entries in the forwarding databases when a topology change has been detected and is underway.



## RSTP Port Settings

These settings control and monitor the port-based spanning tree status.

- **Participate** – This specifies if the RSTP is enabled or not for the selected port.
- **Cost** – Displays the cost of this port. “Cost” means the contribution of this port to the path cost of paths towards the spanning tree root which include this port.
- **Priority** – Displays the priority of this port. This is the value of the priority field contained in the first octet of the Port ID.
- **Edge** – This indicates if this port is the edge port. Once configured as an edge port, the port immediately transitions to the forwarding state. It is available only when the port is directly connected to an end terminal (or a file server) that has no influence on the spanning tree configuration. Since ports 11 to 24 are connected to blade server NIC ports, all of those ports can be configured as an Edge port.
- **P2P** – This indicates if this port is a point-to-point link. If you connect a port to another port though a point-to-point link and the local port becomes a designated port, it negotiates a rapid transition with the other port to ensure a loop-free topology.
- **Status** – This displays the RSTP port status.
- **Role** – This displays the role of this port.

To modify the PORT SETTINGS for each port, click on the EDIT link next to PORT SETTING. The RAPID SPANNING TREE - PORT SETTINGS screen (Figure 6-19) will appear.

Figure 6-19. Rapid Spanning Tree Port Settings

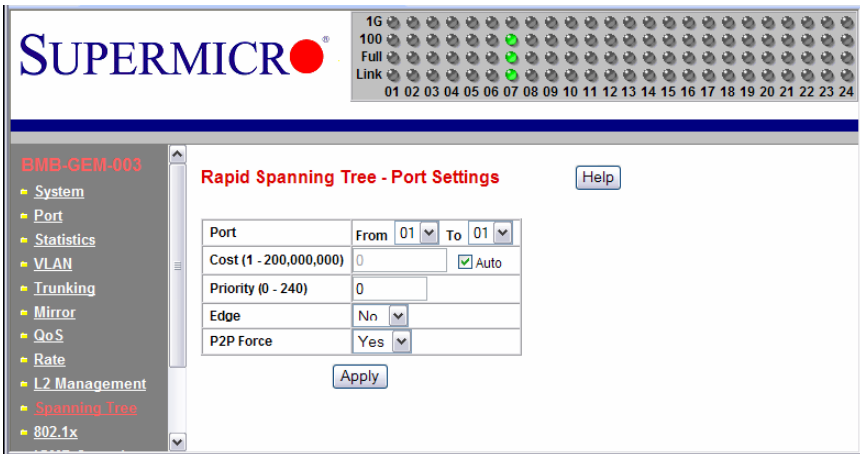

Select a group of port numbers that you want to configure. Setting the COST to zero or checking AUTO will automatically set the default value depending on the link speed. The default cost is 20000 for a Gigabit port and is 100000 for a 100Mbps port.

## 6-11 IEEE 802.1x

IEEE 802.1x is a client-server based access control and authentication protocol that restricts unauthorized user devices from connecting to the LAN through publicly accessible ports. This port-based access control is accomplished by using a RADIUS server that is connected to a gigabit switch management port to authenticate client users trying to access a network through the switch. The gigabit switch will relay Extensible Authentication Protocol over LAN (EAPoL) packets between the user client and the RADIUS server. The 802.1x protocol consists of three components: client, authenticator and authentication server.

The Authentication Server is a remote device that runs the RADIUS server program (Windows 2000/2003 IAS™, freeRADIUS™ from open source). The role of the Authentication Server is to certify the identity of a client attempting to access the network. By exchanging secure information between the RADIUS server and the client through EAPoL packets, the Authentication Server will inform the switch whether or not the client is granted access to the LAN through the connected port.

The client is a workstation that wishes to access the network through a connected switch port. All workstations have to run a program (supplicant) that is compliant with the 802.1x protocol. Microsoft Windows XP™ and Vista™ should have this. A user can also install another third party package, such as Odyssey® from Funk Software®.

When the GLOBAL RADIUS SETTING and SET STATUS of an individual port are enabled, that port will initially be placed into an unauthorized state. The client will initiate negotiations by sending an EAPoL START packet.

There are several EAP authentication methods available in Microsoft Windows XP, such as *EAP-MD5*, *EAP-TLS* and *EAP-PEAP*. Currently, the gigabit switch only supports *EAP-MD5* for 802.1x authentication.

- **PEAP-MS-CHAP v2** uses password-based credentials and requires computer certificates on the RADIUS servers.
- **EAP-TLS** uses certificate-based credentials and requires user and computer certificates on the wire's client computers and computer certificates on the RADIUS servers.
- **EAP-MD5** (Message Digest 5) Challenge Handshake Authentication Protocol (MD5 CHAP), which uses passwords.

### Wiring for 802.1x

The EAPoL packets are handled by a management processor in the switch. The processor communicates with the outside world through three ports. Two ports (eth0 and eth1) are connected to the CMM module's Ethernet port and the third port (eth2) is connected to all 24 switching ports. Only one port is enabled at any time. The regular configuration setup switch is managed through the CMM Ethernet port. Thus, for regular deployment, the RADIUS server should be located where it can be reached from the CMM Ethernet port.

## 802.1x Configuration

Figure 6-20. 802.1x Configuration Screen

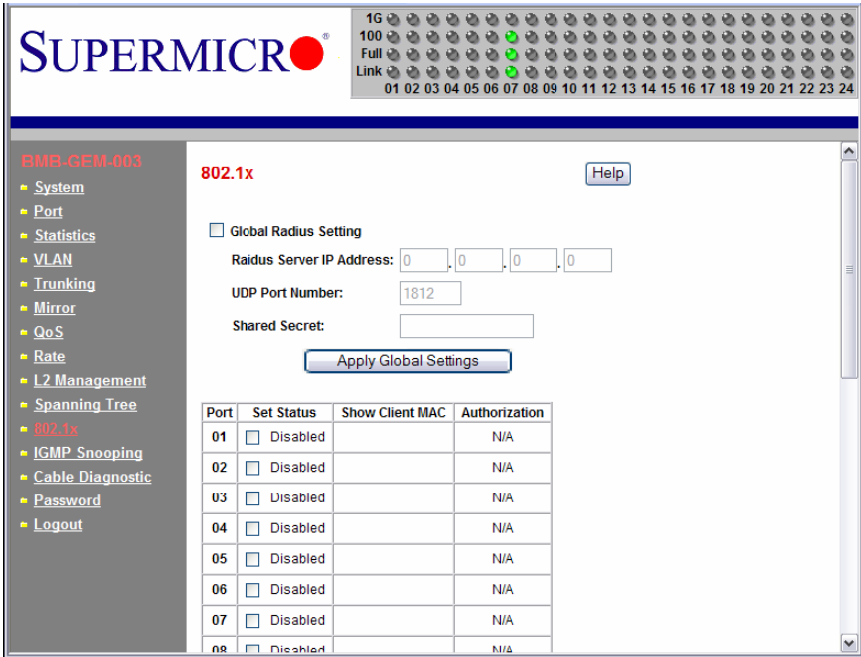

To configure 802.1x port based access control, click on the 802.1x folder in the left-hand side bar. The 802.1x configuration should display as shown in [Figure 6-20](#). Check the GLOBAL RADIUS SETTING dialog box to enable 802.1x port based access control.

- **Radius Server IP Address** – This indicates the IP address of the RADIUS server.
- **UDP Port Number** – This specifies the UDP port number of the EAPOL control frame. 1812 is the default UDP port number. If the RADIUS server can't recognize them, other numbers can be used.
- **Shared Secret** – This is a 16-character string used by the RADIUS server as a password to identify EAPOL control frames.

The PORT AUTHENTICATION SETTINGS allows you to enable or disable authentication for individual ports. It also displays the results when a port is enabled for authentication.

- **Set Status** – This enables or disables port authentication. ENABLE PORT AUTHENTICATION STATUS means a port should be authorized by a RADIUS server to forward traffic. No traffic is forwarded if it is unauthorized. No authentication process is required for those ports in disabled status; traffic can be forwarded normally.
- **Show Client MAC** – This displays the last client in the MAC address who sent out the EAPOL control frame of the port.

- **Authorization** – This displays the authentication status of an enabled port. It includes the following status:
- **In Progress** – This indicates that the authentication is still in progress. Traffic is not forwarded before authentication is verified.
  - **Yes** indicates the port access is authorized.
  - **No** indicates the port access is not authorized.
  - **N/A** means no authentication required.

## 6-12 IGMP Snooping

IP multicast is often used to distribute video/audio multimedia data over the network. The layer 2 switch will flood multicast frames to all of ports of switch, which wastes a lot of unnecessary network bandwidth. IGMP is a standard defined in RFC1112 for IGMPv1 and in RFC2236 for IGMPv2. IGMP specifies how a host can register a router in order to receive specific multicast traffic. A layer 3 switch usually supports Internet Group Management Protocol (IGMP) to manage multicast groups by sending and processing IGMP packets. To prevent the unnecessary flooding, the gigabit layer 2 switch can enable the *IGMP snooping* function to control how IP multicast packets are forwarded to required ports by monitoring IGMP queries and response packets generated by layer 3 switches or the IGMP querier.

Currently, the gigabit switch supports IGMP snooping for IGMP v1/v2 packets. In the real network setup, the switch is seated between the Multicast Router/Server and the host. The Multicast Router/Server will periodically send an IGMP v2 query packet and the host will respond with an IGMP v2 report packet if the host is in the same multicast group. When the host wants to go away, it can send an IGMP v2 Leave packet. The switch will remove the connected port number from the multicast group entry of a table. If the host is just silently removed, then the switch will clean it from table when the timer expires.

[Figure 6-21](#) shows the IGMP SNOOPING configuration screen. [Table 6-8](#) describes each configuration item.



**Table 6-8. IGMP Snooping Screen Controls**

Control	Description
Robustness Variable	This allows tuning for the expected packet loss on a subnet. If a subnet is expected to be lossy, the Robustness Variable may be increased. IGMP is robust to (Robustness Variable-1) packet losses. The Robustness Variable must not be 0, and should not be 1. The default value is 2.
Query Interval	This is the interval between general queries sent by the querier. The default interval is 125 seconds. By varying the [Query Interval], an administrator may tune the number of IGMP messages on the subnet; larger values cause IGMP queries to be sent less often.
Query Response Interval	This is the maximum response time inserted into the periodic general queries. The default value is 100 (10 seconds) By varying the query response interval, an administrator can tune the bursting of IGMP messages on the subnet; larger values make the traffic less bursty, as host responses are spread out over a larger interval. The number of seconds represented by the query response interval must be less than the query interval.
Last Member Query Interval	This is the maximum response time inserted into group-specific queries sent in response to Leave Group messages, and is also the amount of time between group-specific query messages. The default value is 10 (1 second). This value may be tuned to modify the "leave latency" of the network. A reduced value results in reduced time to detect the loss of the last member of a group.
Last Member Query Count	This is the number of Group-Specific Queries sent before the router assumes there are no local members. Default: the Robustness Variable.
Enable IGMP Snooping Feature	This is used to enable the IGMP snooping feature.
Router Ports	This specifies ports to which IGMP routers were connected.

## 6-13 SNMP

The SNMP agent in the gigabit switch supports SNMP v1 and v2c. It also supports the following MIB:

- RFC1213 MIBII with standard sets which include system, interfaces, IP, ICMP, TCP, UDP, Dot3, and SNMP.
- RFC2011 SNMPv2 MIB for IP using SMIv2
- RFC2665 EtherLike MIB

## 6-14 UpLink Failure Tracking (ULFT)

Uplink Failure Tracking (ULFT) feature is provided to support network adapter Teaming (Windows Systems) or Channel Bonding (Linux Systems) on SuperBlade servers.

Installing two GbE switch modules can have additional connectivity to allow increased network bandwidth, redundancy, and/or fault tolerance. The connection between internal ports of the switch and each LAN port of the server blades is hardwired through the middle plane. The link will not be dropped unless either switch's internal port or the server blade's LAN port fails.

By enabling the ULFT feature with proper pair configuration, a failover event can be triggered in the Teaming or Channel Bonding program when all of a switch's external uplink member ports fail. The switch automatically enables the internal downlink ports once one of the uplink ports in the configured pair returns to service.



**NOTE:** By default, the switch's ULFT feature is disabled. The link status on the external uplink ports does not affect the link status of internal downlink ports.

To use ULFT, you must configure a Failure Tracking Pair and enable the ULFT feature. A Failure Tracking Pair consists of uplink and downlink ports. The uplink tracking member contains at least one of the external ports: port 1 to port 10. The downlink tracking member contains at least one of the internal ports: port 11 to port 24.

If Trunking is enabled on the external uplink ports, then all of the trunk member ports should be configured as uplink members of a tracking pair. The link to the configured internal downlink member ports is disabled when **all** of the trunking uplink member ports fail. [Figure 6-22](#) shows the UPLINK FAILURE TRACKING CONFIGURATION screen. [Table 6-9](#) describes each configuration item.

For example, if your SuperBlade has two blade servers installed on slot 1 and slot 3, then each blade has two LAN ports, one connected to the internal port of the upper GbE switch and the other one connected to the internal port of the bottom GbE switch. To implement switch redundancy, you need to have two GbE switches installed. Each of these GbE switches should enable the UpLink Failure Tracking feature and have the exact same proper configuration as shown in [Figure 6-22](#).

The pair configuration in this example defines the ULFT for blade 1 and blade 3. The external port 5 of each switch is connected to an external third party switch through an Ethernet cable. This assumes that the Network Adapter Teaming or Channel Bonding has a proper configuration and is running on each of the blades.

If one of the external Ethernet cables is broken or the third party switch port to which the cable connects fails, then one of the SuperBlade GbE switches will detect a link drop on its external port 5 and turn down the link on its internal ports 11 and 13. The Teaming or Channel Bonding software running on both of these blades then detects a link drop on one of its LAN ports and switches to another LAN port automatically. This allows network traffic to go through another GbE switch.

Note that ULTF will only drop an internal link from the blade to the switch if all of the (external) uplinks defined for that blade have failed (or been disabled) on that switch. As long as one or more of uplinks on a particular switch (that have been defined for a particular downlink) is active, the blade and switch will keep the internal link active.

**Figure 6-22. Uplink Failure Tracking Configuration Screen**

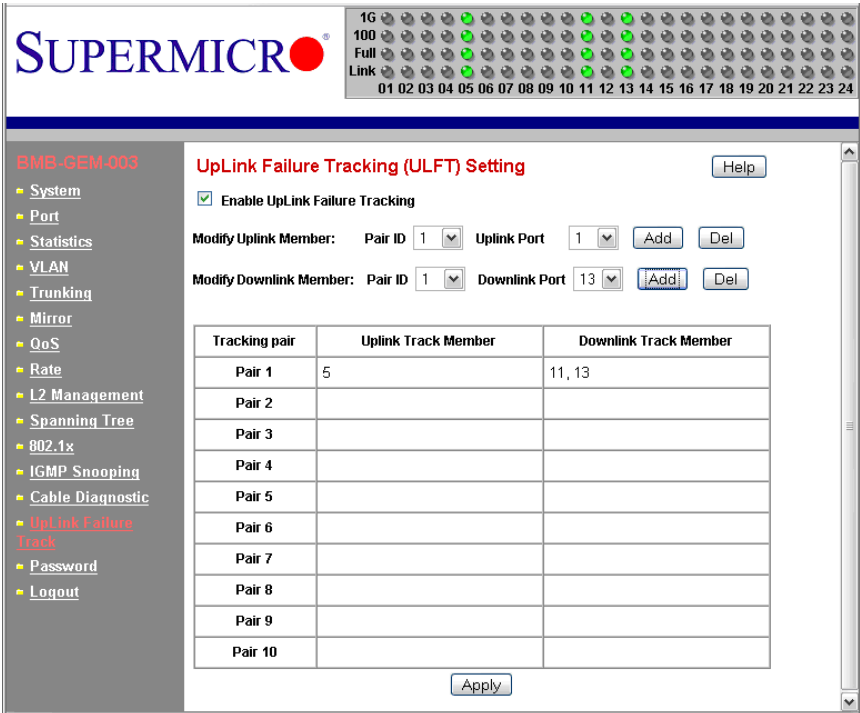

**Table 6-9. Uplink Failure Tracking Configuration Screen Controls**

Control	Description
Enable UpLink Failure Tracking	Enables/Disables the UPLINK FAILURE TRACKING feature.
Modify UpLink Member	Select the pair ID and uplink port number to add/delete to/from uplink member of a pair.
Modify Downlink Member	Select the pair ID and downlink port number to add/delete to/from downlink member of a pair.
Uplink Track Member	This column defines member ports of an uplink in a ULFT pair.
Downlink Track Member	This column defines member ports of a downlink in a ULFT pair.



---

---

# Chapter 7

## Layer 2/3 Ethernet Switch Firmware

This chapter is provided to help you quickly get started in using the firmware for your SBM-GEM-X2C(+)/SBM-GEM-X3S+, 1/10-Gigabit Ethernet or SBM-XEM-X10SM 10-Gigabit Ethernet switch module, using the web-based management GUI tool.



**NOTE:** The 1/10-Gigabit Ethernet switch module is available in three versions:

- SBM-GEM-X2C which supports 10 or 14 blade enclosure systems
- SBM-GEM-X2C+ which also supports twin-blade (20 node) systems in addition to the 10 and 14 blade enclosures.
- SBM-GEM-X3S+ which supports all blade enclosures and provides three SFP+ 10GbE uplink ports

Except for the the maximum number of blades supported, both the SBM-GEM-X2C and SBM-GEM-X2C+ are identical. The “SBM-GEM-X2C(+)” part number is therefore used throughout the rest of this manual to refer to features and operational characteristics of both versions.



**NOTE:** The 10-Gigabit Ethernet switch module is available in only one version, the SBM-XEM-X10SM. This module supports either or the following configurations:

- Twin blade (20 node (SBE-720E enclosure)) systems with a configuration that has four external 10-Gbps Ethernet ports available
- 10-blade systems (SBE-710Q enclosure) whose configuration has ten external 10-Gbps Ethernet ports available



**NOTE:** See the SM-CLI Guide included on your SuperBlade Switch System CD-ROM for further information on the 1/10 Gigabit Ethernet switch firmware and its controls using the CLI.

### 7-1 Overview

The Supermicro switch utility for the Layer 2/3 Gigabit Ethernet switch modules provides a web-based interface for managing layer2 and layer3 switching at wire speed for constructing a switched/routed network. This interface provides both a bridging functionality and advanced features such as link aggregation, Dynamic VLAN/Dynamic Multicast, IGMP Snooping and Network Access Control. This web-based interface also comes with several Layer3 features as well (such as wire speed routing, Differentiated services, multicast routing and so on).

The Supermicro Switch firmware is implemented using open sources from OpenSSL, OpenSSH and other open source communities and is configured using web browsers such as Internet Explorer.

The utility starts with a default IP address, which is also the management IP address. This IP address is essentially provided for remote management of this switch. For managing the switch through web browsers, type in the default IP address in your browser's web address in order to start accessing the switch.

For example, if the management IP address of the switch is **192.168.1.1**, the switch can be accessed through the Web browser by typing <http://192.168.1.1> in the address space of the web browser.

The default management IP address for Supermicro Switch products is **192.168.100.102**. This default IP address can be changed in the SYSTEM SETTINGS page in the System Management section.

The management interface for the SBM-GEM-X2C(+), SBM-GEM-X3S+ and the SBM-XEM-X10SM is the same as that for the Supermicro standalone SSE-G24-TG4 and SSE-G48-TG4 1/10-Gigabit Ethernet switch modules.

For the SSE-G48-TG4 and SSE-G24-TF4 switches, you can connect to any of the front panel 1G ports or back panel 10G ports to manage the switch with the default management IP. These switches will create VLAN 1 by default with this IP address, including all 1G and 10G ports.

The SBM-GEM-X2C(+), SBM-GEM-X3S+ and SBM-XEM-X10SM blade switches can be managed with the default IP through CMM Ethernet connections, since their internal management Ethernet ports are connected with CMM Ethernet ports internally. If you prefer to manage the SBM-GEM-X2C(+) or SBM-XEM-X10SM switch through front panel ports or through any other switching ports, then you can assign the desired management IP address to VLAN 1. Alternatively, you can create any VLAN and manage the switch through switching ports. Here the term switching ports refer to all internal and external 1G and 10G ports of the switch.

### Nomenclature

The following nomenclature applies to screens found in this chapter:

- **Port \*/\*** – This indicates the stacking ID number, port number
- **Port Number GB \*/\*** – This is for an internal port
- **Port Number Ext \*/\*** – This is for an external port.

## 7-2 Login

Figure 7-1. Login Page



The initial login page (Figure 7-1) is used to login to the Supermicro Switch web-based management utility for 10-Gbps switches. To login, enter your **User Name** and **Password** in the fields provided and press the LOGIN button.

This User Name and Password are both used for accessing the switch through the web for switch configuration. The entered user name and password are validated at the switch end.

After logging in, you will be taken to the HOME page of the utility. See [Section 7-3: Home Page on page 7-3](#) for further details.

## 7-3 Home Page

The HOME page (Figure 7-2) contains links and menus for going to all other control pages in the Supermicro Switch web-based interface utility. A list of controls for this page is shown in [Table 7-1](#). The basic page structure of the HOME page is duplicated for all subsequent sub-pages of the Supermicro Switch web-based interface utility.

Figure 7-2. Home Page

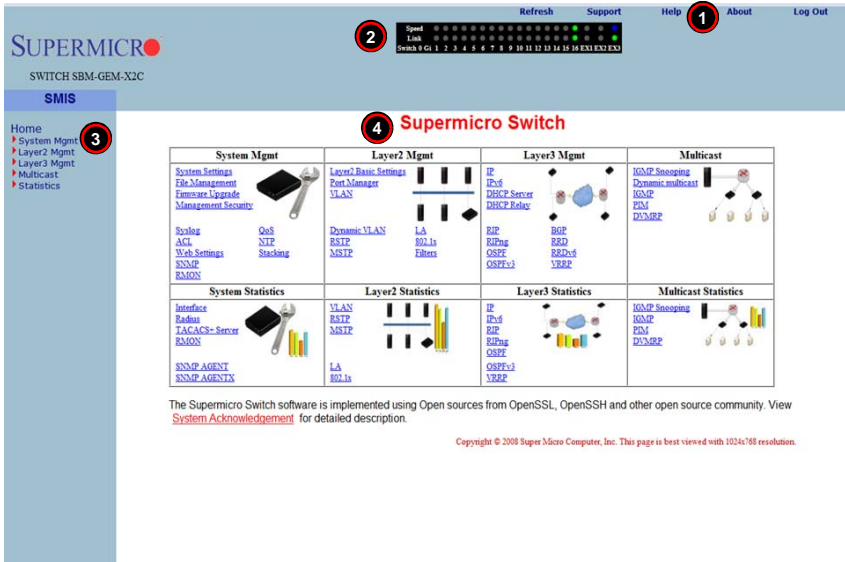

Table 7-1. Home Page Controls and Components

Number	Name	Description
1	Top Page Links	The Top Page Links are present both on the Home page and all other pages accessed and contain links to support pages or additional controls for all pages viewed with the Web Management Utility. See "Top Page Links" below for further details.
2	Top LED Display	This section of the screen provides an overview port status for the switch. See "Top Page Links" for further details.
3	Left Side Tree	The Left Side Tree contains an expandable list of links for you to use to get to other management pages. All configuration pages contain this navigation tree.
4	Middle Configuration Links Table	Each configuration page contains its own links and controls

The HOME page is displayed on successful validation of the user name and password. The information in this page presents a brief overview of the switch web-based management utility. See Figure 7-3, Figure 7-4, Figure 7-5 and Figure 7-6 for different views of the Home page for each of Supermicro's Layer 2/3 switches.

Figure 7-3. SBM-GEM-X2C(+) Home Page

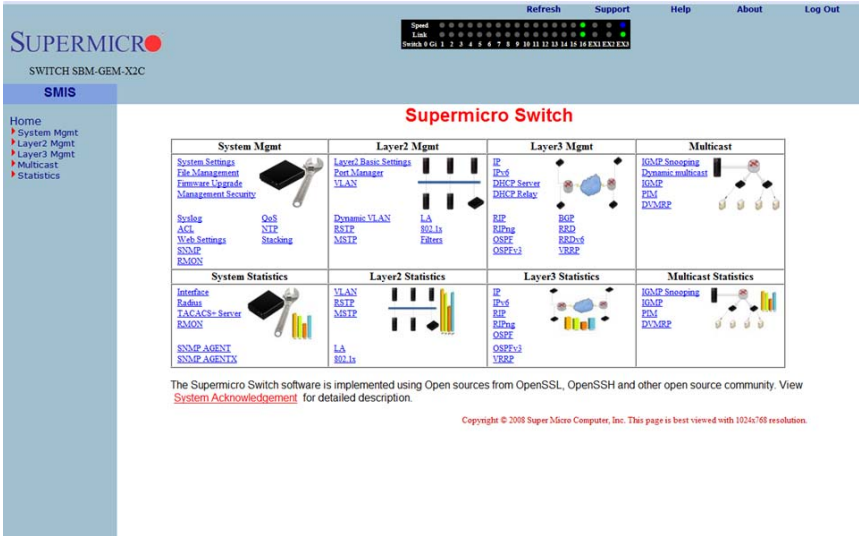

Figure 7-4. SBM-XEM-X10SM Home Page

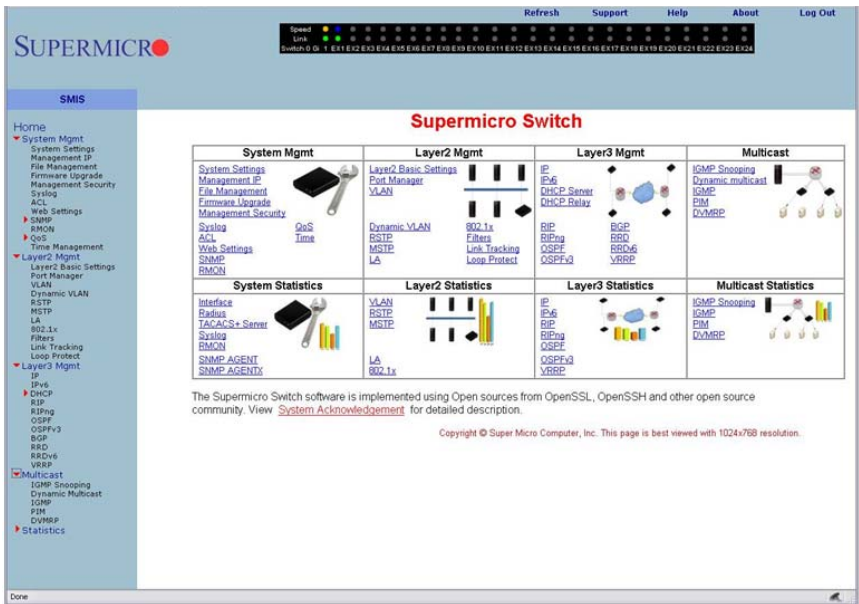

Figure 7-5. SSE-G24-TG4 Home Page

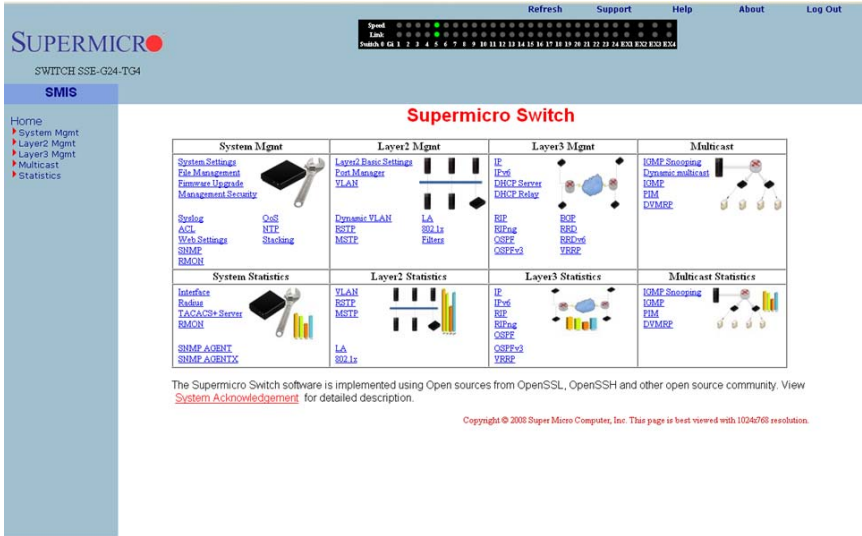
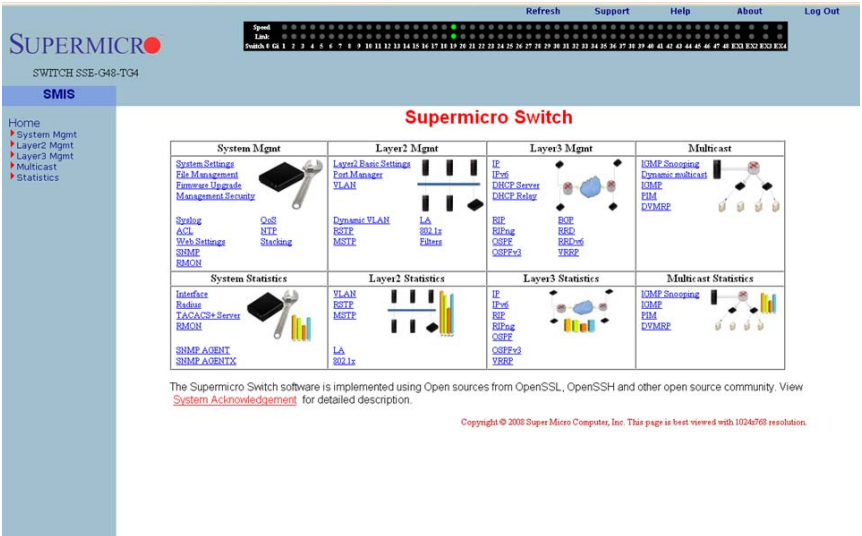

Figure 7-6. SSE-G48-TG4 Home Page



## Top Page Links

On the top of all pages of the web-based management utility you can find the following PAGE HEADER links:

- **Refresh** – Click this link to refresh the contents of the page. Unlike the browser refresh button, this link refreshes only the contents of the middle of the page which has the active data.
- **Support** – Click this link to get technical support for Supermicro Products.
- **Help** – Click on this link to open a context specific help page that covers all the items on the page being viewed.
- **About** – Click this link to get additional information about the web-based management utility, the switch and also the versions supported.
- **Log Out** – Click this link to log out of the web session and go back to the Login page.

## Top LED Display

This part of the screen displays the **Port Status**, **Speed** and **Link Status** for every port of the switch.

Since the number of ports is different in SBM-GEM-X2C(+), SSE-G24-TG4 and SSE-G48-TG4 switches, this display displays a different number of ports for each when the Web Management Utility is run:

- For the SBM-GEM-X2C switch, it displays sixteen Gigabit Ethernet (Gi) ports and three 10-Gigabit Ethernet (Ex - Extreme Ethernet) ports.
- For the SBM-GEM-X2C+ and SBM-GEM-X3S+ switches, it displays twenty-two Gigabit Ethernet (Gi) ports and three 10-Gigabit Ethernet (Ex - Extreme Ethernet) ports.
- For the SSE-G24-TG4 switch, it displays twenty four Gi ports and four Ex ports.
- For the SSE-G48-TG4 switch, it displays forty eight Gi ports and four Ex ports.

Note that Ex ports configured as stacking ports will not be displayed.

In stacking, the **Switch Identifier** will be displayed on top of this LED display. This allows you to select a stack member switch of interest, and to view the LED display for the corresponding switch.

For **Link**, a green light corresponding to a number indicates that numbered port is up, whereas a red light corresponding to a number indicates that this port is down.

## Left Side Tree

The tree display on the left side of the page provides quick access to the configuration pages. This tree is organized based on the features supported in the switch. The main features are categorized in the following groups.

- System Management - System based configurations
- Layer 2 Management - Layer 2 Protocols including VLAN, RSTP, MSTP, ...

- Layer 3 Management - Layer 3 Protocols including - IP, RIP, OSPF, ....
- Multicast Management - Multicast Protocols including IGMP, PIM, ...
- Statistics - Statistics and Counters for all the features.

This tree is displayed on the left navigation pane on all configuration pages. This makes it easier for you to choose any configuration page directly without going back to the home page every time. To go to one of a MANAGEMENT page's sub-pages, click on the ► symbol to expand the list.

## Middle Configuration Link Table

This section of the page displays a table of links to all major configurations. This table provides links similar to the Left Side Tree links. The configuration links are categorized based on features of the switch.

## 7-4 System Management Page

Figure 7-7. System Management Page

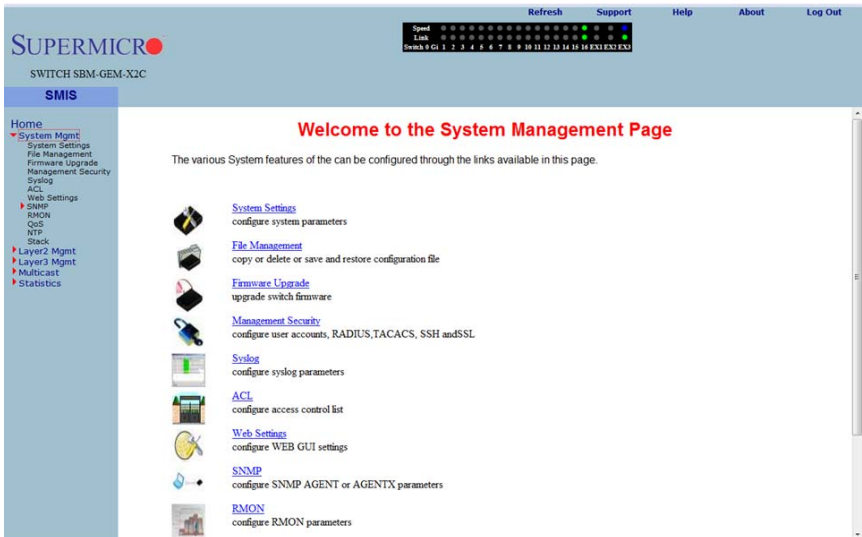

The SYSTEM MANAGEMENT page (Figure 7-7) contains the following links:

- "System Settings" on page 7-10
- "System Version" on page 7-12
- "File Management" on page 7-13
- "Firmware Upgrade" on page 7-15
- "Management Security" on page 7-16
- "Syslog" on page 7-25



- "ACL" on page 7-27
- "WEBGUI Settings" on page 7-31
- "SNMP" on page 7-32
- "RMON" on page 7-43
- "QoS" on page 7-48
- "NTP Settings" on page 7-53
- "Stack" on page 7-54

## System Settings

The following pages can be accessed through the System Settings link:

- "System Settings" on page 7-10
- "System Version" on page 7-12

### System Settings

Figure 7-8. System Settings Page

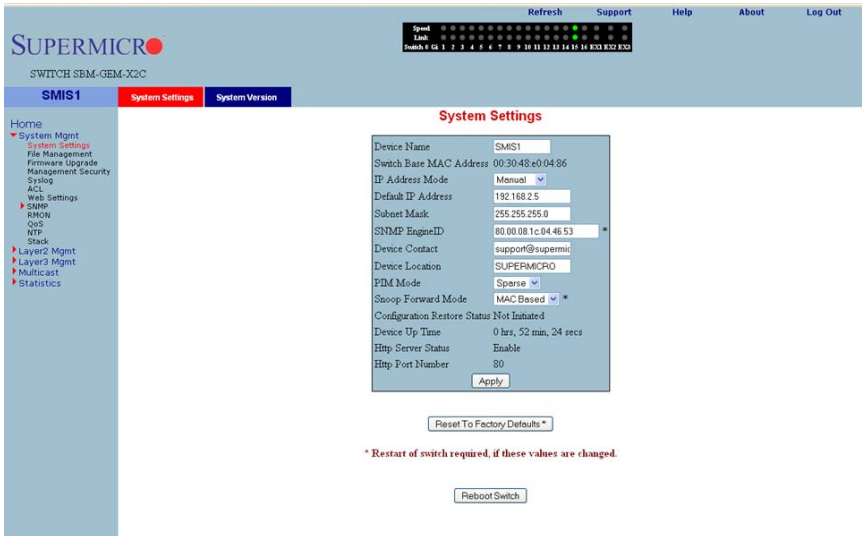

Clicking the SYSTEM INFORMATION tab brings up the SYSTEM SETTINGS page (Figure 7-8). This page provides system related information and also helps you configure system specific parameters. Table 7-2 lists the parameters found on this page.

Table 7-2. System Information Page Parameters

Parameter	Description
Device Name	A configurable name can be entered into this field for the switch.
IP address mode	Either Manual or Automatic mode can be set for this parameter.
Subnet Mask	Use this parameter to configure the subnet mask.
SNMP Engine ID	This configures the SNMP Engine Identifier.
Device contact	Use this parameter to change the device contact.
Device Location	Use this parameter to change the device location.
PIM Mode	Use this to configure the PIM status of the switch.

Table 7-2. System Information Page Parameters (Continued)

Parameter	Description
Snoop forwarding Mode	You can use this parameter to change the Snoop Forwarding Mode between MAC based and IP based.
Switch Start MAC address	This is a display for the Switch Start MAC address.
Configuration Restore Status	This is a display for the Configuration Restore Status
Device Up Time	This is a display for the Device Up Time.
HTTP Server Status	This is a display for the HTTP Server Status.
HTTP Port Number	This is a display for the HTTP Port Number.

This page also has a control to **Reset To Factory Defaults**. This clears all switch configuration and local user accounts information. This reset requires reboot of the switch.



**WARNING:** Make sure to have all necessary configurations backed up before doing "Reset To Factory Defaults.".

This page also provides a control to **Reboot** the switch. In stacking, the Switch Identifier is displayed on top of this reboot button. You can select the interested stack member switch to reboot the corresponding switch. You can also select the **ALL** option to reboot all stack members.

## System Version

Figure 7-9. System Version Page

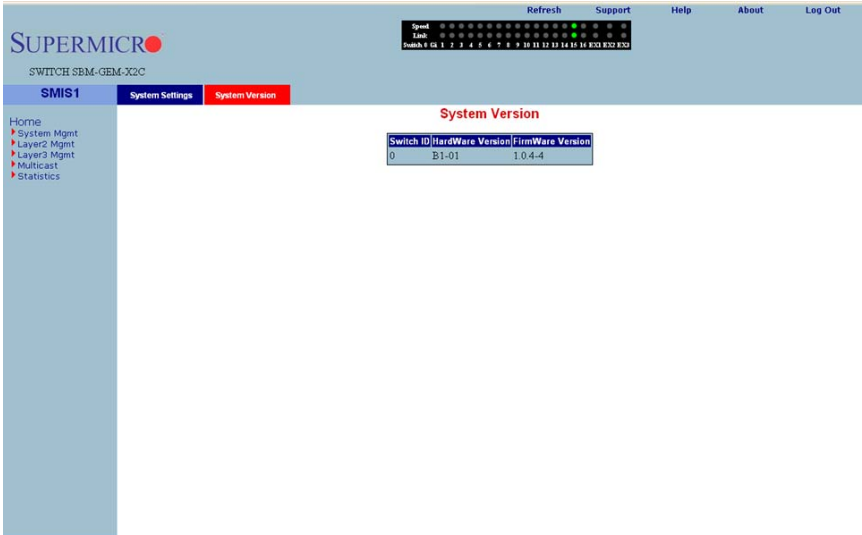

Clicking the SYSTEM VERSION tab brings up the SYSTEM VERSION page (Figure 7-9). This page displays the hardware and firmware version of the switch.

## File Management

Figure 7-10. File Management Page

The screenshot shows the SUPERMICR web interface for a switch (SMIS1). The main content area is divided into three sections:

- Save configuration:** Contains three radio buttons:  Save Startup Config,  Save Flash File, and  Save Remotely. A "Save" button is located below these options. Below the buttons, it displays "Total Space 4096 KB" and "Available Space 2572 KB".
- File Copy:** Contains two sections: "Source" and "Destination". Each section has radio buttons for  Local and  Remote, and a "File" input field. The "Source" field contains "param". A "Copy" button is at the bottom.
- File Management:** Contains a table with the following data:
 

<input type="checkbox"/>	File Name	Size	Last modified	Startup Config
<input type="checkbox"/>	param	18	Tue Oct 3 21:28:56 2000	<input type="radio"/>
<input type="checkbox"/>	nopreempt	18	En Nov 10 10:19:17 2000	<input type="radio"/>
<input type="checkbox"/>	para543	17	En Nov 10 10:11:51 2000	<input type="radio"/>

 Below the table are "Delete" and "Set Startup Config" buttons.

Clicking the FILE MANAGEMENT link brings up the FILE MANAGEMENT page (Figure 7-10). The FILE MANAGEMENT page helps you to manage the configuration files in the switch. This page provides three main features.

- Save Configuration
- File Copy
- File Management

### Save Configuration

You can save a currently running switch configuration in the following three ways:

- **Save Startup Config** - This option saves the currently running configuration in a local flash file with the file name configured as a "startup configuration" file.
- **Save Flash File** - This option saves the currently running configuration in local flash file with a user specified file name.
- **Save Remotely** - This option saves the currently running configuration into a remote TFTP server. You need to provide the IP address and file name of the TFTP server for this option.

The total configuration memory space and available free space are also displayed for your reference.

### ***File Copy***

You can copy a local file to or from a remote TFTP server. This feature is useful to create a backup of configuration files remotely, and also to download configuration files from remote computers to the switch. You need to provide a local file name and also the remote TFTP server's IP address and file name for this feature.

### ***File Management***

This section displays information about the configuration files stored in the switch and allows you to do any of the following actions:

- You can select one or more files and delete them.
- You can choose a Startup Configuration file from this file list.
- You can choose the FILE option and enter a name for a Startup Configuration file.
- You can also choose the NO RESTORE option for not loading any configuration files on the next reboot of the switch.

## Firmware Upgrade

Figure 7-11. Firmware Upgrade Page

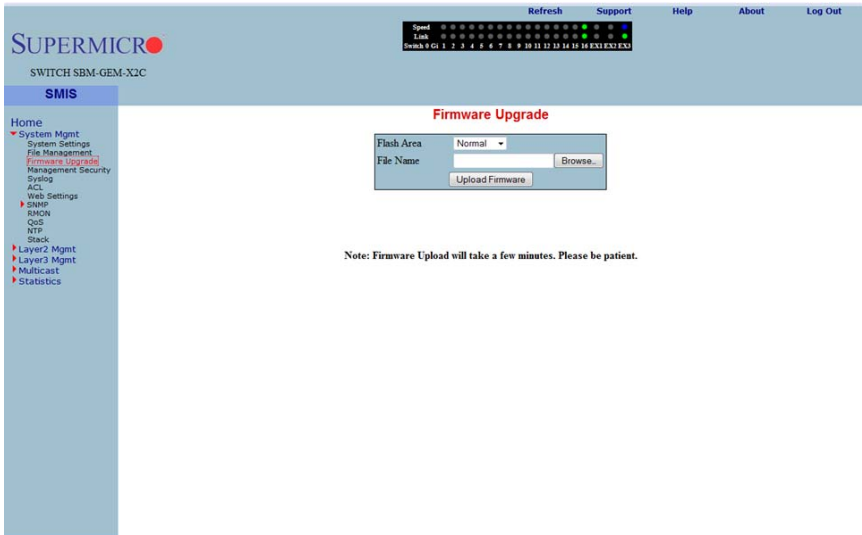

Clicking the FIRMWARE UPGRADE link brings up the FIRMWARE UPGRADE page (Figure 7-11). This page allows you to upgrade the firmware in normal or fallback memory. In stacking, the firmware is upgraded in all stack members automatically.

## Management Security

The MANAGEMENT SECURITY link provides configuration for the following features:

- "Management Security Basic Settings" on page 7-16
- "Management User Account" on page 7-17
- "Radius" on page 7-18
- "TACACS+ Global Settings" on page 7-19
- "TACACS+ Server Configuration" on page 7-20
- "IP Authorized Manager" on page 7-21
- "SSH Configuration" on page 7-22
- "SSL Configuration" on page 7-23

### Management Security Basic Settings

Figure 7-12. Management Security Basic Settings Page

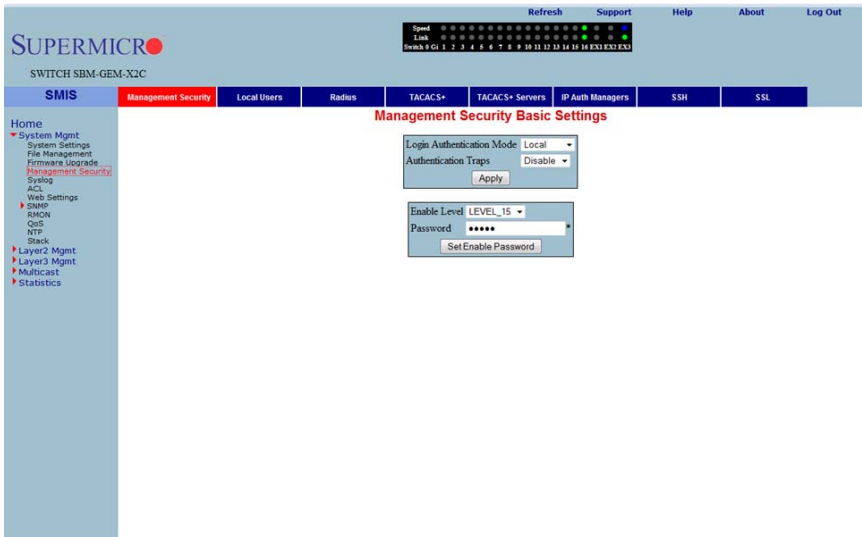

Clicking the MANAGEMENT SECURITY tab brings up the MANAGEMENT SECURITY BASIC SETTINGS page (Figure 7-12). This page allows you to setup the below listed basic security parameters (Table 7-3).



Table 7-3. Management Security Basic Settings Page Parameters

Parameter	Description
Authentication mode	Use this parameter to choose the mode of authentication for management access. By default the management access is authenticated with LOCAL user accounts information. However you can choose to authenticate using <i>Radius</i> or <i>TACACS</i> instead.
Authentication traps	You can enable SNMP Traps for SNMP access authentication events using this parameter..

Administrative users can also create *Enable Passwords* in this page. Low privilege users can use these Enable Passwords in the WEB SETTINGS page to enable access to privilege configurations.

Administrative users can set an *Enable Password* for all privilege levels. By default, the Enable Password is set only for the highest level (Level\_15). This default password is the same as the default password set for the ADMIN user login.

## Management User Account

Figure 7-13. Management User Account Page

The screenshot shows the 'Management User Account Configuration' page. The top navigation bar includes 'Refresh', 'Support', 'Help', 'About', and 'Log Out'. The main navigation tabs are 'SMIS', 'Management Security', 'Local Users', 'Radius', 'TACACS+', 'TACACS+ Servers', 'IP Auth Managers', 'SSH', and 'SSL'. The 'Local Users' tab is selected, showing a form to add a user with fields for 'User Name' (ADMIN), 'Password' (\*\*\*\*), and 'Privilege' (DEFAULT). Below the form is a table of existing users:

Select	User Name	Privilege
<input type="radio"/>	ADMIN	15
<input type="radio"/>	guest	1
<input type="radio"/>	stackuser	1

A 'Delete' button is located below the table.

Clicking the LOCAL USERS tab brings up the MANAGEMENT USER ACCOUNT CONFIGURATION page (Figure 7-13). This page allows you to create or delete local user accounts. You need more than privilege Level\_5 to view all pages and need more than privilege Level\_10 for changing the configurations. The highest, Level\_15, is for Administrator privilege.

**Radius**

**Figure 7-14. Radius Server Configuration Page**

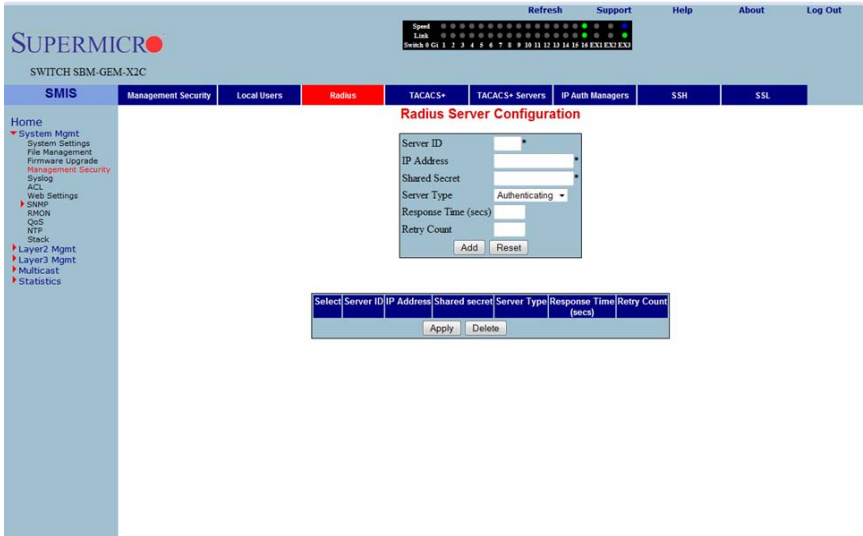

Clicking the RADIUS tab brings up the RADIUS SERVER CONFIGURATION page (Figure 7-14). This page allows you to configure the RADIUS server parameters as shown in Table 7-4.

**Table 7-4. Radius Server Configuration Page Parameters**

Parameter	Description
Server ID	This parameter specifies the unique identifier of the Radius Server Entry.
IP Address	This parameter specifies the IP Address of the Radius Server.
Shared Secret	Use this parameter to specify the secret string, which is to be shared between the Radius Server and the Radius Client.
Server Type	This parameter specifies the following RADIUS server type <ul style="list-style-type: none"> <li>• <i>Authentication</i></li> <li>• <i>Accounting</i></li> <li>• <i>Both (Authentication and Accounting).</i></li> </ul>
Response Time (secs)	This parameter specifies the maximum time that the Radius Server has to respond for a request from the Radius Client.
Retry Count	This parameter specifies the maximum number of times a radius request is re-transmitted before getting a response from the Radius Server.

## TACACS+ Global Settings

Figure 7-15. TACACS+ Global Settings Page

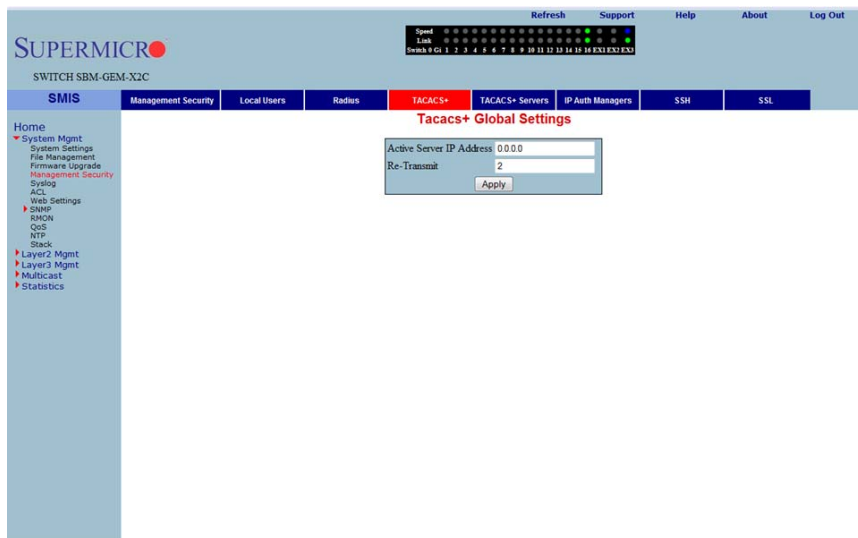

The TACACS+ GLOBAL SETTINGS page (Figure 7-15) allows you to configure TACACS retries and choose an active TACACS server. The parameters for this page are shown in Table 7-5.

Table 7-5. TACACS+ Global Settings Page Parameters

Parameter	Description
Active Server IP Address	This parameter specifies the IP address of the active TACACS server. This server should have been already configured in the following TACACS+ SERVER CONFIGURATION page (Figure 7-16).
Retries	This parameter determines the number of times the switch searches the active TACACS server from the list of servers maintained. The allowed values are between 1 to 100.

## TACACS+ Server Configuration

Figure 7-16. TACACS+ Server Configuration Page

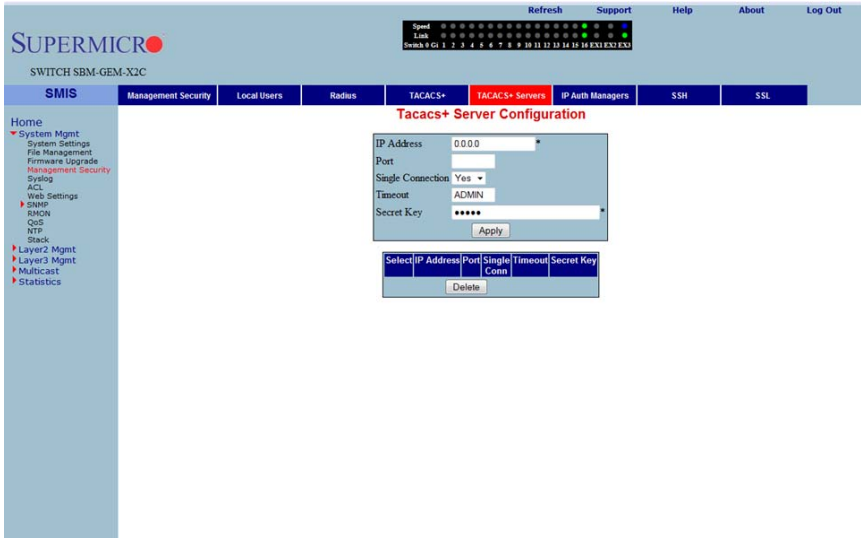

Clicking the TACACS+ SERVERS tab brings up the TACACS+ SERVER CONFIGURATION page (Figure 7-16), which allows you to configure TACACS servers. The parameters for this page are shown in Table 7-6.

Table 7-6. TACACS+ Server Configuration Page Parameters

Parameter	Description
IP Address	This parameter specifies the IP address of the TACACS server.
Port	Use this parameter to specify the TCP port for TACACS protocol.
Single Connection	Specify <i>Yes</i> or <i>No</i> for a single TCP connection. If <i>Yes</i> , it establishes only a single TCP connection with a given TACACS server.
Timeout	The time for which the switch will wait for a response from the TACACS server before closing the connection is specified with this parameter. It is configurable in seconds, with the default as <b>5-seconds</b> .
Secret Key	This parameter specifies the encryption key for the given TACACS server.

## IP Authorized Manager

Figure 7-17. IP Authorized Manager Page

The screenshot shows the 'IP Authorized Manager' configuration page. At the top, there is a status bar with 'Speed' and 'Link' indicators. Below that is a navigation menu with tabs for 'SMIS', 'Management Security', 'Local Users', 'Radius', 'TACACS+', 'TACACS+ Servers', 'IP Auth Managers', 'SSH', and 'SSL'. The 'IP Auth Managers' tab is active. The main content area is titled 'IP Authorized Manager' and contains a form with the following fields and options:

- IP Address:
- Subnet Mask:
- Port List (Incoming):
- VLANs Allowed:
- Services Allowed:  ALL  SNMP  TELNET  HTTP  HTTPS  SSH

At the bottom of the form, there are 'Add' and 'Reset' buttons. Below the form, a legend indicates: `[IP Address]` `[Subnet Mask]` `[Port List (Incoming)]` `[VLANs Allowed]` `[Services Allowed]`.

Clicking the IP AUTH MANAGER tab brings up the IP AUTHORIZED MANAGER page (Figure 7-17), which allows you to configure allowed management nodes for managing the switch. The parameters for this page are shown in Table 7-7.

Table 7-7. IP Authorized Manager Page Parameters

Parameter	Description
IP Address	This parameter specifies the IP address of the manager. An address <b>0.0.0.0</b> indicates "Any Manager".
Subnet Mask	This parameter specifies the sub-network mask for the specified IP address.
Port List (Incoming)	This lists the port through which the manager can access this switch. Ports can be comma separated or provided as a range (for example 1,2,3 or 1-3 or 1,2-3).
VLANs Allowed	This parameter specifies the VLANs through which the manager can access this switch. VLANs can be comma separated or provided as range (for example 1,2,3 or 1-3 or 1,2-3).
Services Allowed	These control buttons are used to indicate the service type, and can be one or more of the following: TELNET, SSH, HTTP, HTTPS, SNMP or ALL.

## SSH Configuration

Figure 7-18. SSH Configuration

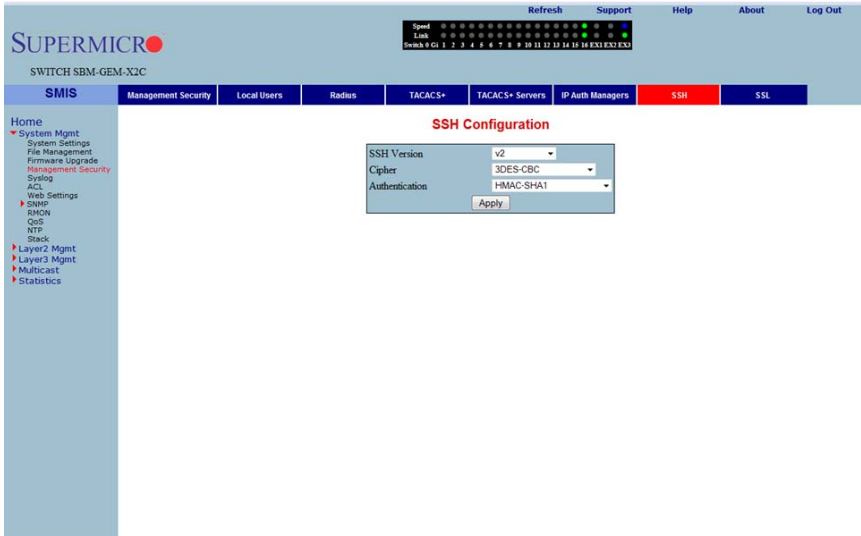

Clicking the SSH tab brings up the SSH CONFIGURATION page (Figure 7-18), which allows you to configure the SSH (Secure Shell) version and keys. The parameters for this page are shown in Table 7-8.

Table 7-8. SSH Configuration Page Parameters

Parameter	Description
SSH Version	The default for this parameter is <b>v2</b> . You can choose to configure this as compatible with <b>v1</b> instead.
Cipher	The default for this parameter is <b>3DES-CBC</b> . You can instead choose to configure it as <b>3DES-CBC</b> or <b>DES-CBC</b> or both
Authentication	This parameter's default is <b>HMAC-SHA1</b> . You can instead choose to configure it as <b>HMAC-SHA1</b> or <b>HMAC-MD5</b> or both.

## SSL Configuration

Figure 7-19. SSL Configuration Page

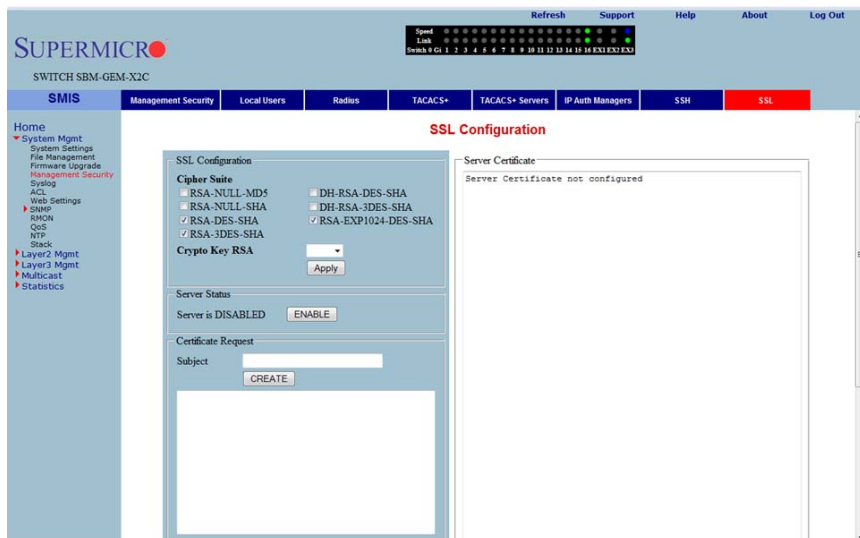

Clicking the SSL tab brings up the SSL CONFIGURATION page (Figure 7-19), which allows you to configure SSL (Secure Sockets Layer) parameters and generate SSL certificates for HTTPS. To configure SSL and enable HTTPS, follow the procedure below using this page.

### Configuring SSL and Enabling HTTPS

1. Configure CIPHER SUITE and CRYPTO KEY RSA with your chosen parameters.
2. Create a certificate request by entering the subject name and clicking on the CREATE button.
3. When the page reloads, the text box below the CREATE button will display a certificate request. Copy and paste these contents to a text file that says **a.csr**.
4. To generate an SSL certificate, the **openssl** application can be used. The sub-steps below can be executed in any Linux machine to generate SSL certificates. For other *openssl* implementations, refer to the *openssl* documentation to find the equivalent steps for them.
  - a. Execute the below command in the Linux shell.
 

```
openssl req -x509 -newkey rsa:1024 -keyout cakey.pem
-out cacert.pem
```
  - b. Execute the below command also in a Linux shell.

```
openssl x509 -req -in a.csr -out cert.pem -CA cacert.pem  
-CAkey cakey.pem -CAcreateserial
```

The above steps will generate the certificate file **cert.pem**.

5. Open the generated certificate file *cert.pem* and delete the first line (---BEGIN CERTIFICATE ---) and last line (---END CERTIFICATE--).
6. Join all the remaining lines as single lines to avoid line breaks being processed and copy/paste these joined texts in the ENTER CERTIFICATE text box back in the SSL CONFIGURATION page.
7. Click the CONFIGURE button.

This configures the certificate and saves it to flash memory.



## Syslog

The Syslog link provides configuration controls for the following features:

- "Syslog Configuration" on page 7-25
- "Syslog Mail Configuration" on page 7-26

### Syslog Configuration

Figure 7-20. Syslog Configuration Page

Syslog	Console Logging	Timestamp Logging	Trap Logging	Facility	Server IP	Buffer Size
Enabled	Enabled	Enabled	Debugging	local0	0.0.0.0	50

Clicking the LOGGING tab brings up the SYSLOG CONFIGURATION page (Figure 7-20), which allows you to configure logging parameters. The parameters for this page are shown in Table 7-9.

Table 7-9. Syslog Configuration Page Parameters

Parameter	Description
Syslog	This parameter enables or disables the Syslog feature.
Server IP Address	This parameter specifies the Syslog server IP address. Make sure the Server IP is reachable.
Buffer Size	The buffer size is specified in log entries. Max entries buffered is <b>200</b> .
Timestamp	This parameter allows you to enable or disable the adding of a timestamp to the log messages.
Console Log	This parameter allows you to enable or disable logging to the console.

**Table 7-9. Syslog Configuration Page Parameters (Continued)**

Parameter	Description
Facility	This parameter allows you to select supported facilities. The switch supports syslog standard supported facilities LOCAL0, LOCAL1, LOCAL2, LOCAL3, LOCAL4, LOCAL5, LOCAL6, LOCAL7 and USER.
Traps	This parameter helps you to select a particular trap type. The following types of traps are supported ALERTS, CRITICAL, DEBUGGING, EMERGENCIES, ERROR, INFORMATIONAL, NOTIFICATION and WARNINGS.

### Syslog Mail Configuration

**Figure 7-21. Syslog Mail Configuration Page**



Clicking the MAIL tab brings up the SYSLOG MAIL CONFIGURATION page (Figure 7-21), which allows you to configure the mail server and mail addresses for the syslog feature. The parameters for this page are shown in Table 7-10.

**Table 7-10. Syslog Mail Configuration Page Parameters**

Parameter	Description
Mail Server IP Address	This parameter specifies the IP address of the mail server. Make sure the mail server is reachable.
Sender Email ID	This parameter specifies the Email ID to be shown as the From address on Syslog Emails.
Receiver Email ID	This parameter specifies the receipt Email address for Syslog Emails.

## ACL

The ACL link allows you to configure the Access Control List for the switch. You can configure ACL on the following three pages:

- "MAC Based ACL" on page 7-27
- "IP Standard ACL" on page 7-28
- "IP Extended ACL" on page 7-29

### MAC Based ACL

Figure 7-22. MAC ACL Configuration Page

The screenshot shows the 'MAC ACL Configuration' page. The navigation menu on the left includes 'Home', 'System Mgmt', 'System Settings', 'File Management', 'Firmware Upgrade', 'Management Security', 'Syslog', 'ACL', 'Web Settings', 'SNMP', 'RMON', 'QoS', 'NTP', 'Stack', 'Layer2 Mgmt', 'Layer3 Mgmt', 'Multicast', and 'Statistics'. The 'MAC ACL' tab is selected. The configuration form includes the following fields:

- ACL Number:
- Source MAC:
- Destination MAC:
- Action:
- Priority:
- VLAN ID:
- Port List (Incoming):
- Encapsulation:
- Protocol:

Buttons for 'Add' and 'Reset' are located below the form. Below the form is a table with the following columns:

Select	Number	Source MAC	Destination MAC	Action	Priority	VLAN ID	Port List (Incoming)	Encapsulation	Protocol	Protocol Number

Clicking the MAC ACL tab brings up the MAC ACL CONFIGURATION page (Figure 7-22), which displays the various parameters to configure the MAC Access List. The parameters for this page are shown in Table 7-11.

Table 7-11. MAC ACL Configuration Page Parameters

Parameter	Description
ACL Number	This parameter specifies a unique ID for the access list.
Source and Destination MAC	These fields specify both the Source MAC Address and Destination MAC Address, for which the access list must be applied. Both the Source and Destination MAC Addresses must be configured for the status of the access list to be active.

**Table 7-11. MAC ACL Configuration Page Parameters (Continued)**

Parameter	Description
Action	This parameter specifies the action to be taken for the access list.
Priority	This parameter specifies the priority for the access list.
VLAN ID	This parameter specifies the VLAN ID for which the access list has to be applied.
Port List (Incoming)	This parameter specifies the Port List for which the access list has to be applied.
Encapsulation	This parameter specifies the Encapsulation type of the packet for which the access list has to be applied.
Protocol	This parameter specifies the non-IP protocol type of the packet for which the access list has to be applied.

### IP Standard ACL

**Figure 7-23. IP Standard ACL Configuration Page**

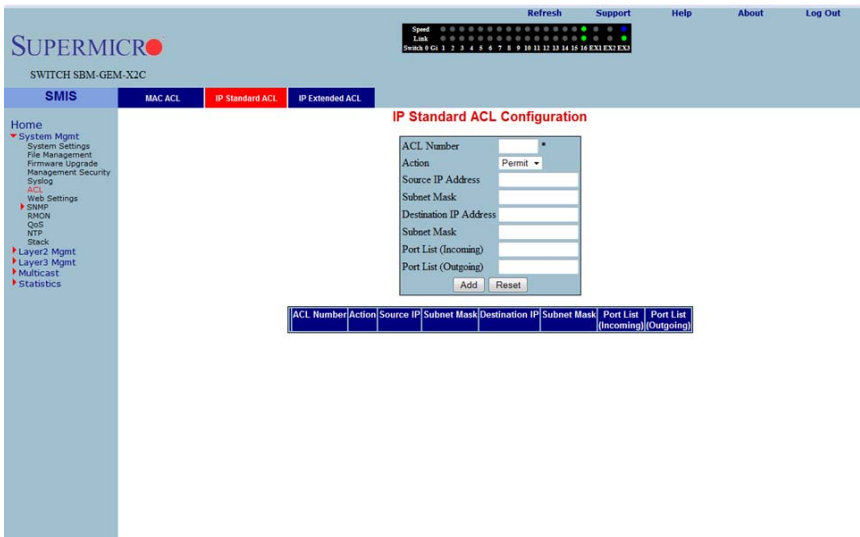

Clicking the IP STANDARD ACL tab brings up the IP STANDARD ACL CONFIGURATION page (Figure 7-23), which displays the various ACL (Access Control List) parameters to configure the Standard IP access lists. The parameters for this page are shown in Table 7-12.

Table 7-12. IP Standard ACL Configuration Page Parameters

Parameter	Description
ACL Number	This parameter specifies the unique ID for the access list. This value must be in the range from 1 to 1000.
Action	This parameter specifies whether the packets must be allowed or dropped when a match has been found.
Source and Destination IP Address	This parameter specifies the IP Address of the Source and Destination for which the access list must be applied.
Subnet Mask	This parameter specifies the Source and Destination Address Mask corresponding to the IP Address.
Ports List (Incoming)	This parameter specifies the Incoming Port List for which the access list has to be applied.
Ports List (Outgoing)	This parameter specifies the Outgoing Port List for which the access list has to be applied.

## IP Extended ACL

Figure 7-24. IP Extended ACL Page

The screenshot displays the 'IP Extended ACL Configuration' page. The interface includes a navigation menu on the left with options like 'Home', 'System Mgmt', 'System Settings', 'File Management', 'Firmware Upgrade', 'Management Security', 'Status', 'ACL', 'Web Settings', 'SNMP', 'RMON', 'QoS', 'NTP', 'Stack', 'Layer2 Mgmt', 'Layer3 Mgmt', 'Multicast', and 'Statistics'. The main content area is titled 'IP Extended ACL Configuration' and contains the following fields:

- ACL Number: \*
- Action: Permit
- Source IP Address: [Text Field]
- Subnet Mask: [Text Field]
- Destination IP Address: [Text Field]
- Subnet Mask: [Text Field]
- Port List (Incoming): [Text Field]
- Port List (Outgoing): [Text Field]
- Protocol: icmp
- Message Code: 255
- Message Type: 255
- Priority: [Text Field]
- Discp: [Text Field]
- TOS: 1
- ACK Bit: Establish
- RST Bit: Set
- Source Port (Min): [Text Field] Source Port (Max): [Text Field]
- Destination Port (Min): [Text Field] Destination Port (Max): [Text Field]

Buttons for 'Add' and 'Reset' are located below the port range fields. A note states: 'Note : Range for Both Source and Destination Ports cannot be given.' At the bottom, a table header is visible with columns: Select, Filter, Action, Source, Subnet, Destination, Port List, Protocol, Other, Code, Type, Priority, Discp, TOS, ACK, RST, Source Port, and Destination Port.

Clicking the IP EXTENDED ACL tab brings up the IP EXTENDED ACL CONFIGURATION page (Figure 7-24), which displays the various parameters required to configure the Extended IP access lists. The parameters for this page are shown in Table 7-13.

**Table 7-13. IP Extended ACL Configuration Page Parameters**

Parameter	Description
ACL Number	This parameter specifies the unique ID for the access list. This value must be in the range from 1001 to 65535.
Action	This parameter specifies whether the packets must be allowed or dropped when a match has been found.
Source and Destination IP Address	This parameter specifies the IP Address for which the access list must be applied.
Subnet Mask	This parameter specifies the Address Mask corresponding to the IP Address.
Ports List (Incoming)	This parameter specifies the Incoming Port List for which the filter has to be applied.
Ports List (Outgoing)	This parameter specifies the Outgoing Port List for which the filter has to be applied.
Protocol	This parameter specifies the type of protocol.
Message Code	This parameter specifies the Message Code to be checked for ICMP Packets.
Message Type	This parameter specifies the Message Type to be checked for ICMP Packets.
Priority	This parameter specifies the Priority for the filter.
TOS	This parameter specifies the Type of Service for the access list.
ACK Bit	This parameter indicates the TCP Ack Bit to be checked against the incoming packet.
RST Bit	This parameter indicates the TCP Reset Bit to be checked against the incoming packet.
Source Port (Min)	These parameters specify the range of TCP/UDP sourceports from which the access list must be applied.
Source Port (Max)	
Destination Port (Min)	These parameters specify the destination ports to which the access list must be applied
Destination Port (Max)	

## WEBGUI Settings

Figure 7-25. Web GUI Settings Page

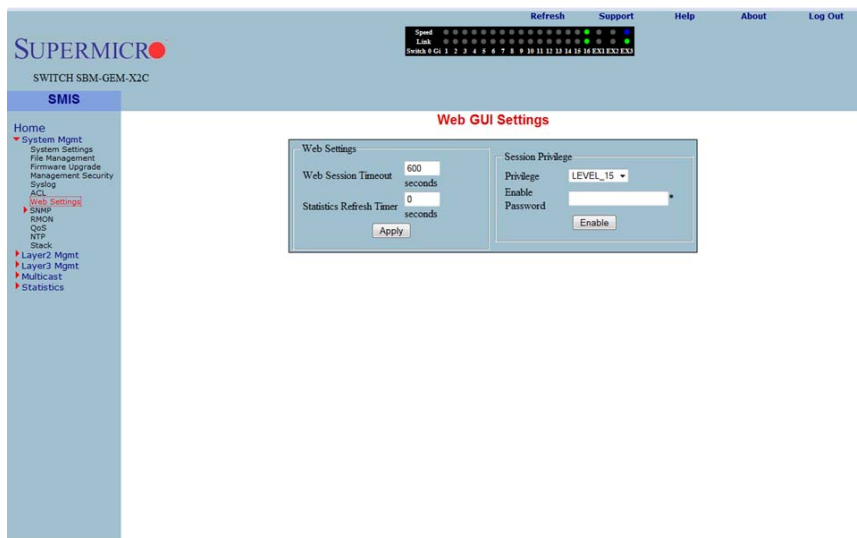

Clicking the WEB SETTINGS link brings up the WEB GUI SETTINGS page (Figure 7-25), which displays all basic Web GUI settings. The parameters for this page are shown in Table 7-14.

Table 7-14. Web GUI Settings Page Parameters

Parameter	Description
Session timeout	This timeout value is used to automatically logout inactive user sessions. The default value is <b>5-minutes</b> (600-seconds).
Statistics Refresh Timer	The statistics pages (grouped under "Statistics" node in left side tree) can be set to auto refresh based on this Statistics Refresh Timer. The default value <b>zero</b> means no auto refresh by default.
Session Privilege	This displays the current privilege level of the logged in user. You can choose to enter another privilege level using this configuration if you have the Enable Password for the required privilege levels. The Enable Passwords for different levels are configurable in the <a href="#">Management Security</a> web page.

## SNMP

Figure 7-26. SNMP Agent Control Settings Page

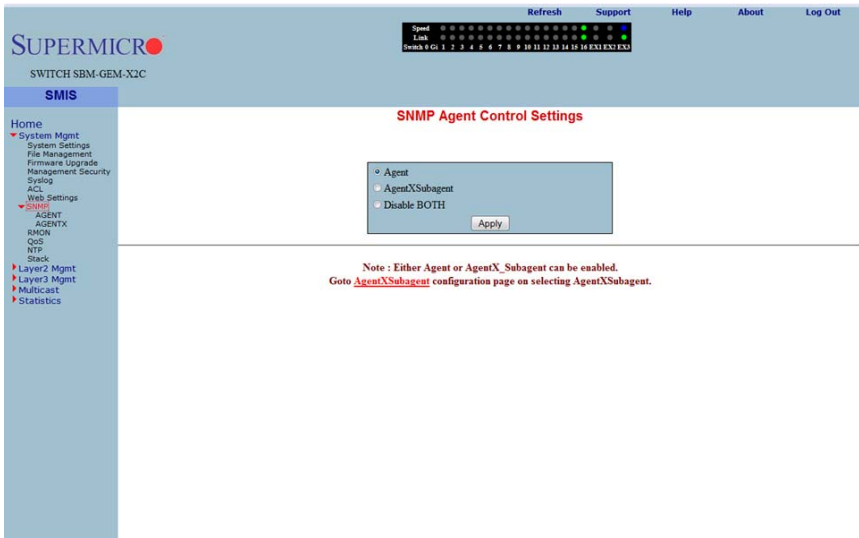

Clicking the SNMP link brings up the SNMP AGENT CONTROL SETTINGS page (Figure 7-26). SMIS supports the **SNMP Agent** or **SNMP AgentX Sub-agent**. The SNMP Agent or AgentX Sub-agent can be enabled or both can be disabled.

The SNMP Agent provides the following sub-page configurations shown in the table below.

Table 7-15. SNMP Agent Configuration Pages

Configuration Page	Description
<a href="#">"SNMP Community Settings" on page 7-33</a>	This page allows you to configure the SNMP community including the COMMUNITY INDEX, NAME, SECURITY NAME, CONTEXT NAME, TRANSPORT TAG and STORAGE TYPE.
<a href="#">"SNMP Group Settings" on page 7-34</a>	This page allows you to configure SNMP groups including GROUP NAME, SECURITY NAME, SECURITY MODEL and STORAGE TYPE.
<a href="#">"SNMP Group Access Settings" on page 7-35</a>	This page allows you to configure access parameters for SNMP groups including GROUP NAME, SECURITY MODEL, SECURITY LEVEL, STORAGE TYPE, and READ, WRITE and NOTIFY VIEW.
<a href="#">"SNMP View Tree Settings" on page 7-36</a>	This page allows you to configure an SNMP view tree including VIEW NAME, SUB TREE, MASK, TYPE OF THE VIEW and STORAGE TYPE.
<a href="#">"SNMP Target Address Settings" on page 7-37</a>	This page allows you to configure SNMP target including TARGET NAME, TARGET IP, TRANSPORT TAG, PARAM and STORAGE TYPE.

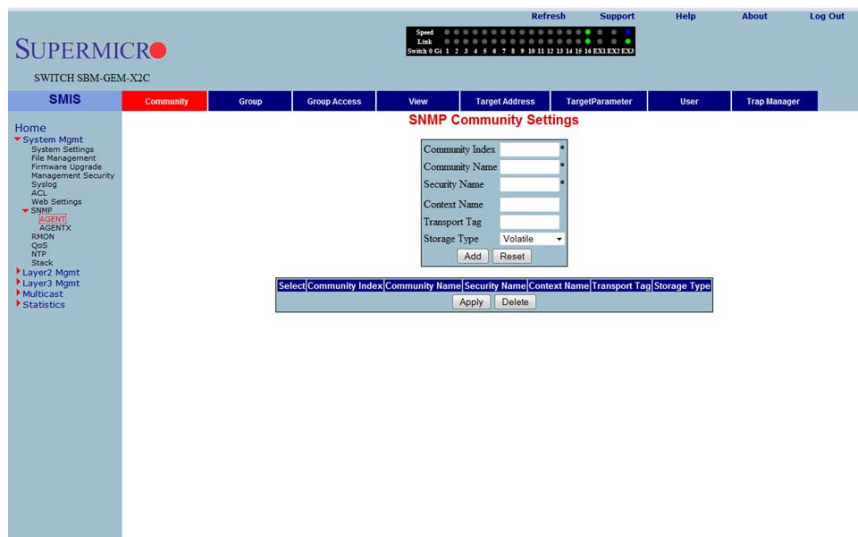

Table 7-15. SNMP Agent Configuration Pages (Continued)

Configuration Page	Description
"SNMP Target Parameter Settings" on page 7-38	This setting allows you to configure SNMP target parameters including PARAMETER NAME, MP MODEL, SECURITY MODEL, NAME, LEVEL and STORAGE TYPE.
"SNMP User Settings" on page 7-39	This setting allows you to configure SNMP security including user name, AUTHENTICATION PROTOCOL, AUTHENTICATION KEY, PRIVACY PROTOCOL, PRIVACY KEY and STORAGE TYPE.
"SNMP Trap Settings" on page 7-40	This setting allows you to configure SNMP trap notifications including NOTIFY NAME, NOTIFY TAG, NOTIFY TYPE and STORAGE TYPE.

## SNMP Community Settings

Figure 7-27. SNMP Community Settings Page



Clicking the COMMUNITY tab brings up the SNMP COMMUNITY SETTINGS page (Figure 7-27), which allows you to add SNMP managers or remove existing managers.. The parameters for this page are shown in Table 7-16.

Table 7-16. SNMP Community Settings Page Parameters

Parameter	Description
Community index	This parameter sets the COMMUNITY INDEX identifier.
Community name	This parameter sets the COMMUNITY NAME string.
Security Name	This parameter sets the User Name String.

**Table 7-16. SNMP Community Settings Page Parameters (Continued)**

Parameter	Description
Context Name	This parameter sets the CONTEXT NAME that the management information is accessed from when using the community string, which is specified by the corresponding instance of the SNMP community name.
Transport Tag	This parameter sets the TRANSPORT TAG Identifier.
Storage Type	This parameter sets the <i>Volatile Storage</i> or <i>Non-Volatile Storage</i> setting.

### SNMP Group Settings

**Figure 7-28. SNMP Group Settings Page**

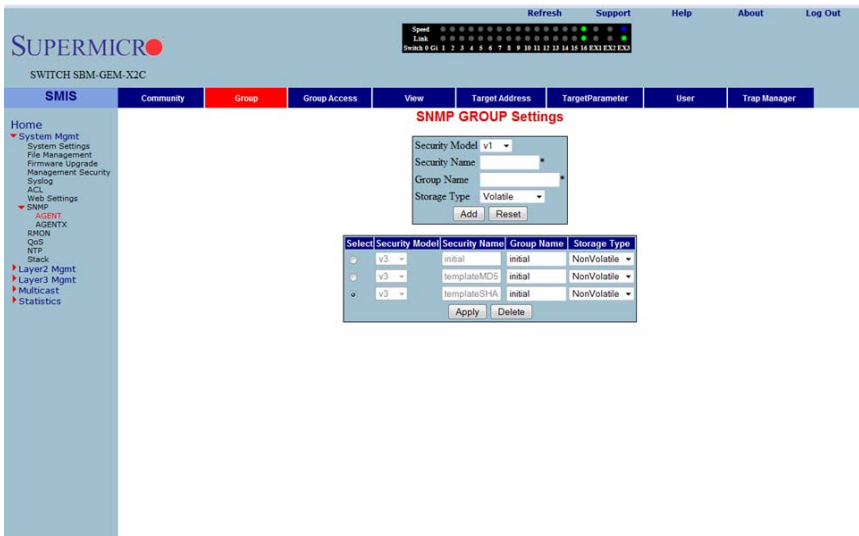

Clicking the GROUP tab brings up the SNMP GROUP SETTINGS page (Figure 7-28). This page helps you map a combination of the SECURITY MODEL and the SECURITY NAME into a GROUP NAME, which is used to define an access control policy. In addition, this page displays the STORAGE TYPE of the Group Table. The parameters for this page are shown in Table 7-17.

**Table 7-17. SNMP Group Settings Page Parameters**

Parameter	Description
Security Model	This parameter allows you to select from <i>version 1</i> , <i>version 2</i> or <i>version 3</i> for the SECURITY MODEL used.
Security Name	Use this parameter to specify the SECURITY NAME string.

Table 7-17. SNMP Group Settings Page Parameters (Continued)

Parameter	Description
Group Name	Use this parameter to specify the GROUP NAME string.
Storage Type	Use this parameter to specify whether the STORAGE TYPE is <i>Volatile</i> or <i>Non-Volatile</i> .

## SNMP Group Access Settings

Figure 7-29. SNMP Group Access Settings Page

The screenshot displays the 'SNMP Group Access Settings' page. At the top, there are navigation tabs: SMIS, Community, Group, Group Access (selected), View, Target Address, TargetParameter, User, and Trap Manager. A sidebar on the left shows a menu with options like Home, System Mgmt, System Settings, File Management, Firmware Upgrade, Management Security, Snmp, ACL, Web Settings, AGENT, AGENTX, RMON, QoS, NTP, Stack, Layer2 Mgmt, Layer3 Mgmt, Multicast, and Statistics. The main content area shows a form for 'SNMP Group Access Settings' with the following fields: Group Name (v1), Security Model (v1), Security Level (NoAuthentication), Read View, Write View, Notify View, and Storage Type (Volatile). Below the form is a table with the following data:

Select	Group Name	Context Prefix	Security Model	Security Level	Read View	Write View	Notify View	Storage Type
<input type="radio"/>	initial		v3	NoAuthentication	restricted	restricted	restricted	NonVolatile
<input type="radio"/>	initial		v3	Authentication	iso	iso	iso	NonVolatile
<input type="radio"/>	initial		v3	Private	iso	iso	iso	NonVolatile

Clicking the GROUP ACCESS tab brings up the SNMP GROUP ACCESS SETTINGS page (Figure 7-29), which displays the access rights of groups. Each entry is indexed by a GROUP NAME, a Context Prefix, a SECURITY MODEL and a SECURITY LEVEL. A proper view name (READ, WRITE and MODIFY) must be used for access control checking. It also displays the STORAGE TYPE of the Group Access table. An SNMP Group must be created prior to the Group Access configuration.

The parameters for this page are shown in Table 7-18.

Table 7-18. SNMP Group Access Settings Page Parameters

Parameter	Description
Group Name	This parameter allows you to specify the GROUP NAME string.
Security Model	This parameter allows you to specify whether SNMP <i>version v1, v2 or v3</i> is used. <i>Version 3</i> is the most secure model as it allows packet encryption with the private key word.

**Table 7-18. SNMP Group Access Settings Page Parameters (Continued)**

Parameter	Description
Security Level	With this parameter the no-authentication option disables authentication. The AUTHENTICATION option enables <i>Message digest (MD5)</i> or <i>Secure Hash Algorithm (SHA)</i> packet authentication. The PRIVATE option selects both AUTHENTICATION and PRIVACY.
Read View	This parameter allows you to specify the READ VIEW identifier.
Write View	This parameter allows you to specify the WRITE VIEW identifier.
Notify View	This parameter allows you to specify the NOTIFY VIEW identifier.
Storage Type	Use this parameter to specify whether the STORAGE TYPE is <i>Volatile</i> or <i>Non-Volatile</i> .

**SNMP View Tree Settings**

**Figure 7-30. SNMP View Tree Settings Page**

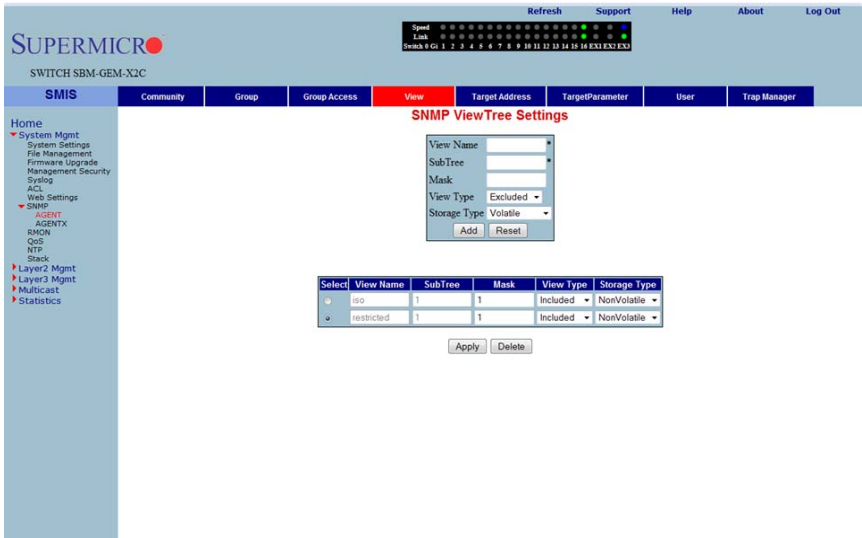

Clicking the VIEW tab brings up the SNMP VIEW TREE SETTINGS page (Figure 7-30), which allows configuration of view trees. A SUBTREE when combined with the corresponding instance of a MASK defines a family of view subtrees. The VIEW NAME is the name for a family of view subtrees. This page also displays the STORAGE TYPE of the VIEWTREE table. SNMP Group and SNMP Access settings have to be created prior to the Group View configuration.

The parameters for this page are shown in Table 7-19.

Table 7-19. SNMP View Tree Settings Page Parameters

Parameter	Description
View Name	This parameter specifies a VIEW NAME string.
SubTree	This parameter specifies a tree OID.
Mask	This parameter specifies an OID mask.
View Type	This parameter specifies whether a VIEW TYPE is <i>Included</i> or <i>Excluded</i> .
Storage Type	Use this parameter to specify whether the STORAGE TYPE is <i>volatile</i> or <i>non-volatile</i> .

### SNMP Target Address Settings

Figure 7-31. SNMP Target Address Settings Page

The screenshot shows the SUPERMICR web interface for a SWITCH SBM\_GEM\_X2C. The 'SNMP' tab is selected in the navigation menu. The 'SNMP Target Address Settings' page is displayed, featuring a form with the following fields and values:

- Target Name: (empty)
- Target IP Address: (empty)
- Target Timeout: 1500
- Target Retries: 3
- Transport Tag: (empty)
- Param: (empty)
- Storage Type: Volatile

Buttons for 'Add' and 'Reset' are located below the form. At the bottom of the page, a table lists the columns for the settings page:

Select	Target Name	Target IP Address	Timeout	Retries	Transport Tag	Param	Storage Type

'Apply' and 'Delete' buttons are positioned below the table.

Clicking the TARGET ADDRESS tab brings up the SNMP TARGET ADDRESS SETTINGS page (Figure 7-31), which configures SNMP target address parameters. The parameters for this page are shown in Table 7-20.

Table 7-20. SNMP Target Address Settings Page Parameters

Parameter	Description
Target Name	This parameter specifies a TARGET NAME as a unique identifier.
Target IP Address	The TARGET IP ADDRESS specifies a target address to be used in the generation of SNMP operations.

**Table 7-20. SNMP Target Address Settings Page Parameters (Continued)**

Parameter	Description
Target Timeout	TARGET TIMEOUT specifies the maximum round trip for communicating with the TARGET IP ADDRESS.
Target Retries	TARGET RETRIES specifies the number of attempts to be made when no response is received
Transport Tag	The TRANSPORT TAG value is used to select a target address for a particular operation.
Param	PARAM contains SNMP parameters to be used when generating messages to be sent to a transport address.
Storage Type	Use this parameter to specify whether the STORAGE TYPE is <i>volatile</i> or <i>non-volatile</i> .

**SNMP Target Parameter Settings**

**Figure 7-32. SNMP Target Parameter Settings Page**

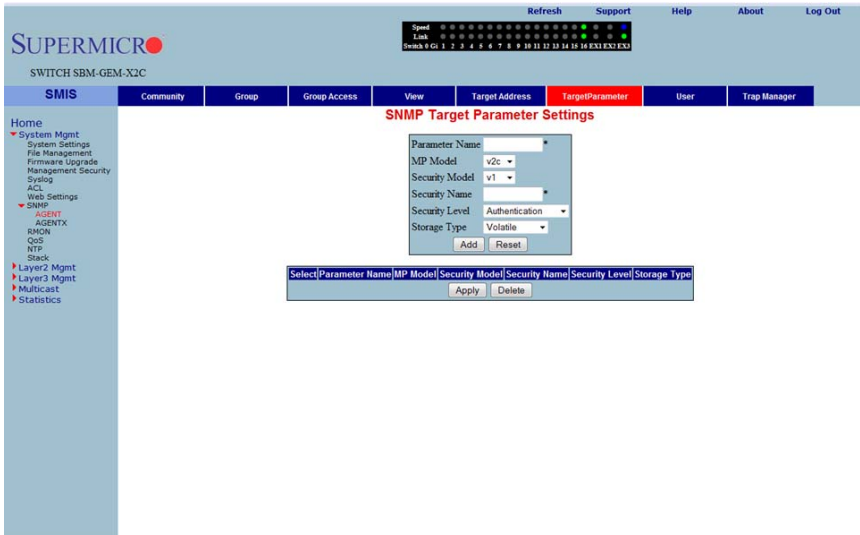

Clicking the TARGET PARAMETER tab brings up the SNMP TARGET PARAMETER SETTINGS page (Figure 7-32), which configures SNMP Target Address parameters. The parameters for this page are shown in Table 7-21.

Table 7-21. SNMP Target Parameter Settings Page Parameters

Parameter	Description
Parameter Name	The target parameter is a unique name that specifies SNMP target information to be used in the generation of SNMP messages.
MP Model	The Message Processing (MP) Model is used when generating SNMP messages using this entry.
Security Model	The SECURITY MODEL is used when generating SNMP messages using this entry.
Security Name	The SECURITY NAME identifies the current PARAMETER NAME, on whose behalf SNMP messages will be generated.
Security Level	SECURITY LEVEL specifies the level of security used when generating SNMP messages.
Storage Type	STORAGE TYPE can be configured as <i>Volatile</i> or <i>Non-Volatile</i> .

## SNMP User Settings

Figure 7-33. SNMP Security Settings Page

The screenshot displays the 'SNMP Security Settings' page. At the top, there is a status bar with 'Speed' and 'Link' indicators. Below that, the 'SUPERMICR' logo and 'SWITCH SBM-GEM-X2C' are visible. The main navigation bar includes 'SMIS', 'Community', 'Group', 'Group Access', 'View', 'Target Address', 'Target Parameter', 'User', and 'Trap Manager'. The 'User' tab is active. The page title is 'SNMP Security Settings'. The form contains the following fields:

- User Name:
- Authentication Protocol:
- Authentication Key:
- Privacy Protocol:
- Privacy Key:
- Storage Type:

Buttons for 'Add' and 'Reset' are located below the form. At the bottom, a table with the following columns is shown:

Select	Engine Id	User Name	Authentication Protocol	Private Protocol	Storage Type

'Apply' and 'Delete' buttons are positioned below the table.

Clicking the USER tab brings up the SNMP SECURITY SETTINGS page (Figure 7-33), which configures users configured in the SNMP for the User-based Security Model. The parameters for this page are shown in Table 7-22.

**Table 7-22. SNMP Security Settings Page Parameters**

Parameter	Description
User Name	USER NAME is the (User-based Security) model dependent security ID.
Authentication Protocol	The AUTHENTICATION PROTOCOL is used for authentication.
Authentication Key	The AUTHENTICATION KEY is the secret authentication key used for messages sent on behalf of this user to/from the SNMP.
Privacy Protocol	PRIVACY PROTOCOL is an indication of whether or not messages sent on behalf of this user to/from the SNMP are protected from disclosure, and if so, the type of privacy protocol that is used.
Privacy Key	PRIVACY KEY is an indication of whether or not messages sent on behalf of this user to/from the SNMP are protected from disclosure.
Storage Type	STORAGE TYPE can be configured as <i>Volatile</i> or <i>Non-Volatile</i> .

**SNMP Trap Settings**

**Figure 7-34. SNMP Trap Settings Page**

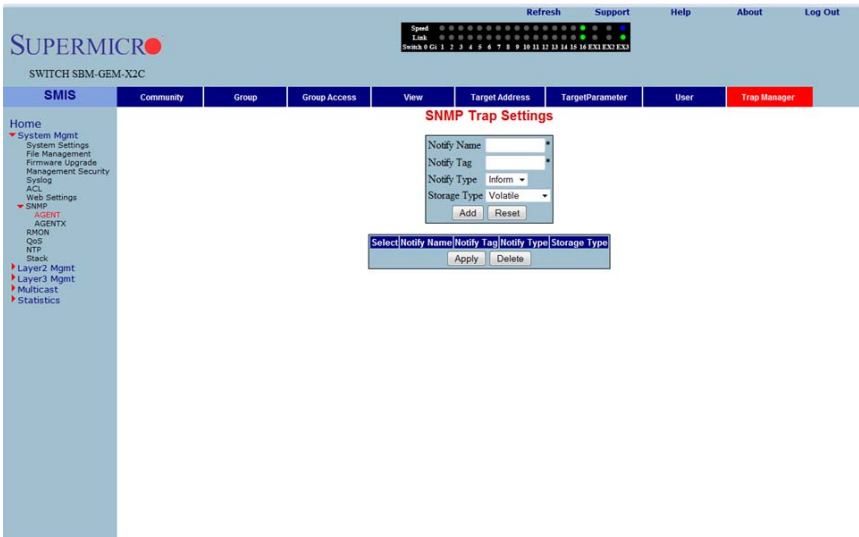

Clicking the TRAP MANAGER tab brings up the SNMP TRAP SETTINGS page (Figure 7-34), which configures the set of management targets that must receive notifications. The parameters for this page are shown in Table 7-23.

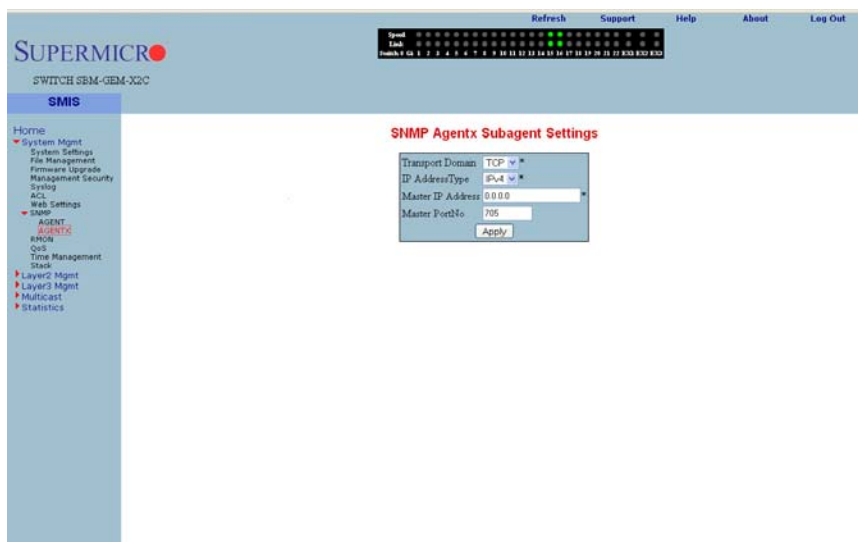

Table 7-23. SNMP Trap Settings Page Parameters

Parameter	Description
Notify Name	NOTIFY NAME is a unique identifier associated with the entry.
Notify Tag	NOTIFY TAG contains a single tag value, which is used to select entries in the Target Address table. Any entry in the Target Address table that contains a tag value equal to the value of an instance of this Trap Manager, is selected.
Notify Type	The type of notification of the SNMP Trap Settings can be configured as <i>Trap</i> or <i>Inform</i> .
Storage Type	STORAGE TYPE can be configured as <i>Volatile</i> or <i>Non-Volatile</i> .

## SNMP AgentX

Figure 7-35. SNMP AgentX Subagent Settings Page



Clicking the AGENTX link brings up the SNMP AGENTX SUBAGENT SETTINGS page (Figure 7-35), which allows you to configure SNMP AgentX sub-agent parameters. The parameters for this page are shown in Table 7-24.

Table 7-24. SNMP AgentX Subagent Settings Page Parameters

Parameter	Description
Transport Domain	This parameter allows you to specify the TCP.
IP Address Type	This parameter specifies <i>IPv4</i> or <i>IPv6</i> for the IP ADDRESS TYPE.

**Table 7-24. SNMP AgentX Subagent Settings Page Parameters (Continued)**

Parameter	Description
Master IP Address	This parameter specifies the Master Agent IP address.
Master Port No	This parameter specifies the Master Port number.

## RMON

The following pages can be used to set RMON (Remote Monitoring) features and settings:

- "RMON Basic Settings" on page 7-43
- "Event Configuration" on page 7-44
- "RMON Alarm Configuration" on page 7-45
- "Ethernet Statistics Configuration" on page 7-46
- "History Control Configuration" on page 7-47

### *RMON Basic Settings*

Figure 7-36. RMON Basic Settings Page

The screenshot shows the SUPERMICR web interface for a SWITCH SBM-GEM-X2C. The top navigation bar includes 'Refresh', 'Support', 'Help', 'About', and 'Log Out'. A status bar at the top right shows 'Speed' and 'Link' indicators for various ports (G1-12, EX1-EX2). The main navigation menu includes 'SMIS', 'Basic Settings', 'Events', 'Alarms', 'Ethernet Statistics', and 'History'. The 'Basic Settings' tab is active, displaying the 'RMON Basic Settings' page. The 'RMON Status' is currently set to 'Disabled', and there is an 'Apply' button below it. The left sidebar contains a tree view of system settings, including System Mgmt, File Management, Management Security, Syslog, ACL, Web Settings, SNMP, AGENT, AGENTX, RMON, QoS, NTP, Stack, Layer2 Mgmt, Layer3 Mgmt, Multicast, and Statistics.

Clicking the BASIC SETTINGS tab brings up the RMON BASIC SETTINGS page (Figure 7-36), which enables/disables the RMON feature using the RMON Status parameter.

## Event Configuration

Figure 7-37. Event Configuration Settings Page

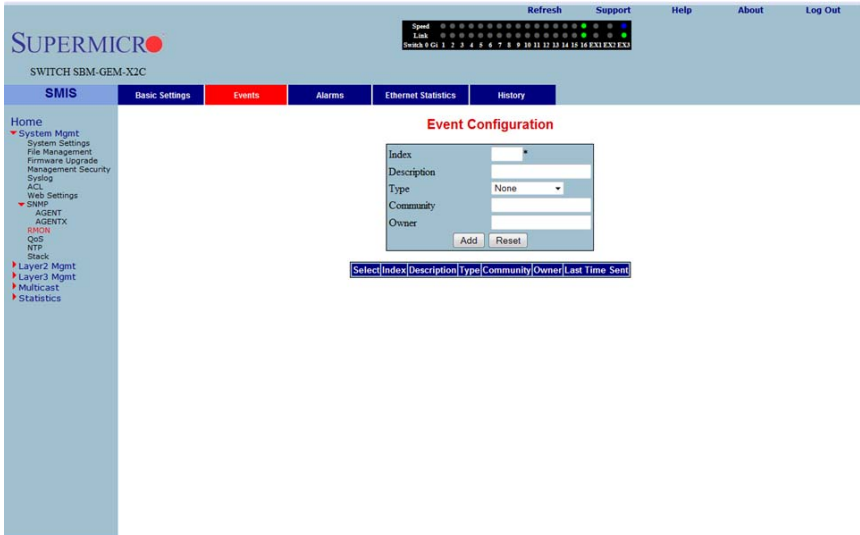

Clicking the EVENTS tab brings up the EVENT CONFIGURATIONS page (Figure 7-37), which configures RMON events. The parameters for this page are shown in Table 7-25.

Table 7-25. Event Configuration Page Parameters

Parameter	Description
Index	This parameter specifies the index to the Events table.
Description	This parameter specifies a brief description of the event.
Type	This parameter specifies the event configured. This can be a <i>Log</i> , an <i>SNMP Trap</i> , <i>Both</i> , or <i>None</i> . For the event type to display, <i>TRAP and Log</i> and <i>TRAP Community</i> must be configured.
Community	This parameter specifies the SNMP community string used for this trap. This is relevant when an SNMP trap is requested for an event. For event type to display, <i>TRAP and Log</i> and <i>TRAP Community</i> must be configured. Also make sure the configured community is active before adding an event on that community.
Owner	This parameter indicates the owner of this event.
Last Time Sent	This parameter denotes the time this event entry last generated an event.

## RMON Alarm Configuration

Figure 7-38. RMON Alarm Configuration Page

The screenshot shows the RMON Alarm Configuration page. The interface includes a top navigation bar with 'Refresh', 'Support', 'Help', 'About', and 'Log Out'. Below this is a 'SUPERMICR' logo and a status bar showing 'SWITCH SBM-GEM-X2C'. A main navigation menu has 'SMIS', 'Basic Settings', 'Events', 'Alarms', 'Ethernet Statistics', and 'History'. The 'Alarms' tab is active. The left sidebar lists various system management options, with 'RMON' expanded. The main configuration area is titled 'RMON Alarm Configuration' and contains a form with the following fields: Index, Interval, Variable, Sample type (set to 'Absolute value'), Rising Threshold, Falling Threshold, Rising Event Index, Falling Event Index, and Owner. 'Add' and 'Reset' buttons are at the bottom of the form. A status bar at the bottom of the form reads: 'Select[Index|Interval|Variable|Sample Type|Rising Threshold|Falling Threshold|Rising Event Index|Falling Event Index|Owner|Value]'.

Clicking the ALARM tab brings up the RMON ALARM CONFIGURATION page (Figure 7-38), which configures RMON Alarm parameters. The parameters for this page are shown in Table 7-26.

Table 7-26. RMON Alarm Configuration Page Parameters

Parameter	Description
Index	This parameter specifies the table index.
Interval	This parameter specifies the time interval for which the alarm monitors the variable.
Variable	This parameter specifies the MIB object on which the alarm is set.
Sample Type	You can set this parameter to an <i>Absolute Value</i> or as just an <i>Incremental Value</i> of the timer.
Rising Threshold	If the startup alarm is set as <i>Rising Alarm</i> and this threshold is reached, an alarm is raised.
Falling Threshold	If the startup alarm is set as <i>Falling Alarm</i> and this threshold is reached, an alarm is raised.
Rising Event Index	Indicates the index of the event to be raised when the RISING THRESHOLD is reached.

**Table 7-26. RMON Alarm Configuration Page Parameters (Continued)**

Parameter	Description
Falling Event Index	Indicates the index of the event to be raised when the FALLING THRESHOLD is reached.
Owner	Specifies the owner of the alarm.

### Ethernet Statistics Configuration

**Figure 7-39. Ethernet Statistics Configuration Page**

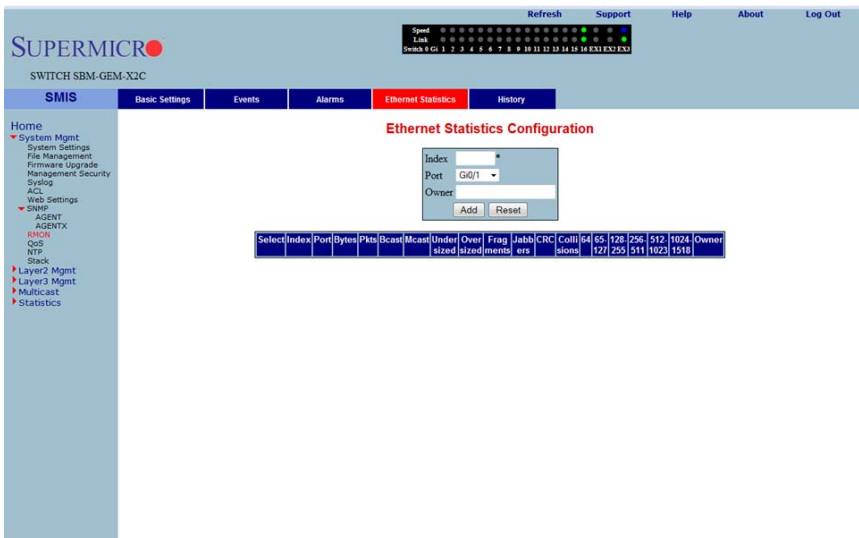

Clicking the ETHERNET STATISTICS tab brings up the ETHERNET STATISTICS CONFIGURATION page (Figure 7-39), which configures RMON Ethernet statistics parameters. The parameters for this page are shown in Table 7-27.

**Table 7-27. Ethernet Statistics Configuration Page Parameters**

Parameter	Description
Index	This parameter specifies the index to the table.
Port	This parameter specifies the Ethernet Port.
Octets	This parameter specifies the total number of octets received from the network.
Packets	This parameter specifies the total number of packets received from the network.
Broadcast Packets	This parameter specifies the total number of broadcast packets received from the network.

Table 7-27. Ethernet Statistics Configuration Page Parameters (Continued)

Parameter	Description
Multicast Packets	This parameter specifies the total number of multicast packets received from the network.
Owner	This parameter specifies the owner string.

## History Control Configuration

Figure 7-40. History Control Configuration Page

The screenshot shows the SUPERMICR SWITCH SBM-GEM-X2C web interface. The top navigation bar includes 'Refresh', 'Support', 'Help', 'About', and 'Log Out'. The left sidebar contains a menu with 'SMIS' selected, and sub-items like 'Home', 'System Mgmt', 'System Settings', 'File Management', 'Firmware Upgrade', 'Management Security', 'Syslog', 'ACL', 'Web Settings', 'SNMP', 'AGENT', 'AGENTX', 'RMON', 'QoS', 'NTP', 'Stack', 'Layer2 Mgmt', 'Layer3 Mgmt', 'Multicast', and 'Statistics'. The main content area is titled 'History Control Configuration' and contains a form with the following fields: Index (dropdown), Port (G0/1 dropdown), Buckets Requested (text input), Interval (text input), and Owner (text input). Below the form are 'Add' and 'Reset' buttons. At the bottom, there is a table header: Select | Index | Port | Buckets Requested | Buckets Granted | Interval | Owner.

Clicking the HISTORY tab brings up the HISTORY CONTROL CONFIGURATION page (Figure 7-40), which configures RMON history parameters. The parameters for this page are shown in Table 7-28.

Table 7-28. History Control Configuration Page Parameters

Parameter	Description
Index	This parameter specifies the index to the table.
Data Source	This parameter specifies the SNMP object ID of the variable for which the history is being collected.
Buckets Requested	Indicates the number of buckets to be configured for collecting the RMON statistics.
Interval	This parameter specifies the time interval between two successive polls to collect the statistics.
Owner	Denotes the owner of the RMON group of statistics.

**Table 7-28. History Control Configuration Page Parameters (Continued)**

Parameter	Description
Buckets Granted	Denotes the number of buckets granted for collecting the RMON statistics.
Status	This parameter specifies the status of the History Control entry as either <i>Valid</i> or <i>Invalid</i> .

## QoS

The QoS link of the System page opens the QoS Basic Settings page. This page allows you to configure QoS through following pages:

- "QOS Basic Settings" on page 7-48
- "QOS Classmap Settings" on page 7-49
- "QOS Polycmap Settings" on page 7-50
- "COSQ Scheduling Algorithm" on page 7-51
- "COSQ Weight and Bandwidth Configuration" on page 7-52

### QOS Basic Settings

**Figure 7-41. QOS Basic Settings Page**

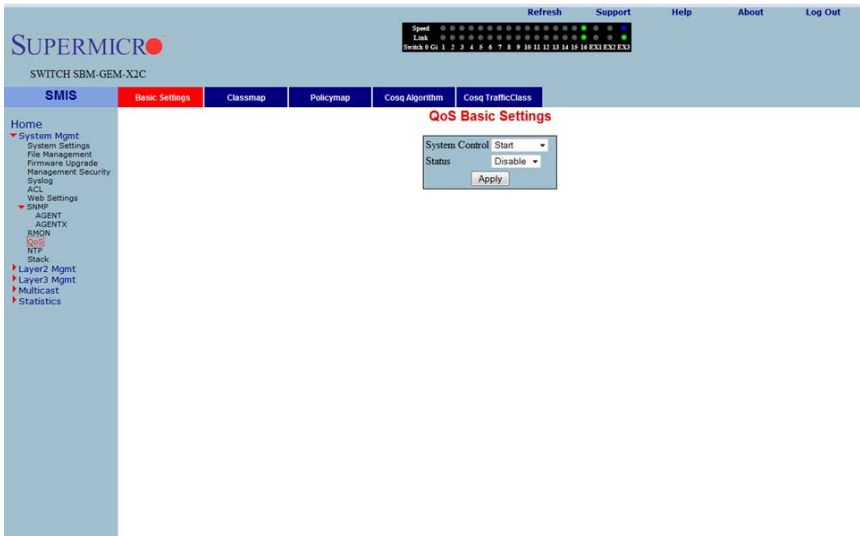

Clicking the BASIC SETTINGS tab brings up the QOS BASIC SETTINGS page (Figure 7-41), which allows you to configure QOS basic settings parameters. The parameters for this page are shown in Table 7-29.

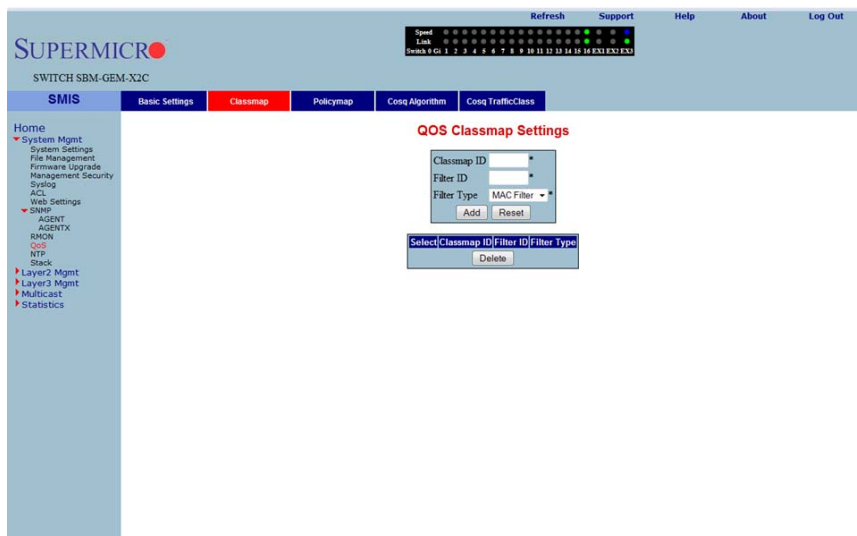

Table 7-29. QOS Basic Settings Page Parameters

Parameter	Description
System Control	With this parameter SYSTEM CONTROL can <i>Start</i> or <i>Shutdown</i> QoS.
Status	This parameter allows enabling/disabling of the QoS status.

## QOS Classmap Settings

Figure 7-42. QOS Classmap Settings Page



Clicking the CLASSMAP tab brings up the QOS CLASSMAP SETTINGS page (Figure 7-42), which is used to classify the stream of traffic. The parameters for this page are shown in Table 7-30.

Table 7-30. QOS Classmap Settings Page Parameters

Parameter	Description
Classmap ID	This parameter specifies a unique ID for the Classmap. It must be in the range from 1 to 65535.
Filter ID	This parameter specifies the unique filter ID associated with this Classmap.
Filter Type	This parameter specifies the filter type associated with the Classmap. It can be set as either <i>MAC filter (1)</i> or <i>IP filter (2)</i> .

## QOS Policymap Settings

Figure 7-43. QOS Policymap Settings Page

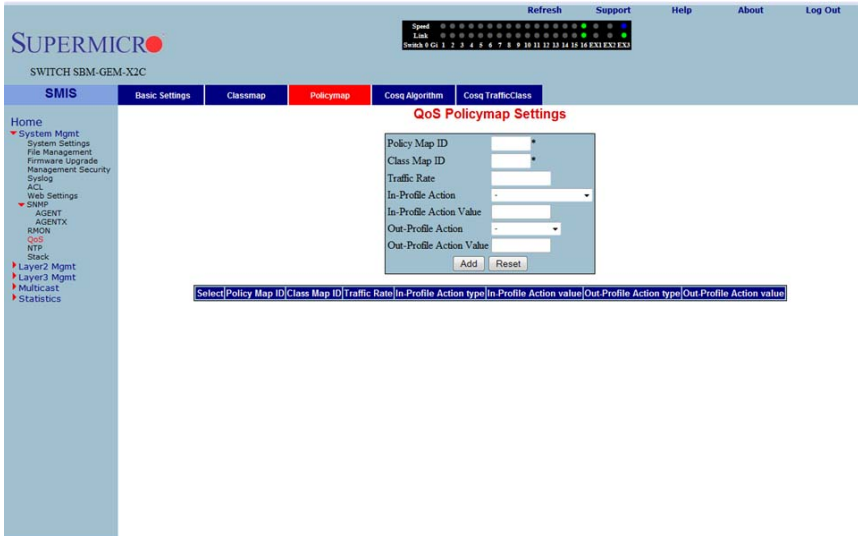

Clicking the POLICYMAP tab brings up the QOS POLICYMAP SETTINGS page (Figure 7-43), which is used to specify action for a specified classmap. The parameters for this page are shown in Table 7-31.

Table 7-31. QOS Policymap Settings Page Parameters

Parameter	Description
Policy Map ID	This parameter specifies the unique ID for Policymap. The value ranges between 1 and 65535.
Class Map ID	This parameter specifies the CLASS MAP ID to associate with Policymap.
Traffic Rate	This parameter specifies the TRAFFIC RATE of data that has to be applied.
In-Profile Action	This parameter specifies the action to be applied on matched data, and can be specified as either <i>Policy DSCP</i> or <i>Policy Precedence</i> .
Out-Profile Action	This parameter specifies the action to be applied on out-of-profile data, and can be specified as either <i>Policy DSCP</i> or <i>Drop</i> .
In-Profile Action Value	The IN-PROFILE ACTION VALUE can be specified from 0 to 7 for DSCP, or from 0 to 63 for IP Precedence.
Out-Profile Action Value	The OUT-PROFILE ACTION VALUE can be specified as <i>Drop</i> or from 0 to 63 for DSCP.

## COSQ Scheduling Algorithm

Figure 7-44. COSQ Scheduling Algorithm Settings Page

The screenshot shows the SUPERMICR web interface. At the top, there are navigation links: Refresh, Support, Help, About, and Log Out. Below that is a status bar with 'Speed Link' and a row of 16 colored indicators. The main navigation bar includes 'SMIS', 'Basic Settings', 'Classmap', 'Policymap', 'Cosq Algorithm' (highlighted), and 'Cosq TrafficClass'. The left sidebar contains a tree view with categories like System Mgmt, System Settings, File Management, Management Security, Status, ACL, Web Settings, SNMP, AGENT, AGENTX, RMON, QoS, NTP, Stack, Layer2 Mgmt, Layer3 Mgmt, Multicast, and Statistics. The main content area is titled 'COSQ Scheduling Algorithm Settings' with a sub-header 'G10.1 Ex0.3'. It features a table with two columns: 'Select' and 'Scheduling Algorithm'. The table lists 17 ports: G0/1 through G0/16, and Ex0/1 through Ex0/3. Each port has a radio button in the 'Select' column and a dropdown menu in the 'Scheduling Algorithm' column, all of which are currently set to 'Strict Priority'. An 'Apply' button is located at the bottom of the table.

Clicking the COSQ ALGORITHM tab brings up the COSQ SCHEDULING ALGORITHM SETTINGS page (Figure 7-44), which allows you to choose the COSQ (Class of Service Queue) scheduling algorithm for every port. The parameters for this page are shown in Table 7-32.

Table 7-32. COSQ Scheduling Algorithm Settings Page Parameters

Parameter	Description
Port Number	This list of ports allows you to select from the port index for your selected algorithm.
Scheduling Algorithm	The SCHEDULING ALGORITHM can be selected as one of the following: <ul style="list-style-type: none"> <li>Strict Priority</li> <li>Round Robin</li> <li>Weighted Round Robin</li> <li>Weighted Fair Queuein</li> <li>Strict Round Robin</li> <li>Strict Weighted Round Robin</li> <li>Strict Weighted Fair Queueing</li> <li>Deficit Round Robin</li> </ul>

## COSQ Weight and Bandwidth Configuration

Figure 7-45. COSQ Weight and Bandwidth Configurations Page

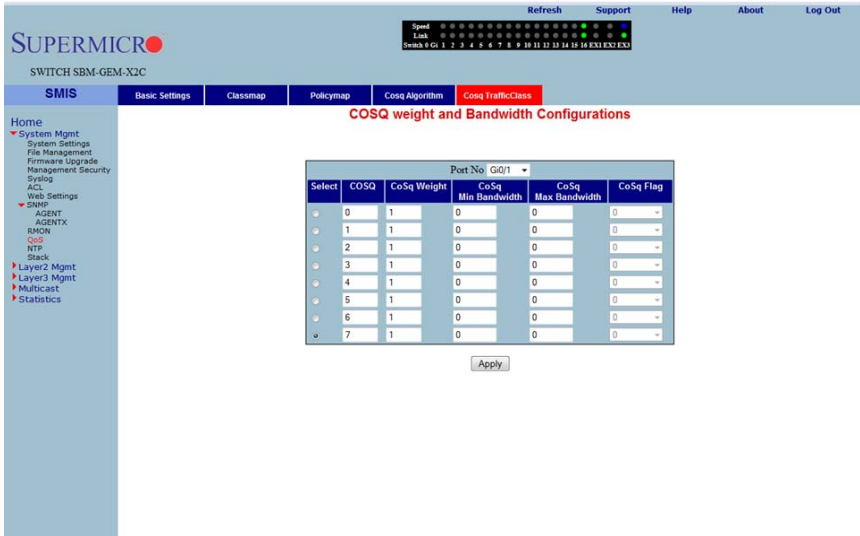

Clicking the COSQ TRAFFIC CLASS tab brings up the COSQ WEIGHT AND BANDWIDTH CONFIGURATIONS page (Figure 7-45), which allows you to configure the weight and bandwidth for CoS Queues. The parameters for this page are shown in Table 7-33.

Table 7-33. COSQ Weight and Bandwidth Configurations Page Parameters

Parameter	Description
COSQ Queue	This parameter allows you to select between 0 to 7 for your COSQ QUEUE value.
COSQ Weight	This parameter allows you to select between 0 to 15 for your COSQ WEIGHT value.
COSQ Min Bandwidth	This parameter configures minimum bandwidth between 1 and 262143.
COSQ Max Bandwidth	This parameter configures maximum bandwidth between 1 and 262143.
COSQ Flag	Use this parameter to set a flag for this queue.

## NTP Settings

Figure 7-46. NTP Settings Page

The screenshot shows the NTP Settings page with the following configuration:

- NTP Client:**
  - Ntp Status: DISABLED
  - Receive Server Update: BROADCAST
- Timezone Settings:**
  - Hour Offset: 0
  - Minutes Offset: 0
- NTP Servers:**
  - Server IP Address: (empty)
  - Key: (dropdown)
  - Interval: (dropdown)
  - Preferred: (dropdown)
- NTP Server Keys:**
  - Key Id: (input)
  - Key String: (input)

Clicking the NTP link brings up the NTP SETTINGS page (Figure 7-46), which configures the Network Time Protocol (NTP). The parameters for this page are shown in Table 7-34.

Table 7-34. NTP Settings Page Parameters

Parameter	Description
<b>NTP Client Settings</b>	
NTP Status	This field enables or disables NTP in the switch. Configure the NTP SERVERS section to enable NTP.
Receive Server Update	The value for this parameter could be <i>Broadcast</i> or <i>Unicast</i> . To process the broadcast NTP updates from the server, choose the <i>Broadcast</i> option.
<b>Timezone Settings</b>	
Hour Offset	This parameter allows you to enter an hour offset from GMT for local time.
Minutes Offset	This parameter allows you to enter a minutes offset (after hour offset) from GMT for local time.
<b>NTP Servers</b>	
Server IP Address	Use this parameter to enter the NTP server IP address.
Key	Choose the key from the configured list. These keys are configurable in this page in the NTP SERVER KEYS section's fields.

**Table 7-34. NTP Settings Page Parameters (Continued)**

Parameter	Description
Interval	This parameter allows you to choose the interval from the given list.
Preferred	This parameter allows you to choose the preferred server. Choose Yes if this server needs to be preferred over other configured NTP servers. You can add multiple NTP servers.
<b>NTP Servers Keys</b>	
Key ID	Use this parameter to select a number to identify the configured key strings.
Key String	Use this parameter to specify any string to be used as a key to handshake with NTP servers.

## Stack

The Supermicro Intelligent switch supports stacking of Supermicro switch units. Switch stacking is created by connecting switches in a daisy chain. One of the stacked switches is selected as a Master based on its configurations. The Master switch provides management support for the whole stack. Other switches in the stack are referred to as slave switches.



**NOTE:** Make sure all stacked switches are running the same version of firmware.

The Master switch manages the control plane traffic for all stacked switches. When the current master switch fails, the backup master is then selected as the current master. The Master selection algorithm is based on a priority configuration. If two switches have the same priority, the switch with the lowest MAC address is selected as the Master switch.

## CX4 Cable Length

Stacking is supported with CX-4 cables only. The CX-4 cable used for stacking should be no more than 3-meters in length, because stacking internally runs at 12-Gbps and therefore requires a more robust signal than longer cable lengths might provide reliably. The industry standard stacking cable length is 3-meters.



**NOTE:** For stacking ports, you do not need to configure CX4 cable length. It is fixed as "short" for stacking ports.

When used for 10G Ethernet uplinks, the CX-4 ports can be from 1-meter to 12-meters in length; the maximum CX-4 cable length supported on Supermicro switches is 12-meters.

It is acceptable to use a 1-meter stacking cable for port 1 and a 12-meter uplink cable for port 2. You will only need to configure the long cable preference for port 2. Do this by selecting the Port Number in the CX4 CABLE LENGTH screen (Figure 7-47) and then selecting the "long" option.

Figure 7-47. Configuring CX4 Cable Length

The screenshot shows the SMIS (Supermicro Management Interface) web page for a SWITCH SSE-G48-TG4. The main content area is titled "CX4 Cable Length Settings". It features a table with the following structure:

ALL	Port	CX4 Cable Length Option
<input type="checkbox"/>	Exp01	Short - Default
<input type="checkbox"/>	Exp02	Short - Default
<input type="checkbox"/>	Exp03	Short - Default
<input type="checkbox"/>	Exp04	Short - Default

Below the table is an "Apply" button. A note states: "Note: For cables of 1M to 7M length, use default short option. For cables longer than 7M and up to 12M, use long option."

This configuration is done on an individual port basis. Thus, you can use "short" for one port and "long" for the other port. Alternatively you might use both "short" or, if neither are for stacking, both can be "long" cables.

## Enabling Stacking

By default, Supermicro switches act as stand-alone switches. This stand-alone default facilitates using 10G Ethernet ports as Extreme Ethernet ports for uplinks.

When stacking is enabled the stacking ports are dedicated for stacking purposes. Stacking can be enabled using the command `stack` with the switch identifier and priority. The detailed command syntax is explained below.



**NOTE:** When stacking is enabled, the switch needs to be rebooted to make it effective.



**NOTE:** When a switch is acting as a stand-alone switch with stacking disabled, all physical interfaces are numbered as 0/1 to 0/n.

When the switch is in stacking mode, the interfaces are numbered as <switch id>/1 to <switch id> / n.

In non-stacking mode, the switch ID is considered to be 0.

In the stacking mode, any firmware upgrade in the Master Switch will automatically initiate a firmware upgrade to all attached stack member switches. Firmware upgrade confirmation from stack member switches will be displayed in the Master Switch management interface.

Also in the stacking mode, the user can reload all stacked switches or any selected stack member switch from the master management interface.

The interface numbers change between stacking and non-stacking cases due to the switch ID. So configurations saved for stacking are not valid for non-stacking cases and vice versa.



**NOTE:** If you choose stacking using the `stack` command from a non-stacking case, and the configurations are already saved for restoring the switch, it will rename the configuration file by adding a suffix `_nonstack` and will not restore this file when the switch reboots with stacking enabled.

Similarly, if you choose non-stacking using the `no stack` command from the stacking case, and the configurations are already saved for restoring the switch, it will rename the configuration file by adding a suffix `_stack` and will not restore this file when the switch reboots with stacking disabled.

## Adding Stacking Members

Connect the stacked switches using stacking cables. For better redundancy, connect the switches daisy-chained as shown in [Figure 7-48](#). This chain connectivity helps to maintain stacking in case a single link or switch fails.

Before connecting switches in stacking, make sure stacking is enabled in all switches and that the switch identifier and priorities are all configured properly.



There is no other specific configuration required to add stacked switches. If two stacking-enabled switches connect through stacking cables, they form a stack.



**NOTE:** Do not use the same switch ID for multiple switches on the stack.

**Figure 7-48. Switch Diagram**

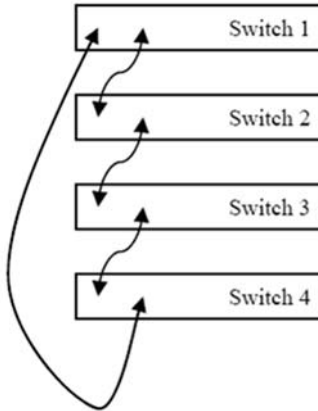

The SBM-GEM-X2C+ has four LEDs to display the stacking identifier. Due to the limited space available for LEDs, the stacking identifier is displayed in binary form using these four stacking LEDs.

Stacking Identifier	Stacking ID LED 4	Stacking ID LED 3	Stacking ID LED 2	Stacking ID LED 1
1	OFF	OFF	OFF	ON
2	OFF	OFF	ON	OFF
3	OFF	OFF	ON	ON
4	OFF	ON	OFF	OFF
5	OFF	ON	OFF	ON
6	OFF	ON	ON	OFF
7	OFF	ON	ON	ON
8	ON	OFF	OFF	OFF
9	ON	OFF	OFF	ON
10	ON	OFF	ON	OFF
11	ON	OFF	ON	ON
12	ON	ON	OFF	OFF
13	ON	ON	OFF	ON
14	ON	ON	ON	OFF
15	ON	ON	ON	ON
16	OFF	OFF	OFF	OFF



**NOTE:** In a stack only one switch can be configured as master. The slave switches will not allow you to configure anything except *stacking disabled*. To login to slave switches, use a login name as **"stackuser"** and password as **"stack123"**.

### Removing a stacked switch

To remove a switch from stacking follow the below recommended procedure.

1. Disconnect stacking cables.
2. Reboot the removed switch as a standalone switch.
3. *Disable* stacking. Execute the "no stack" command.
4. Reboot the switch again to operate as regular stand-alone switch.



**NOTE:** When a switch is moved from stacking to stand-alone mode, the saved stacking configurations can not be loaded in stand-alone mode. When stacking is disabled, the switch software renames the existing configuration file to avoid automatic restoration of stacking configurations on a stand-alone switch.

The following pages are available for configuring Stack settings;

- "Stack Configuration" on page 7-59
- "Stack Details" on page 7-60
- "Stack Counters" on page 7-62

## Stack Configuration

Figure 7-49. Stack Configuration Page

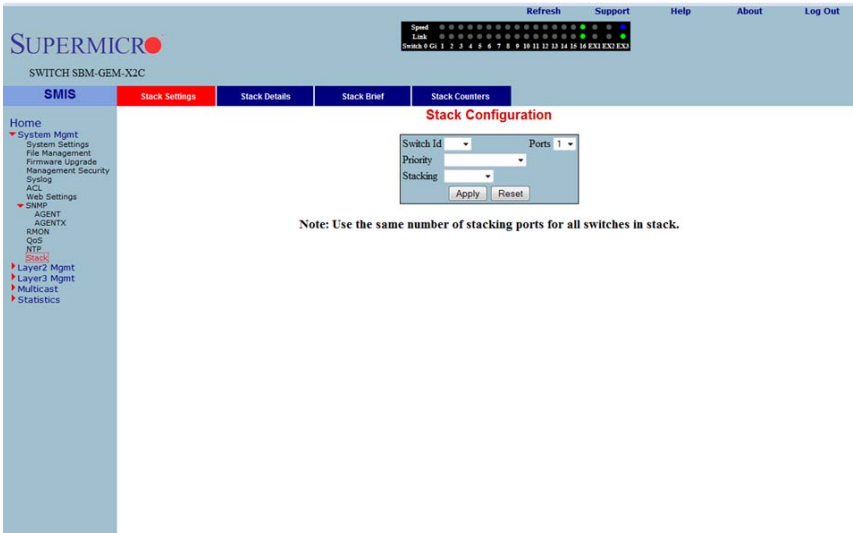

The screenshot shows the SUPERMICR web interface for a SWITCH SBM-GEM-X2C. The top navigation bar includes 'Refresh', 'Support', 'Help', 'About', and 'Log Out'. The left sidebar contains a menu with 'Stack Settings' highlighted. The main content area is titled 'Stack Configuration' and contains a form with the following fields:

- Switch Id: [Dropdown menu]
- Ports: [Dropdown menu]
- Priority: [Dropdown menu]
- Stacking: [Dropdown menu]
- Buttons: Apply, Reset

Below the form, a note reads: "Note: Use the same number of stacking ports for all switches in stack."

Clicking the STACK SETTINGS tab brings up the STACK CONFIGURATION page (Figure 7-49), which configures the stacking feature. The parameters for this page are shown in Table 7-35.

Table 7-35. Stack Configuration Page Parameters

Parameter	Description
Switch ID	<p>This parameter defines a switch identifier number for this switch. This identifier should be unique in the stack, since the number is used in referring all physical interfaces available in this switch.</p> <p>So for example, if this parameter is chosen as 2, the physical interfaces will be referred as <i>Gi2/1</i>, <i>Gi2/1</i> and so on.</p> <p>For non-stacking, stand-alone cases this switch ID is considered as zero.</p>
Ports	<p>This parameter represents the number of stacking ports. You can choose the number based upon your preferred stacking configuration and available CX4 ports. It is recommended that you use two CX4 ports as stacking ports to get redundancy.</p>

**Table 7-35. Stack Configuration Page Parameters (Continued)**

Parameter	Description
Priority	This parameter chooses the priority for this switch in the Stacking Master selection. It could be configured as <i>Preferred Master</i> , <i>Backup Master</i> or <i>Preferred Slave</i> .
Stacking	This parameter enables or disables stacking. <b>NOTE:</b> Any change in stacking status requires a reboot of the switch.

**Stack Details**

**Figure 7-50. Stack Details Page**

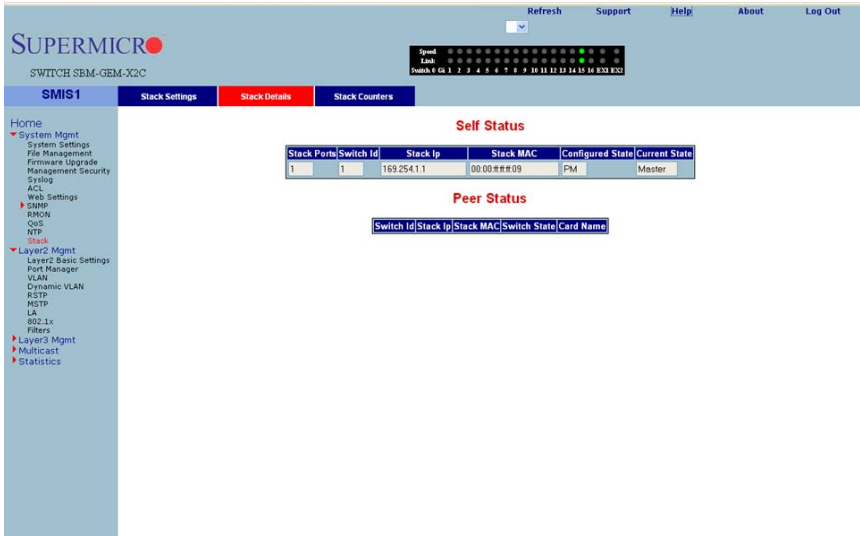

Clicking the STACK DETAILS tab brings up the STACK DETAILS page (Figure 7-50), which displays stacking details. The parameters for this page are shown in Table 7-36.

**Table 7-36. Stack Details Page Parameters**

Parameter	Description
<b>Self Status</b>	
Stack Ports	This is the number of stacking ports configured in this switch.
Switch ID	This parameter is used to specify the switch identifier of this switch.
Stack IP	This parameter is used to specify the IP address of this switch. This IP address is used to communicate between stack member switches.
Stack MAC	This parameter is used to specify the MAC address of this switch. This MAC address is used to communicate between stack member switches.

Table 7-36. Stack Details Page Parameters (Continued)

Parameter	Description
Configured State	This parameter is used to specify the priority of this switch.
Current State	This parameter is used to specify the current status of this switch as <i>Master</i> or <i>Slave</i> .
<b>Peer Status</b> – The following parameters display information about all connected stack Slave switches.	
Switch ID	This parameter is used to specify the switch identifier of the Slave switch.
Stack IP	This parameter is used to specify the IP address of the Slave switch. This IP address is used to communicate between stack member switches.
Stack MAC	This parameter is used to specify the MAC address of the Slave switch. This MAC address is used to communicate between stack member switches.
Switch State	This parameter is used to specify the current status of the Slave switch.
Card Name	This parameter is used to specify the type of Slave switch.

### Stack Link Status

Figure 7-51. Stack Link Status Page



The STACK LINK STATUS page (Figure 7-51) displays the stack interface link status as “up” or “down”.

## Stack Counters

Figure 7-52. Stack Counter Details Page

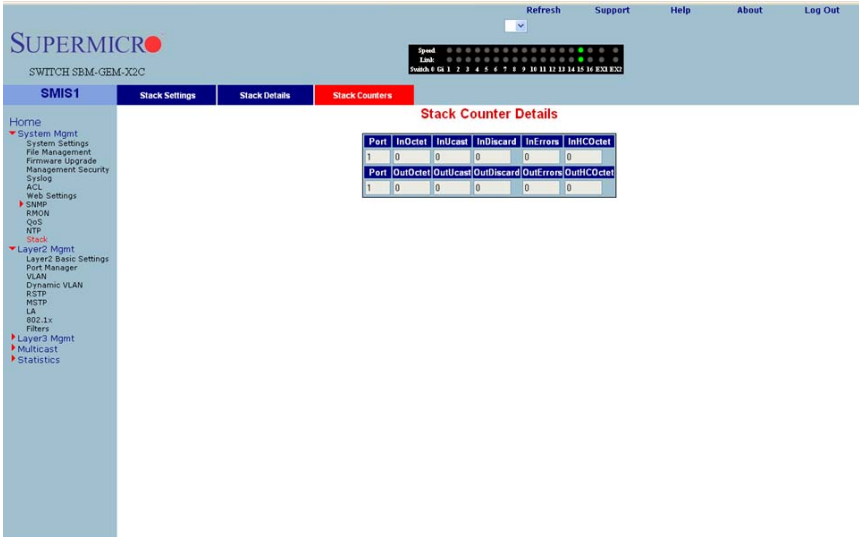

Clicking the STACK COUNTERS tab brings up the STACK COUNTERS DETAILS page (Figure 7-52), which displays statistics for stacking ports. The parameters for this page are shown in Table 7-37.

Table 7-37. Stack Counter Details Page Parameters

Parameter	Description
Port	This parameter displays the stacking port identifier.
<b>Received Statistics</b>	
InOctet	This parameter displays the number of bytes received.
InUcast	This parameter displays the number of unicast packets received.
InDiscard	This parameter displays the number of received packets which were discarded.
InErrors	This parameter displays the number of packets received with errors.
InHCOctet	This parameter displays the number of bytes received with HC.
<b>Transmit Statistics</b>	
OutOctet	This parameter displays the number of bytes transmitted.
OutUcast	This parameter displays the number of unicast packets transmitted.
OutDiscard	This parameter displays the number of packets discarded in transmission.

Table 7-37. Stack Counter Details Page Parameters (Continued)

Parameter	Description
OutErrors	This parameter displays the number of packets transmitted got errors.
OutHCOctet	This parameter displays the number of bytes transmitted with HC.



**NOTE:** HC refers to the *High Capacity* value of the counter used. The regular counter is 32-bit. The HC counter is 64-bit.

## Reload

Figure 7-53. System Settings Page – Reload

The screenshot shows the SUPERMICRO web interface for a switch (SWITCH1 LED STATUS). The main content area is titled "System Settings" and contains the following configuration fields:

- Device Name: SMS
- Switch Base MAC Address: 00:30:48:e0:21:4c
- IP Address Mode: Manual
- Default IP Address: 192.168.2.3
- Subnet Mask: 255.255.255.0
- SNMP EngineID: 80.00.08.1c:04.46.53 \*
- Device Contact: http://www.supermicro.com
- Device Location: Supermicro
- PIM Mode: Sparse
- Snoop Forward Mode: MAC Based \*
- Configuration Restore Status: Not Initiated
- Device Up Time: 0 days 0 hrs 37 mins 27 secs
- Http Server Status: Enable
- Http Port Number: 80

Buttons include "Apply", "Reload Switch", and "Reset To Factory Defaults \*". A warning message states: "\* Restart of switch required, if these values are changed." The interface also features a navigation menu on the left and a top status bar with "Refresh", "Support", "Help", "About", and "Log Out" buttons.

A "Switch Reload" function (Figure 7-53) is available in the SYSTEM SETTINGS page in the SYSTEM MANAGEMENT section.

You can use the SWITCH select option to choose the switch to reload, or you can select the ALL SWITCHES option to reload all stack member switches.

The FORCE check box provides an option to force a reload of the switch when the Master Switch is waiting for confirmation messages from slave switches for stacking configurations.

Click the RELOAD SWITCH button to reload the selected switch

## 7-5 Layer 2 Management

The LAYER2 MANAGEMENT page (Figure 7-54) has links to all pages with Layer2 controls.

Figure 7-54. Layer2 Management Page

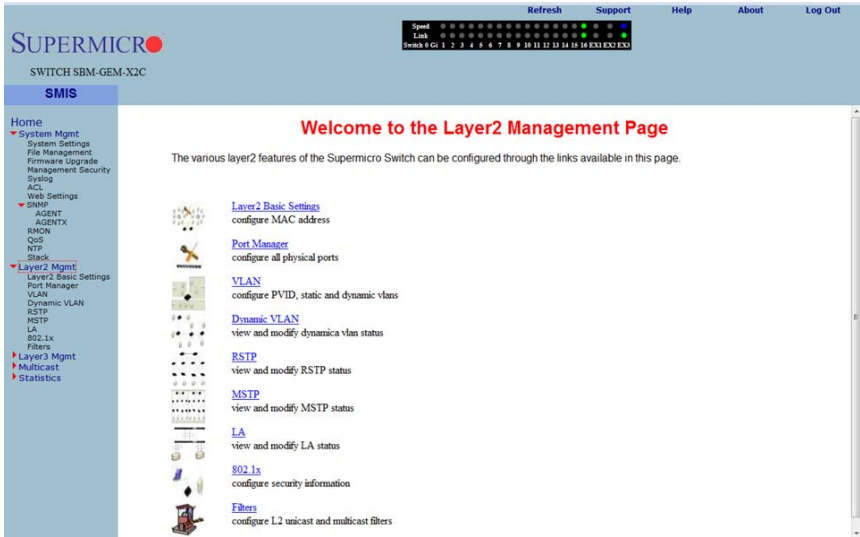



## Layer 2 Basic Settings

Figure 7-55. MAC Address Table Settings Page



Clicking the LAYER2 BASIC SETTINGS link brings up the MAC ADDRESS TABLE SETTINGS page (Figure 7-55), which gives you the option to change MAC aging time. MAC address confirmation can be done with this time interval.

## Port Manager

The PORT MANAGER link has links to the following web pages:

- "Port Basic Settings" on page 7-66
- "Port Monitoring" on page 7-68
- "VLAN Traffic Class" on page 7-69
- "Port Control" on page 7-70
- "Rate Limiting" on page 7-71



**NOTE:** In all port based configuration pages, the port number group links are provided on the top.

In the normal standalone operation of the switch, there is only one link and the corresponding port configuration is displayed below it.

In case of stacking, multiple groups of port links are displayed. These links provide the configuration of ports from different stack member switches. To view the configuration of ports from a particular stack member switch, select the corresponding port links. For example, if three switches having switch identifier as 1, 2, and 3 are stacked together, the links will be as follows.

Gi1/1-Ex1/2 | Gi2/1-Ex2/2 | Gi3/1-Ex3/2

So to view the ports of switch 2, you need to select the Gi2/1-Ex2/2 link.

### Port Basic Settings

Figure 7-56. Port Basic Settings Page

The screenshot shows the 'Port Basic Settings' page for switch SBM-GEM-X2C. The interface includes a navigation menu on the left with options like Home, System Mgmt, and Layer2 Mgmt. The main content area displays a table of port configurations for the selected switch group 'Gi0/1-Ex0/3'. The table has columns for Port, Link Status, Admin State, Default User Priority, Switch Port, Switch Port Mode, MTU, and Link Up/Down Tcp. All ports listed are in an 'Up' state with an 'Admin State' of '0' and a 'Switch Port Mode' of 'Hybrid'. The MTU for all ports is 1500. The link status is 'Enabled' for all ports.

Clear All	Port	Link Status	Admin State	Default User Priority	Switch Port	Switch Port Mode	MTU	Link Up/Down Tcp
Select All								
<input type="checkbox"/>	Gi0/1	Up	0	Yes	Hybrid	1500	Enabled	▼
<input type="checkbox"/>	Gi0/2	Up	0	Yes	Hybrid	1500	Enabled	▼
<input type="checkbox"/>	Gi0/3	Up	0	Yes	Hybrid	1500	Enabled	▼
<input type="checkbox"/>	Gi0/4	Up	0	Yes	Hybrid	1500	Enabled	▼
<input type="checkbox"/>	Gi0/5	Up	0	Yes	Hybrid	1500	Enabled	▼
<input type="checkbox"/>	Gi0/6	Up	0	Yes	Hybrid	1500	Enabled	▼
<input type="checkbox"/>	Gi0/7	Up	0	Yes	Hybrid	1500	Enabled	▼
<input type="checkbox"/>	Gi0/8	Up	0	Yes	Hybrid	1500	Enabled	▼
<input type="checkbox"/>	Gi0/9	Up	0	Yes	Hybrid	1500	Enabled	▼
<input type="checkbox"/>	Gi0/10	Up	0	Yes	Hybrid	1500	Enabled	▼
<input type="checkbox"/>	Gi0/11	Up	0	Yes	Hybrid	1500	Enabled	▼
<input type="checkbox"/>	Gi0/12	Up	0	Yes	Hybrid	1500	Enabled	▼
<input type="checkbox"/>	Gi0/13	Up	0	Yes	Hybrid	1500	Enabled	▼
<input type="checkbox"/>	Gi0/14	Up	0	Yes	Hybrid	1500	Enabled	▼
<input type="checkbox"/>	Gi0/15	Up	0	Yes	Hybrid	1500	Enabled	▼
<input type="checkbox"/>	Gi0/16	Up	0	Yes	Hybrid	1500	Enabled	▼
<input type="checkbox"/>	Ex0/1	Up	0	Yes	Hybrid	16338	Enabled	▼
<input type="checkbox"/>	Ex0/2	Up	0	Yes	Hybrid	16338	Enabled	▼
<input type="checkbox"/>	Ex0/3	Up	0	Yes	Hybrid	16338	Enabled	▼

Clicking the BASIC SETTINGS tab brings up the PORT BASIC SETTINGS page (Figure 7-56), which allows you to configure port status and mode information. This page also helps configuring priority and MTU. The parameters for this page are shown in Table 7-38.

**Table 7-38. Port Basic Settings Page Parameters**

Parameter	Description
Port	This displays the port number.
Link status	This column shows the physical link status as an UP or Down arrow. A green up arrow indicates that the status of the port is up, while the red down arrow indicates that the status of the port is down.
Admin State	This parameter allows you to administratively configure the admin state as <i>Up</i> or <i>Down</i> .
Default User Priority	This parameter allows you to set the priority from 0 to 7.
Switch Port	By default all ports are switch ports for layer 2 switching. To configure a port as a layer 3 routed port, choose <i>No</i> .
Switch Port Mode	Use this control allows to set the access mode as either <i>Trunk</i> or <i>Hybrid</i> .
MTU	This sets the MTU value. The Minimum is 90 and Maximum is 16338. A port must be administratively down in order to change the MTU. Jumbo frames of up to 9216 bytes are supported on 1G links. Jumbo frames of up to 16338 bytes are supported on 10G links.
Link Up/Down Trap	This parameter enables or disables SNMP trap generation for port up and down events.

## Port Monitoring

Figure 7-57. Port Monitoring Page

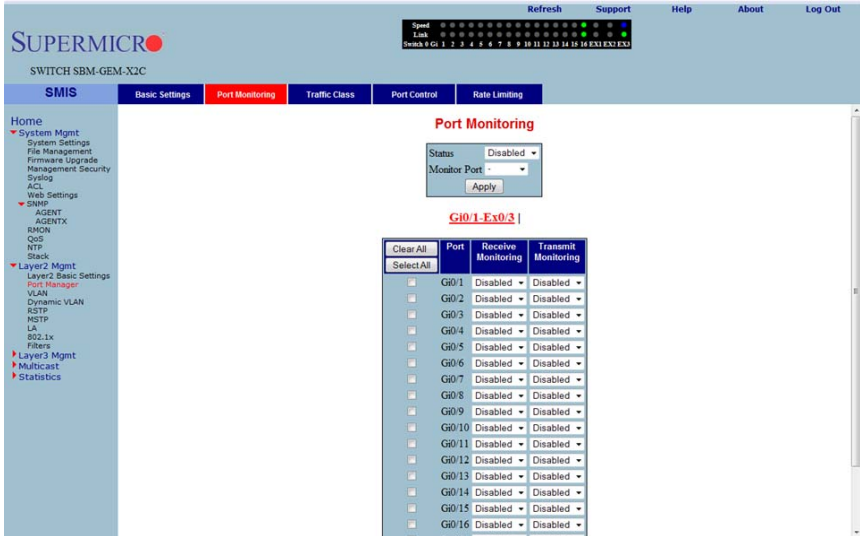

Clicking the PORT MONITORING tab brings up the PORT MONITORING page (Figure 7-57), which allows you to enable or disable monitoring on port interface. The parameters for this page are shown in Table 7-39.

Table 7-39. Port Monitoring Page Parameters

Parameter	Description
Status	This parameter enables or disables the port monitoring.
Port	This displays the port number.
Receive Monitoring	This parameter enables or disables the receive monitoring.
Transmit Monitoring	This parameter enables or disables the transmit monitoring.

## VLAN Traffic Class

Figure 7-58. VLAN Traffic Class Mapping Page

The screenshot shows the SUPERMICR SWITCH SBM-GEM.X2C web interface. The top navigation bar includes 'SMIS', 'Basic Settings', 'Port Monitoring', 'Traffic Class' (selected), 'Port Control', and 'Rate Limiting'. The main content area is titled 'VLAN Traffic Class Mapping' and 'G10-1-Ex0-3'. A table with 10 columns (Port, Priority 0-7) and 17 rows (G10/1 to Ex0/3) is displayed. Each cell contains a dropdown menu. An 'Apply' button is at the bottom of the table.

Clear All Select All	Port	Priority 0	Priority 1	Priority 2	Priority 3	Priority 4	Priority 5	Priority 6	Priority 7
<input type="checkbox"/>	G10/1	0	0	1	1	2	2	3	3
<input type="checkbox"/>	G10/2	0	0	1	1	2	2	3	3
<input type="checkbox"/>	G10/3	0	0	1	1	2	2	3	3
<input type="checkbox"/>	G10/4	0	0	1	1	2	2	3	3
<input type="checkbox"/>	G10/5	0	0	1	1	2	2	3	3
<input type="checkbox"/>	G10/6	0	0	1	1	2	2	3	3
<input type="checkbox"/>	G10/7	0	0	1	1	2	2	3	3
<input type="checkbox"/>	G10/8	0	0	1	1	2	2	3	3
<input type="checkbox"/>	G10/9	0	0	1	1	2	2	3	3
<input type="checkbox"/>	G10/10	0	0	1	1	2	2	3	3
<input type="checkbox"/>	G10/11	0	0	1	1	2	2	3	3
<input type="checkbox"/>	G10/12	0	0	1	1	2	2	3	3
<input type="checkbox"/>	G10/13	0	0	1	1	2	2	3	3
<input type="checkbox"/>	G10/14	0	0	1	1	2	2	3	3
<input type="checkbox"/>	G10/15	0	0	1	1	2	2	3	3
<input type="checkbox"/>	G10/16	0	0	1	1	2	2	3	3
<input type="checkbox"/>	Ex0/1	0	0	1	1	2	2	3	3
<input type="checkbox"/>	Ex0/2	0	0	1	1	2	2	3	3
<input type="checkbox"/>	Ex0/3	0	0	1	1	2	2	3	3

Clicking the TRAFFIC CLASS tab brings up the VLAN TRAFFIC CLASS MAPPING page (Figure 7-58), which allows you to map a priority to a traffic class. The parameters for this page are shown in Table 7-40.

Table 7-40. VLAN Traffic Class Mapping Page Parameters

Parameter	Description
Port	This displays the port number.
Priority 0	This parameter chooses any traffic class 0 to 7 to map with priority 0.
Priority 1	This parameter chooses any traffic class 0 to 7 to map with priority 1.
Priority 2	This parameter chooses any traffic class 0 to 7 to map with priority 2.
Priority 3	This parameter chooses any traffic class 0 to 7 to map with priority 3.
Priority 4	This parameter chooses any traffic class 0 to 7 to map with priority 4.
Priority 5	This parameter chooses any traffic class 0 to 7 to map with priority 5.
Priority 6	This parameter chooses any traffic class 0 to 7 to map with priority 6.
Priority 7	This parameter chooses any traffic class 0 to 7 to map with priority 7.

Port Control

Figure 7-59. Port Control Page

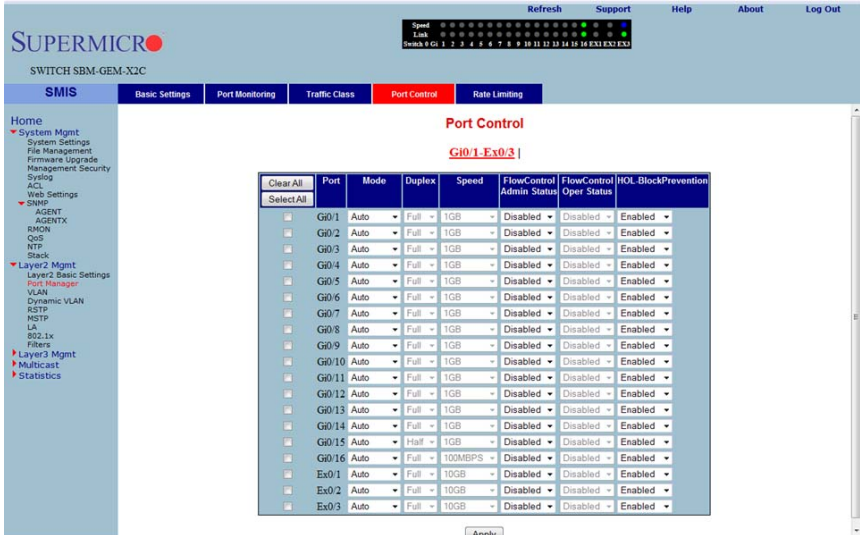

Clicking the PORT CONTROL tab brings up the PORT CONTROL page (Figure 7-59), which allows you to configure specific parameters of the port. You can choose between *Auto-negotiation* and *No-negotiation* for a port. If *No-negotiation* is chosen, then the speed of the link, FlowControl and duplex modes can be configured. The parameters for this page are shown in Table 7-41.

Table 7-41. Port Control Page Parameters

Parameter	Description
Port	This displays the port number.
Mode	This parameter allows you to select either <i>Auto Negotiation</i> or <i>No-negotiation</i> .
Duplex	This parameter allows you to select either <i>Full Duplex</i> or <i>Half Duplex</i> .
Speed	This parameter allows you to select the speed as <i>10 Mbps</i> , <i>100 Mbps</i> or <i>1 Gbps</i> .
Flow Control Admin Status	This parameter allows you to specify the Flow Control Admin Status as either <i>Disabled</i> , <i>Transmit Flow Control Enabled</i> , <i>Receive Flow Control Enabled</i> or both <i>Transmit and Receive Flow Control Enabled</i> .
Flow Control Operation Status	This parameter displays the status of the flow control.
HOL Block Prevention	This parameter allows you to enable or disable Head of Line block prevention.

## Rate Limiting

Figure 7-60. Rate Limiting Page

The screenshot shows the 'Rate Limiting' configuration page for a SUPERMICR switch. The page title is 'Rate Limiting' and the selected port is 'G0/1-Ex0/1'. Below the title is a table with the following structure:

Clear All	Select All	Port	Ingress Rate Limit			Egress Rate Limit	
			DLF Level	Broadcast Level	Multicast Level	Egress Port Rate Limit	Port Burst Size
<input type="checkbox"/>		G0/1	0	0	0	0	0
<input type="checkbox"/>		G0/2	0	0	0	0	0
<input type="checkbox"/>		G0/3	0	0	0	0	0
<input type="checkbox"/>		G0/4	0	0	0	0	0
<input type="checkbox"/>		G0/5	0	0	0	0	0
<input type="checkbox"/>		G0/6	0	0	0	0	0
<input type="checkbox"/>		G0/7	0	0	0	0	0
<input type="checkbox"/>		G0/8	0	0	0	0	0
<input type="checkbox"/>		G0/9	0	0	0	0	0
<input type="checkbox"/>		G0/10	0	0	0	0	0
<input type="checkbox"/>		G0/11	0	0	0	0	0
<input type="checkbox"/>		G0/12	0	0	0	0	0
<input type="checkbox"/>		G0/13	0	0	0	0	0
<input type="checkbox"/>		G0/14	0	0	0	0	0
<input type="checkbox"/>		G0/15	0	0	0	0	0
<input type="checkbox"/>		G0/16	0	0	0	0	0
<input type="checkbox"/>		Ex0/1	0	0	0	0	0

Clicking the RATE LIMITING tab brings up the RATE LIMITING page (Figure 7-60), which allows you to configure rate limiting for the port interface. The parameters for this page are shown in Table 7-42.

Table 7-42. Rate Limiting Page Parameters

Parameter	Description
Port	This displays the port number.
The following parameters are configurable for Ingress Rate Limiting.	
DLF Level	This parameter allows you to specify the destination lookup failure packets per second.
Broadcast Level	This parameter allows you to specify the broadcast packets per second.
Multicast Level	This parameter allows you to specify the multicast packets per second.
The following parameters are configurable for Egress Rate Limiting.	
Egress Port Rate Limit	This parameter allows you to specify the egress limit of packets per second.
Egress Port Burst Size	This parameter allows you to specify the egress limit of packet burst size.

## VLAN

The VLAN link allows to configure the VLAN information. VLAN configuration information has been provided in the following pages:

- "VLAN Basic Settings" on page 7-72
- "Port Settings" on page 7-73
- "Static VLAN" on page 7-74
- "Protocol Group" on page 7-75
- "Port Protocol" on page 7-75
- "Vlan Port MAC Map" on page 7-76
- "Unicast MAC" on page 7-77
- "Wildcard" on page 7-78
- "Switch Port VLAN" on page 7-79

### VLAN Basic Settings

Figure 7-61. VLAN Basic Settings Page

The screenshot shows the SUPERMICR web interface for a SWITCH SBM-GEM-X2C. The 'Basic Settings' tab is selected. The main content area displays the 'VLAN Basic Settings' configuration table:

Garp System Control	Learning Mode	MAC Based On All Ports	Port and Protocol Based On All Ports	Dynamic Vlan Oper Status	Dynamic Multicast Oper Status	Maximum VLAN ID	Maximum Supported VLANs	Number of VLANs in the System
Start	IVL	Disabled	Enabled	Enabled	Enabled	4069	1024	1

Below the table is an 'Apply' button. A note at the bottom states: "Note : To Shutdown GARP, Dynamic Vlan & Dynamic Multicast should be disabled."

Clicking the BASIC SETTINGS tab brings up the VLAN BASIC SETTINGS page (Figure 7-61), which displays VLAN global configuration information. The parameters for this page are shown in Table 7-43.



Table 7-43. VLAN Basic Settings Page Parameters

Parameter	Description
Garp System Control	This parameter starts or shuts down GARP in the switch.
Learning Mode	This parameter specifies the Learning Mode ( <i>Independent, Shared, Hybrid</i> or <i>VLAN Learning</i> ).
VLAN Version	This parameter specifies the VLAN version supported.
Maximum VLAN ID	This parameter specifies the largest (4094) valid VLAN ID, which this switch can accept, above which all will be discarded.
Maximum Supported VLANs	This parameter specifies the maximum number of VLANs that this device can scale.
Number of VLANs in the System	This parameter specifies the active number of VLANs configured in the device.
MAC Based on All Ports	This parameter enables or disables the per Port MAC based classification.
Port and Protocol Based on all Ports	This parameter enables or disables the per Port Protocol based classification.

In addition, the BASIC SETTINGS page provides the configuration3 of Bridge Mode (*Customer /Provider*) and the priority of tunneled STP BPDUs. When you configure BRIDGE MODE TO PROVIDER, the Port Protocol based classification and MAC-based classification on all ports must be disabled.

### Port Settings

Figure 7-62. VLAN Port Settings Page

The screenshot shows the SUPERMICR switch management interface. At the top, there is a status bar with 'Refresh', 'Support', 'Help', 'About', and 'Log Out' buttons. Below this is a navigation menu with tabs for 'Basic Settings', 'Port Settings', 'Static VLANs', 'Protocol Group', 'Port Protocol', 'Port Map', 'Unicast Mac', 'Wildcard', and 'Switchport Filtering'. The 'Port Settings' tab is active, and the 'VLAN Port Settings' page is displayed for 'Gi0/1-Ex0/3'. The page contains a table with the following columns: 'Clear All', 'Select All', 'Port', 'MAC Based VLAN', 'Port and Protocol Based VLAN', 'PVID', 'Acceptable Frame Types', and 'Ingress Filtering'. The table lists 18 ports (Gi0/1 through Ex0/3) with their respective settings.

Clear All	Select All	Port	MAC Based VLAN	Port and Protocol Based VLAN	PVID	Acceptable Frame Types	Ingress Filtering
<input type="checkbox"/>	<input type="checkbox"/>	Gi0/1	Disabled	Enabled	1	All	Disabled
<input type="checkbox"/>	<input type="checkbox"/>	Gi0/2	Disabled	Enabled	1	All	Disabled
<input type="checkbox"/>	<input type="checkbox"/>	Gi0/3	Disabled	Enabled	1	All	Disabled
<input type="checkbox"/>	<input type="checkbox"/>	Gi0/4	Disabled	Enabled	1	All	Disabled
<input type="checkbox"/>	<input type="checkbox"/>	Gi0/5	Disabled	Enabled	1	All	Disabled
<input type="checkbox"/>	<input type="checkbox"/>	Gi0/6	Disabled	Enabled	1	All	Disabled
<input type="checkbox"/>	<input type="checkbox"/>	Gi0/7	Disabled	Enabled	1	All	Disabled
<input type="checkbox"/>	<input type="checkbox"/>	Gi0/8	Disabled	Enabled	1	All	Disabled
<input type="checkbox"/>	<input type="checkbox"/>	Gi0/9	Disabled	Enabled	1	All	Disabled
<input type="checkbox"/>	<input type="checkbox"/>	Gi0/10	Disabled	Enabled	1	All	Disabled
<input type="checkbox"/>	<input type="checkbox"/>	Gi0/11	Disabled	Enabled	1	All	Disabled
<input type="checkbox"/>	<input type="checkbox"/>	Gi0/12	Disabled	Enabled	1	All	Disabled
<input type="checkbox"/>	<input type="checkbox"/>	Gi0/13	Disabled	Enabled	1	All	Disabled
<input type="checkbox"/>	<input type="checkbox"/>	Gi0/14	Disabled	Enabled	1	All	Disabled
<input type="checkbox"/>	<input type="checkbox"/>	Gi0/15	Disabled	Enabled	1	All	Disabled
<input type="checkbox"/>	<input type="checkbox"/>	Gi0/16	Disabled	Enabled	1	All	Disabled
<input type="checkbox"/>	<input type="checkbox"/>	Ex0/1	Disabled	Enabled	1	All	Disabled
<input type="checkbox"/>	<input type="checkbox"/>	Ex0/2	Disabled	Enabled	1	All	Disabled
<input type="checkbox"/>	<input type="checkbox"/>	Ex0/3	Disabled	Enabled	1	All	Disabled

Clicking the PORT SETTINGS tab brings up the VLAN PORT SETTINGS page (Figure 7-62), which is used to associate the VLAN ID to the port for Port based VLAN classification.

While associating different ports to VLANs, you can also configure INGRESS FILTERING (at the port level) and ACCEPTABLE FRAME TYPES (accept *Tagged Frame Alone* or *All frames*).

The other configurations provided in this page are, enabling/disabling per Port MAC based classification and Port Protocol based classification, enabling/disabling of tunneling and enabling/disabling of STP BPDU Tunneling. To enable STP BPDU Tunneling on an interface, you must first enable tunneling on that interface.

## Static VLAN

Figure 7-63. Static VLAN Configuration Page

The screenshot displays the 'Static VLAN Configuration' page. At the top, there is a status bar with 'Speed' and 'Link' indicators for ports 1 through 24. Below this is a navigation menu with tabs: 'Basic Settings', 'Port Settings', 'Static VLANs' (highlighted), 'Protocol Group', 'Port Protocol', 'Port Mac Map', 'Unicast Mac', 'Wildcard', and 'Switchport Filtering'. The left sidebar contains a 'Home' menu with various system and network management options. The main content area features a 'Static VLAN Configuration' form with fields for 'VLAN ID', 'VLAN Name', 'Member Ports', 'Untagged Ports', and 'Forbidden Ports', along with 'Add' and 'Reset' buttons. Below the form is a table listing existing VLAN configurations.

Clear All	VLAN ID	VLAN Name	Member Ports	Untagged Ports	Forbidden Ports
Select All	1		Gi0/1-16.Ex0/1-3	Gi0/1-16.Ex0/1-3	

Clicking the STATIC VLANS tab brings up the STATIC VLAN CONFIGURATION page (Figure 7-63), which allows you to configure the VLAN related information statically.

Using the first table you can create new entries for uncreated VLANs. VLAN ID is the mandatory field in configuring a VLAN. You can also enter a VLAN NAME, MEMBER PORT LIST, UNTAGGED PORT and the FORBIDDEN PORTS for a VLAN.

The second table displays the VLAN configurations saved in the switch.

## Protocol Group

Figure 7-64. VLAN Protocol Group Settings Page

The screenshot shows the SUPERMICR web interface for a switch (SBM-GEM-X2C). The navigation menu includes tabs for SMIS, Basic Settings, Port Settings, Static VLANs, ProtocolGroup (selected), PortProtocol, PortMacMap, UnicastMac, Wildcard, and Switchportfiltering. The left sidebar lists various configuration categories like System Mgmt, Layer2 Mgmt, and Layer3 Mgmt. The main content area displays the 'VLAN Protocol Group Settings' page with the following form:

**VLAN Protocol Group Settings**

Frame Type: Enet-v2  
 Protocol Value: ARP  
 Group Identifier: [text field]  
 Add Reset

Clear All	Frame Type	Protocol Value	Group Identifier
Select All			

Delete

Clicking the PROTOCOL GROUP tab brings up the VLAN PROTOCOL GROUP SETTINGS page (Figure 7-64), which is used to map Protocol Templates to Protocol Group Identifiers.

The FRAME TYPE gives you the data-link encapsulation format. The PROTOCOL VALUE is the value of the protocol in a protocol template. The GROUP ID represents a group of protocols that are associated together.

## Port Protocol

Clicking the Port PROTOCOL tab brings up the PORT VLAN PROTOCOL SETTINGS page (not shown), which displays a table used for Port and Protocol based VLAN classification. The GROUP ID designates a group of protocols in the Protocol Group Database. The VLAN ID is the ID associated with a group of protocols for each port.

## Vlan Port MAC Map

Figure 7-65. VLAN Port MAC Map Settings Page

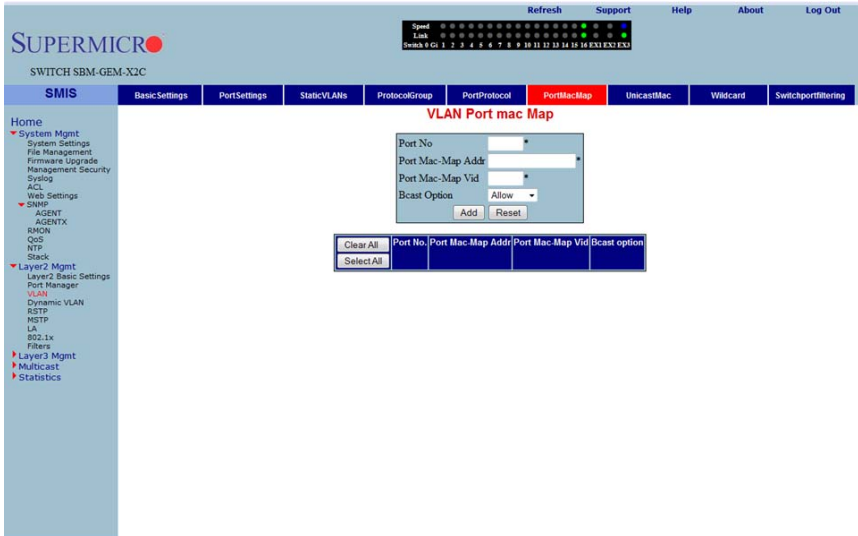

Clicking the PORT MAC MAP tab brings up the VLAN PORT MAC MAP page (Figure 7-65), which allows you to configure MAC based VLANs. The parameters for this page are shown in Table 7-44.

Table 7-44. VLAN Port MAC Map Page Parameters

Parameter	Description
Port No	This displays the port number.
Port Mac-Map Addr	This parameter specifies the Port MAC-Map address.
Port Mac-Map Vid	This parameter specifies the VLAN identifier for this MAC based VLAN
Bcast Option	This parameter specifies the Broadcast option, which can be allowed or discarded.

## Unicast MAC

Figure 7-66. VLAN Unicast MAC Settings Page

The screenshot shows the SUPERMICR SWITCH SBM\_GEM\_X2C web interface. At the top, there are links for Refresh, Support, Help, About, and Log Out. Below the navigation bar, the 'UnicastMac' tab is selected. The main content area is titled 'Vlan Unicast Mac Settings' and contains a table with the following data:

Clear All	Vlan ID	Mac Admin Status	Mac Limit	Mac Operational Status
Select All	1	Enabled	950	Enabled

Below the table are 'Apply' and 'Delete' buttons. The left sidebar shows a navigation menu with 'Unicast' selected under 'Layer2 Mgmt'.

Clicking the UNICAST MAC tab brings up the VLAN UNICAST MAC SETTINGS page (Figure 7-66), which allows you to configure the various parameters for VLAN Unicast MAC settings. The parameters for this page are shown in Table 7-45.

Table 7-45. VLAN Unicast Mac Settings Page Parameters

Parameter	Description
VLAN ID	This parameter specifies the VLAN Identifier.
MAC Admin Status	This parameter specifies the MAC administration status, which can be enabled or disabled.
MAC Limit	This parameter indicates the MAC limit.
MAC Operational Status	This parameter specifies the MAC operational Status, which can be enabled or disabled.

## Wildcard

Figure 7-67. Wildcard Settings Page

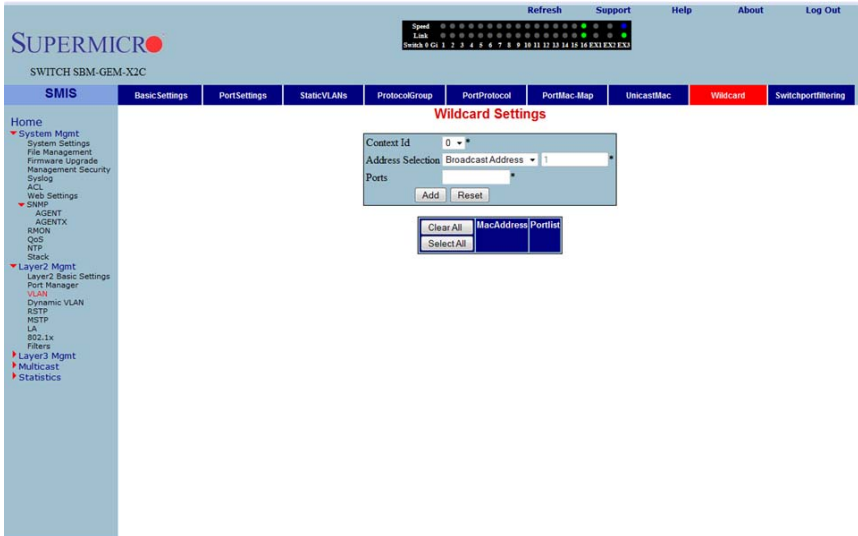

Clicking the WILDCARD tab brings up the WILDCARD SETTINGS page (Figure 7-67), which configures wildcard MAC addresses and ports for VLANs. The parameters for this page are shown in Table 7-46.

Table 7-46. Wildcard Settings Page Parameters

Parameter	Description
Content ID	This parameter allows you to select the CONTENT ID.
Address Selection	Use this parameter to select the address type.
Ports	This parameter allows you to enter a port.

## Switch Port VLAN

Figure 7-68. Switch Port Vlan Filtering Page

The screenshot shows the SUPERMICR web interface for a switch. The main navigation bar includes 'SMIS' and several configuration tabs: 'Basic Settings', 'Port Settings', 'Static VLANs', 'Protocol Group', 'Port Protocol', 'Port Mac-Map', 'Unicast Mac', 'Wildcard', and 'SwitchPort Filtering' (which is highlighted in red). The left sidebar contains a tree view of configuration options, with 'Layer2 Mgmt' expanded to show 'VLAN'. The main content area is titled 'SwitchPort Vlan Filtering' and shows a sub-header 'Gi0/1-Ex0/3'. Below this is a table with two columns: 'Vlan Port No.' and 'Utility Criteria'. Each row represents a port from Gi0/1 to Ex0/3. The 'Vlan Port No.' column has a checkbox next to each port name, and the 'Utility Criteria' column has a dropdown menu set to 'default'. At the top of the table are 'Clear All' and 'Select All' buttons. At the bottom of the table is an 'Apply' button.

Clicking the SWITCH PORT FILTERING tab brings up the SWITCHPORT VLAN FILTERING page (Figure 7-68), which configures utility criteria for SwitchPort Vlan filtering. The parameters for this page are shown in Table 7-47.

Table 7-47. SwitchPort Vlan Filtering Page Parameters

Parameter	Description
VLAN Port No.	This parameter displays the VLAN Port Number, which can be selected by the check box to the left of the column.
Utility Criteria	Use this parameter to select the utility criteria for the VLAN port selected.

## Dynamic Vlan

The Dynamic VLAN link allows you to configure the Dynamic VLAN information. Dynamic VLAN configuration information has been provided in the following pages

- "Dynamic VLAN Global Configuration" on page 7-80
- "Port Configuration" on page 7-81
- "GARP Timers" on page 7-82

### Dynamic VLAN Global Configuration

Figure 7-69. Dynamic VLAN Global Configuration Page

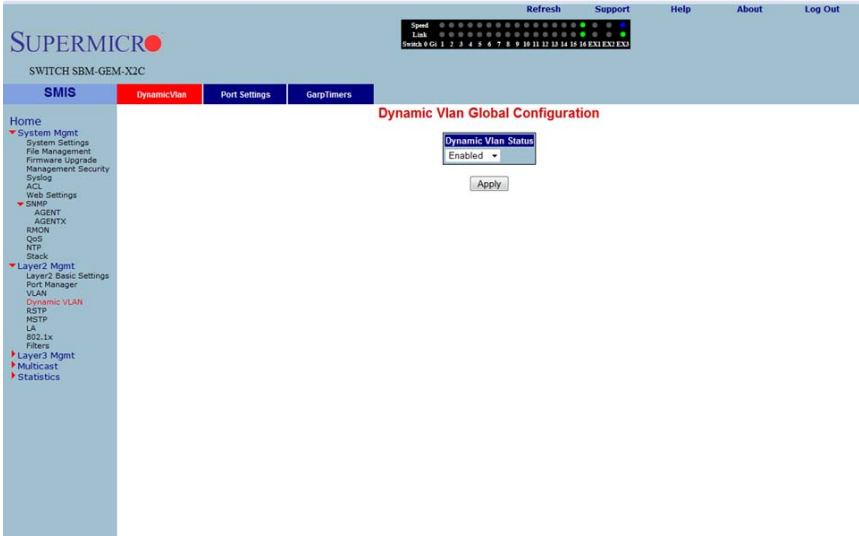

Clicking the DYNAMIC VLAN tab brings up the DYNAMIC VLAN GLOBAL CONFIGURATION page (Figure 7-69), which allows you to enable or disable Dynamic VLAN.



## Port Configuration

Figure 7-70. Dynamic VLAN Port Configuration Page

The screenshot shows the 'Dynamic Vlan Port Configuration' page. At the top, there are navigation links: Refresh, Support, Help, About, and Log Out. Below the navigation is a status bar with 'Speed' and 'Link' indicators. The main content area is titled 'Dynamic Vlan Port Configuration' and has a sub-header 'Gi0/1-Ex0/3'. Below this is a table with the following columns: 'Clear All', 'Select All', 'Port', 'Dynamic Vlan Status', and 'Restricted VLAN Registration'. The table contains 18 rows of ports, all with 'Enabled' status and 'Disabled' registration. An 'Apply' button is located at the bottom of the table.

Clear All	Port	Dynamic Vlan Status	Restricted VLAN Registration
<input type="checkbox"/>	Gi0/1	Enabled	Disabled
<input type="checkbox"/>	Gi0/2	Enabled	Disabled
<input type="checkbox"/>	Gi0/3	Enabled	Disabled
<input type="checkbox"/>	Gi0/4	Enabled	Disabled
<input type="checkbox"/>	Gi0/5	Enabled	Disabled
<input type="checkbox"/>	Gi0/6	Enabled	Disabled
<input type="checkbox"/>	Gi0/7	Enabled	Disabled
<input type="checkbox"/>	Gi0/8	Enabled	Disabled
<input type="checkbox"/>	Gi0/9	Enabled	Disabled
<input type="checkbox"/>	Gi0/10	Enabled	Disabled
<input type="checkbox"/>	Gi0/11	Enabled	Disabled
<input type="checkbox"/>	Gi0/12	Enabled	Disabled
<input type="checkbox"/>	Gi0/13	Enabled	Disabled
<input type="checkbox"/>	Gi0/14	Enabled	Disabled
<input type="checkbox"/>	Gi0/15	Enabled	Disabled
<input type="checkbox"/>	Gi0/16	Enabled	Disabled
<input type="checkbox"/>	Ex0/1	Enabled	Disabled
<input type="checkbox"/>	Ex0/2	Enabled	Disabled
<input type="checkbox"/>	Ex0/3	Enabled	Disabled

Clicking the PORT SETTINGS link brings up the DYNAMIC VLAN PORT CONFIGURATION page (Figure 7-70), which allows you to configure parameters for Dynamic VLAN ports. The parameters for this page are shown in Table 7-48.

Table 7-48. Dynamic VLAN Port Configuration Page Parameters

Parameter	Description
Port	This parameter displays the Port Number, which can be selected by the check box to the left of the column.
Dynamic VLAN Status	Use this parameter to enable/disable the DYNAMIC VLAN STATUS.
Restricted VLAN Registration	This parameter allows you to enable/disable RESTRICTED VLAN REGISTRATION.

## GARP Timers

Figure 7-71. Garp Timers Configuration Page

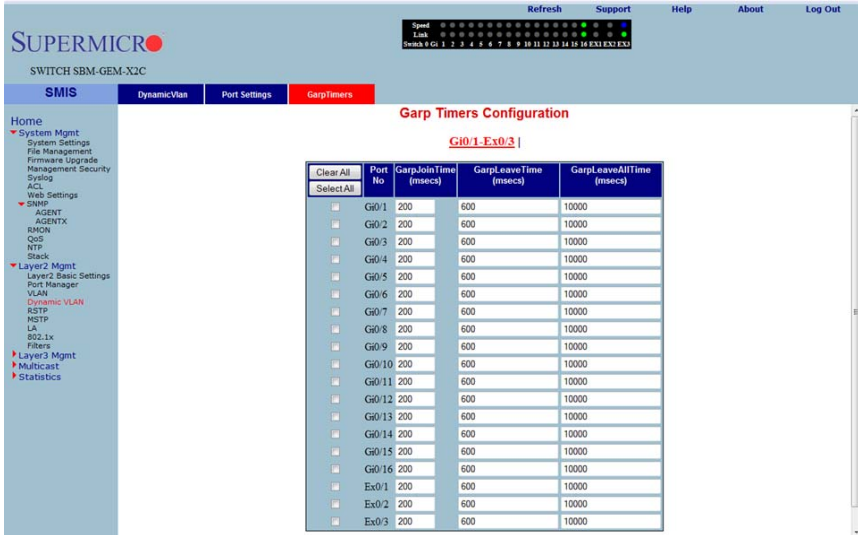

Clicking the GARP TIMERS tab brings up the GARP TIMERS CONFIGURATION page (Figure 7-71), which displays the various parameters for changing Garp times. The parameters for this page are shown in Table 7-49.

Table 7-49. Garp Timers Configuration Page Parameters

Parameter	Description
Port No	This parameter displays the Port Number.
Garp Join Time (msecs)	This parameter allows you to change the Garp Join Time.
Garp Leave Time (msecs)	This parameter allows you to change the Garp Leave Time.
Garp Leave All Time (msecs)	This parameter allows you to change the Garp Leave All Time.

## RSTP

The RSTP link provides links to the following configuration pages:

- "RSTP Global Settings" on page 7-83
- "RSTP Basic Settings" on page 7-84
- "Port Settings" on page 7-85
- "Port Status" on page 7-86

### RSTP Global Settings

Figure 7-72. Global Configuration Page

The screenshot shows the SUPERMICR web interface for a SWITCH SBM-GEM-X2C. The 'Global Settings' tab is selected. The 'Global Configuration' page displays a table with the following data:

Select	Context Id	System Control	Status	Dynamic Path Cost Calculation
0		Shutdown	Disabled	False

Below the table is an 'Apply' button. A note below the table reads: "Note : To enable RSTP Functionality, MSTP should be disabled and shutdown."

Clicking the GLOBAL SETTINGS tab brings up the GLOBAL CONFIGURATION page (Figure 7-72), which allows you to configure RSTP global parameters. The parameters for this page are shown in Table 7-50.

Table 7-50. Global Configuration Page Parameters

Parameter	Description
System Control	This parameter starts or Shutsdown RSTP in the switch.
Status	This parameter allows you to enable/disable the protocol at a global level on the switch.
Dynamic Path Cost Calculation	This parameter allows you to enable or disable the DYNAMIC PATH COST CALCULATION.

## RSTP Basic Settings

Figure 7-73. RSTP Configuration Page

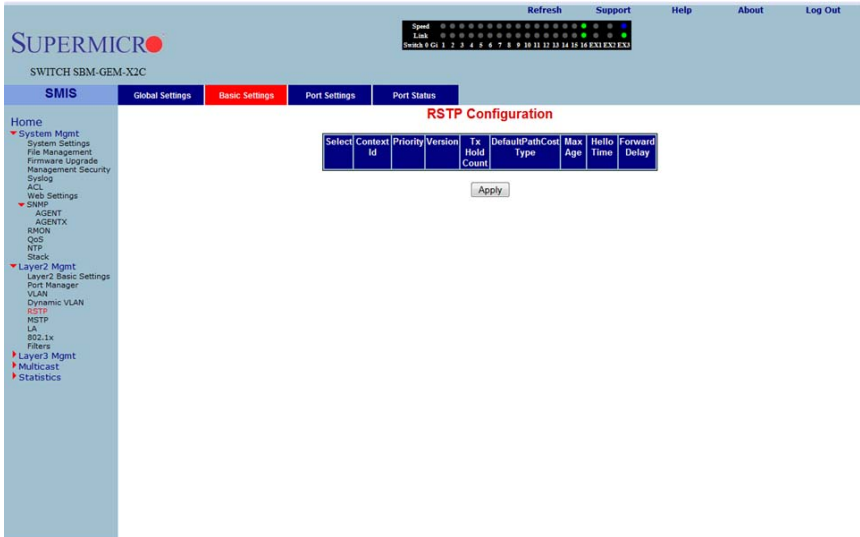

Clicking the BASIC SETTINGS tab brings up the RSTP CONFIGURATION page (Figure 7-73), which displays the various parameters for RSTP configuration. The parameters for this page are shown in Table 7-51.

Table 7-51. RSTP Configuration Page Parameters

Parameter	Description
System Control	This parameter allows you to start or shutdown RSTP in the switch.
RSTP Status	This parameter allows you to enable/disable the protocol at a global level on the switch.
Compatibility	This parameter allows you to choose to run the protocol as an RSTP or STP compatible version.
Bridge Priority	This parameter specifies the BRIDGE PRIORITY, which can be used to select the root bridge.
Transmit Hold Count	This parameter specifies the maximum number of packets that can be sent in a given interval. This is configured to avoid flooding.
Default Path Cost Version	This parameter allows you to configure the path cost either as a 16-bit value or a 32-bit value. This is provided mainly for backward compatibility with STAP.

## Port Settings

Figure 7-74. Port Status Configuration Page

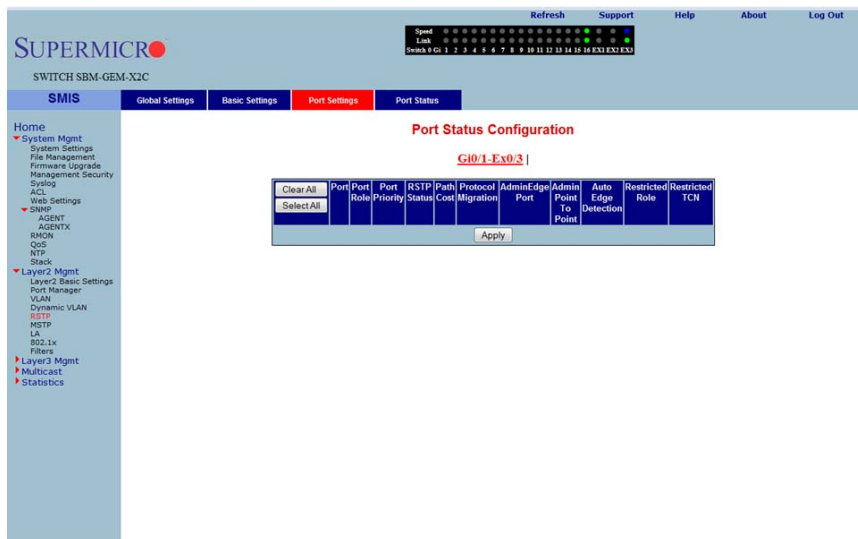

Clicking the PORT SETTINGS tab brings up the PORT STATUS CONFIGURATION page (Figure 7-74), which allows you to set the configuration per port related to RSTP. The parameters for this page are shown in Table 7-52.

Table 7-52. Port Status Configuration Page Parameters

Parameter	Description
Port	This parameter specifies the port identifier.
Status	This parameter enables or disables the RSTP protocol status on a particular port.
Priority	This parameter specifies the port priority used in role selection.
Path Cost	This parameter specifies the path cost associated with this port.
Protocol Migration	This parameter controls the migration from RSTP to STP, if the other side of the switch runs STP. The migration takes place only if this is <i>Enabled</i> .
PortFast	This parameter must be configured, if the corresponding port is an edge port.
Point-to-Point	This parameter allows you to configure ports explicitly as <i>Point-to-point</i> (Force true), <i>Non-point-to-point</i> or leave the decision to be made <i>Dynamically</i> (from the AL or MAC layer).
Auto Edge Status	If this parameter is set to <i>true</i> , the edge port status is dynamically calculated.

**Table 7-52. Port Status Configuration Page Parameters (Continued)**

Parameter	Description
Restricted Role	This parameter specifies the RESTRICTED ROLE status of the port.
Restricted TCN	This parameter indicates the RESTRICTED TCN status of the port.

**Port Status**

**Figure 7-75. RSTP Port Status Page**

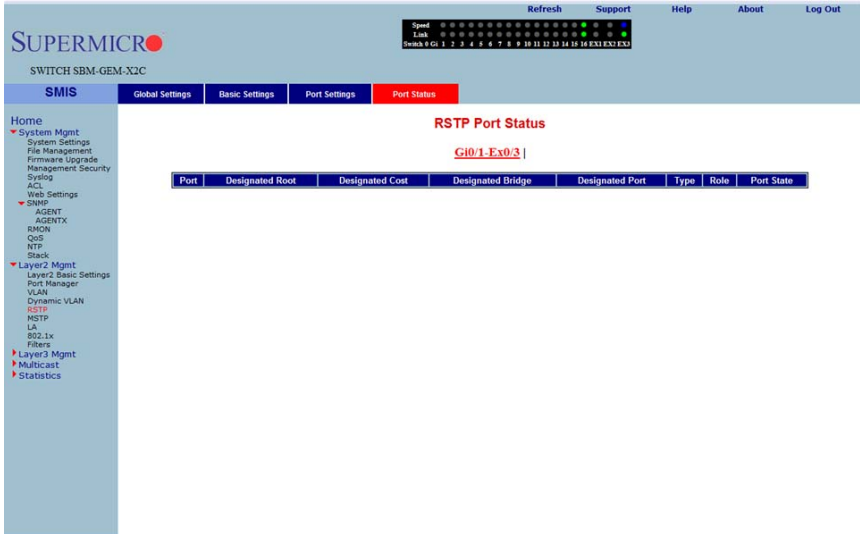

Clicking the PORT STATUS tab brings up the RSTP PORT STATUS page (Figure 7-75), which displays RSTP port specific information. The parameters for this page are shown in Table 7-53.

**Table 7-53. RSTP Port Status Page Parameters**

Parameter	Description
Designated Root	This parameter specifies the unique Bridge Identifier of the bridge that is recorded as the root for the segment to which the port is attached.
Designated Cost	This parameter specifies the path cost of the Designated Port of the segment connected to this port.
Designated Bridge	This parameter specifies the Bridge Identifier of the bridge, which this port considers to be the Designated Bridge for this port's segment.
Designated Port	This parameter specifies the Port Identifier of the port on the Designated Bridge for this port's segment.

Table 7-53. RSTP Port Status Page Parameters (Continued)

Parameter	Description
Type	This parameter specifies the operational point-to-point status of the LAN segment attached to this port. It indicates whether a port is considered to have a <i>Point-to-point</i> connection or <i>Shared Media</i> .
Role	This parameter specifies the port's current role as defined by the Spanning Tree Protocol.
Port State	This parameter specifies the port's current state as defined by application of the Spanning Tree Protocol.

## MSTP

The MSTP link leads you to the following configuration pages:

- "MSTP Basic Settings" on page 7-87
- "MSTP Timers" on page 7-89
- "Port Configuration" on page 7-90
- "VLAN Mapping" on page 7-91
- "Port Settings" on page 7-92
- "CIST Port Status" on page 7-93

## MSTP Basic Settings

Figure 7-76. Global Configuration Page

Refresh Support Help About Log Out

Speed Link

Switch 0 Gi 1 2 3 4 5 6 7 8 9 10 11 12 13 14 15 16 EX1 EX2 EX3

SUPERMICR SWITCH SBM-GEM-X2C

SMIS Basic Settings Timers Port Configuration VLAN Mapping Port Settings CIST Port Status

Home

- System Mgmt
  - System Settings
  - File Management
  - Firmware Upgrade
  - Management Security
  - Snmp
  - ACL
  - Web Settings
  - SNMP
    - AGENT
    - AGENTX
    - RMON
    - QoS
    - NTP
    - Stack
- Layer2 Mgmt
  - Layer2 Basic Settings
  - Port Manager
  - VLAN
  - Dynamic VLAN
  - RSTP
  - RSTP
  - LA
  - BQ2 Lx
  - Filters
- Layer3 Mgmt
- Multicast
- Statistics

Global Configuration

Select	Context Id	System Control	MSTP Status	Maximum MST Instances	Bridge Priority	Path Cost Type	Protocol Version	Region Name	Region Version	Dynamic Path Cost Calculation
o	0	Start	Enabled	16	32768	32 Bit	MSTP	00:30:48:a3:00:03	0	False

Apply

Note : To enable MSTP Functionality, RSTP should be disabled and shutdown.

Clicking the **BASIC SETTINGS** tab brings up the **GLOBAL CONFIGURATION** page (Figure 7-76), which can access the MSTP global configuration. The parameters for this page are shown in Table 7-54.

**Table 7-54. Global Configuration Page Parameters**

Parameter	Description
System Control	This parameter <i>Starts</i> or <i>Shutsdown</i> MSTP in the switch.
MSTP Status	This parameter specifies the protocol that can be enabled/disabled at a global level on the switch using this field.
Compatibility	This parameter allows you to choose to run the protocol in <i>MSTP</i> , <i>RSTP</i> or an <i>STP</i> compatible version.
Bridge Priority	This parameter specifies the Priority value assigned to the bridge that is used to select the root bridge.
Transmit Hold Count	This parameter specifies the maximum number of packets that can be sent in a given interval. This is configured to avoid flooding.
Default Path Cost Version	This parameter allows you to configure the path cost either as a <i>16-bit</i> value or a <i>32-bit</i> value. This is provided mainly for backward compatibility with STAP.
Maximum Age (Seconds)	This parameter specifies the time period for which the information received in the RSTP BPDU is valid.
Forward Delay (Seconds)	This parameter specifies how fast a port changes its Spanning state when moving towards the Forwarding state.
Hop Counts (Seconds)	This parameter specifies the maximum number of bridges that a packet can cross before it will be dropped, to avoid infinite looping of the packets.
Region Name	This parameter specifies the name for the Region's configuration. By default, the region name will be equal to the Bridge MAC Address.
Region Version	This parameter specifies the version number of the configuration to be used.



## MSTP Timers

Figure 7-77. Timers Configuration Page

The screenshot shows the SUPERMICR web interface for a switch (SWITCH SBM-GEM-X2C). The 'Timers' tab is selected in the navigation menu. The 'Timers Configuration' page displays a table with the following data:

Maximum Hop Count	Max Age	Forward Delay	Transmit Hold Count	Hello Time
20	20	15	3	2

An 'Apply' button is located below the table. The left sidebar contains a navigation menu with options like Home, System Mgmt, Layer2 Mgmt, and Layer3 Mgmt.

Clicking the TIMERS tab brings up the TIMERS CONFIGURATION page (Figure 7-77), which configures the time for MAXIMUM HOP COUNT, FORWARD DELAY, MAXIMUM AGE, TRANSMIT HOLD AGE and HELLO TIME.

Port Configuration

Figure 7-78. CIST Settings Page

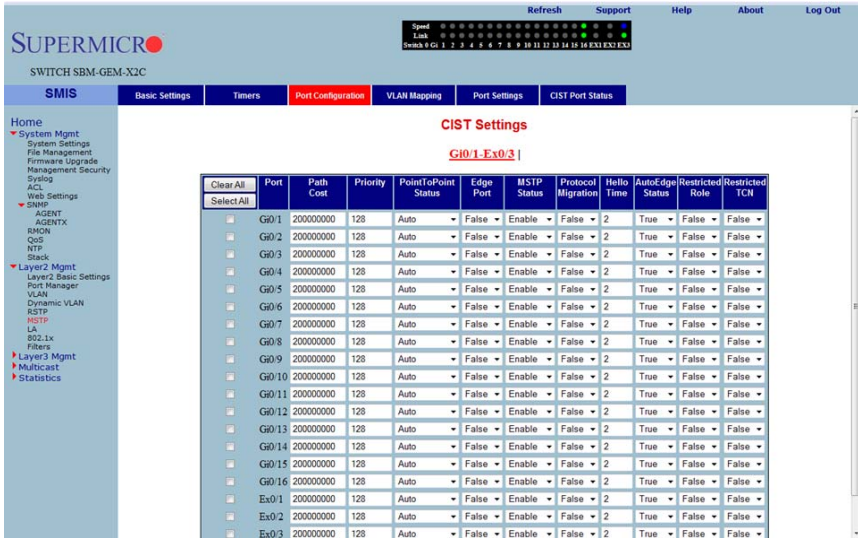

Clicking the PORT CONFIGURATION tab brings up the CIST SETTINGS page (Figure 7-78), which sets the configuration per Port related to MSTP. The parameters for this page are shown in Table 7-55.

Table 7-55. CIST Settings Page Parameters

Parameter	Description
Port	This parameter specifies the port identifier.
Admin Status	This parameter specifies the MSTP protocol status that can be enabled/disabled on the particular port.
Priority	This parameter specifies the port priority used in role selection.
Path Cost	This parameter specifies the path cost associated with this port.
Protocol Migration	This parameter controls the migration among MSTP, RSTP and STP protocols, if the other side of the switch runs a different mode. Migration takes place only if this is enabled.
Edge Status	This parameter must be configured if the corresponding port is an edge port.
Point-to-Point Status	This parameter allows you to configure the ports explicitly as point-to-point ( <i>Force true</i> ), as a non-point-to-point port, or leave the decision to be made dynamically (from the AL or MAC layer).
Hello Time (Seconds)	This parameter specifies the administrative value of Hello Time for the port.

Table 7-55. CIST Settings Page Parameters (Continued)

Parameter	Description
Auto Edge Status	If set to <i>True</i> , the edge port status will be dynamically calculated.
Restricted Role	This parameter specifies the Restricted role status of the port.
Restricted TCN	This parameter indicates the Restricted TCN status of the port.

## VLAN Mapping

Figure 7-79. VLAN Mapping Page

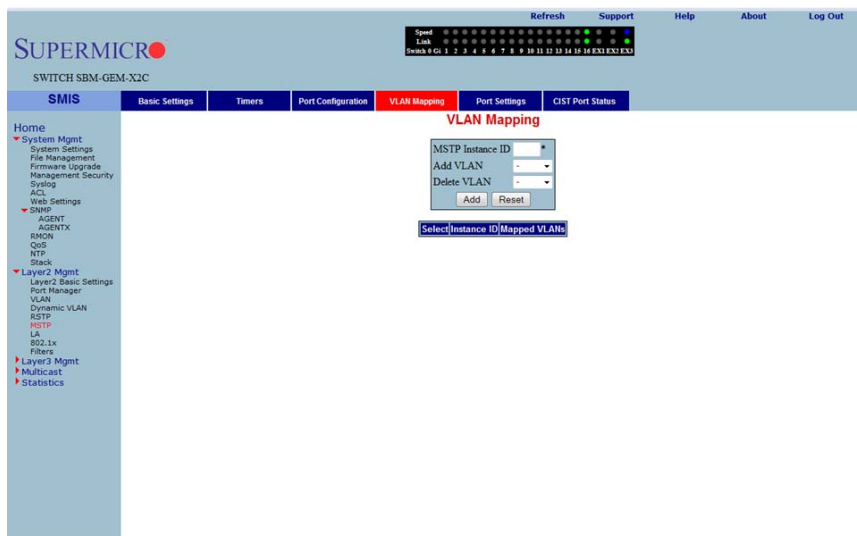

Clicking the VLAN MAPPING tab brings up the VLAN MAPPING page (Figure 7-79), whose table contains one entry for each instance of MSTP. The parameters for this page are shown in Table 7-56.

Table 7-56. VLAN Mapping Page Parameters

Parameter	Description
MSTP Instance ID	This parameter specifies the Instance ID, which is the index of the table.
Map VLAN	This parameter specifies the list of VLANs to be mapped to this instance of the spanning tree.
Unmap VLAN	This parameter specifies the list of VLANs to be unmapped from this instance of the spanning tree.

## Port Settings

Figure 7-80. Port Settings Page

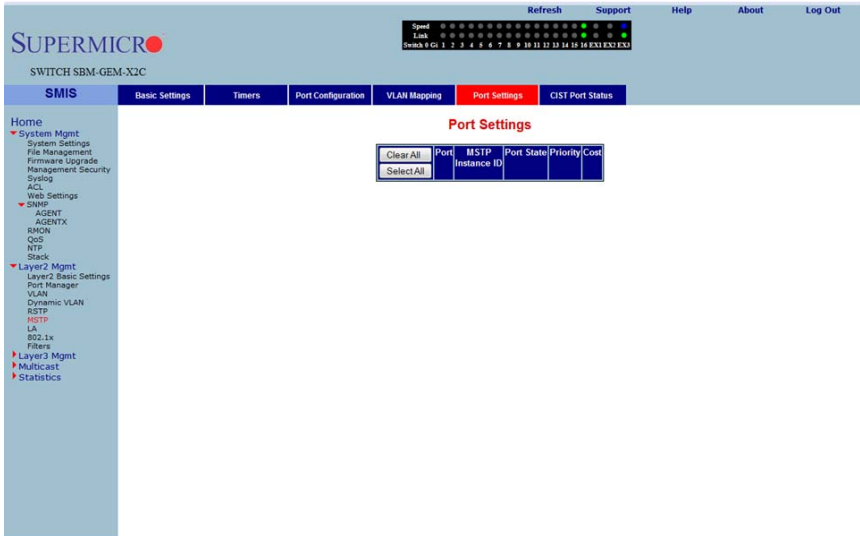

Clicking the PORT SETTINGS tab brings up the PORT SETTINGS page (Figure 7-80), which displays the various parameters for port settings. The parameters for this page are shown in Table 7-57.

Table 7-57. Port Settings Page Parameters

Parameter	Description
Port	This parameter specifies the interface index of the port on which MSTP is being run.
MSTP Instance ID	This parameter specifies the instance ID of the STP that is associated with this instance.
Port State	This parameter specifies the current state of the port.
Priority	This parameter specifies the priority related to this port.
Cost	This parameter specifies the cost associated with this port, which will be added to the cost of any path that includes this port.

## CIST Port Status

Figure 7-81. MSTP CIST Port Status Page

The screenshot shows the SUPERMICR SWITCH S8M-GEM-X2C web interface. The 'CIST Port Status' tab is selected, displaying the 'MSTP CIST Port Status' page. A status bar at the top indicates 'Gi0/1-Ex0/3'. Below the navigation tabs, a table lists the status for various ports.

Port	Designated Root	Root Priority	Designated Bridge	Designated Port	Designated Cost	Regional Root	Regional Root Priority	Regional Path Cost	Type	Role	Port State
Gi0/1	80.000.00.30.48.a3.00.03	32768	80.000.00.30.48.a3.00.03	80.01	0	80.000.00.30.48.a3.00.03	32768	0	Shared_Lan	Disabled	Discarding
Gi0/2	80.000.00.30.48.a3.00.03	32768	80.000.00.30.48.a3.00.03	80.02	0	80.000.00.30.48.a3.00.03	32768	0	Shared_Lan	Disabled	Discarding
Gi0/3	80.000.00.30.48.a3.00.03	32768	80.000.00.30.48.a3.00.03	80.03	0	80.000.00.30.48.a3.00.03	32768	0	Shared_Lan	Disabled	Discarding
Gi0/4	80.000.00.30.48.a3.00.03	32768	80.000.00.30.48.a3.00.03	80.04	0	80.000.00.30.48.a3.00.03	32768	0	Shared_Lan	Disabled	Discarding
Gi0/5	80.000.00.30.48.a3.00.03	32768	80.000.00.30.48.a3.00.03	80.05	0	80.000.00.30.48.a3.00.03	32768	0	Shared_Lan	Disabled	Discarding
Gi0/6	80.000.00.30.48.a3.00.03	32768	80.000.00.30.48.a3.00.03	80.06	0	80.000.00.30.48.a3.00.03	32768	0	Shared_Lan	Disabled	Discarding
Gi0/7	80.000.00.30.48.a3.00.03	32768	80.000.00.30.48.a3.00.03	80.07	0	80.000.00.30.48.a3.00.03	32768	0	Shared_Lan	Disabled	Discarding
Gi0/8	80.000.00.30.48.a3.00.03	32768	80.000.00.30.48.a3.00.03	80.08	0	80.000.00.30.48.a3.00.03	32768	0	Shared_Lan	Disabled	Discarding
Gi0/9	80.000.00.30.48.a3.00.03	32768	80.000.00.30.48.a3.00.03	80.09	0	80.000.00.30.48.a3.00.03	32768	0	Shared_Lan	Disabled	Discarding
Gi0/10	80.000.00.30.48.a3.00.03	32768	80.000.00.30.48.a3.00.03	80.0a	0	80.000.00.30.48.a3.00.03	32768	0	Shared_Lan	Disabled	Discarding
Gi0/11	80.000.00.30.48.a3.00.03	32768	80.000.00.30.48.a3.00.03	80.0b	0	80.000.00.30.48.a3.00.03	32768	0	Shared_Lan	Disabled	Discarding
Gi0/12	80.000.00.30.48.a3.00.03	32768	80.000.00.30.48.a3.00.03	80.0c	0	80.000.00.30.48.a3.00.03	32768	0	Shared_Lan	Disabled	Discarding
Gi0/13	80.000.00.30.48.a3.00.03	32768	80.000.00.30.48.a3.00.03	80.0d	0	80.000.00.30.48.a3.00.03	32768	0	Shared_Lan	Disabled	Discarding
Gi0/14	80.000.00.30.48.a3.00.03	32768	80.000.00.30.48.a3.00.03	80.0e	0	80.000.00.30.48.a3.00.03	32768	0	Shared_Lan	Disabled	Discarding
Gi0/15	80.000.00.30.48.a3.00.03	32768	80.000.00.30.48.a3.00.03	80.0f	0	80.000.00.30.48.a3.00.03	32768	0	Shared_Lan	Disabled	Discarding
Gi0/16	80.000.00.30.48.90.00.e2	32768	80.000.00.30.48.a3.00.03	80.10	200000000	80.000.00.30.48.a3.00.03	32768	0	PointToPoint	Designated Forwarding	
Ex0/1	80.000.00.30.48.a3.00.03	32768	80.000.00.30.48.a3.00.03	80.19	0	80.000.00.30.48.a3.00.03	32768	0	Shared_Lan	Disabled	Discarding
Ex0/2	80.000.00.30.48.a3.00.03	32768	80.000.00.30.48.a3.00.03	80.1a	0	80.000.00.30.48.a3.00.03	32768	0	Shared_Lan	Disabled	Discarding
Ex0/3	80.000.00.30.48.90.00.e2	32768	80.000.00.30.48.90.00.e2	80.1b	0	80.000.00.30.48.a3.00.03	32768	0	PointToPoint	Root	Forwarding

Clicking the CIST PORT STATUS tab brings up the MSTP CIST PORT STATUS page (Figure 7-81), which displays MSTP CIST port specific information. The parameters for this page are shown in Table 7-58.

Table 7-58. MSTP CIST Port Status Page Parameters

Parameter	Description
Designated Root	This parameter specifies the unique Bridge Identifier of the Bridge recorded as the Root for the segment to which the port is attached.
Designated Bridge	This parameter specifies the Bridge Identifier of the bridge, which this port considers to be the Designated Bridge for this port's segment.
Designated Port	This parameter specifies the Port Identifier of the port on the Designated Bridge for this port's segment.
Designated Cost	This parameter specifies the path cost of the Designated Port of the segment connected to this port.
Regional Root	This parameter specifies the unique Bridge Identifier of the bridge recorded as the CIST Regional Root Identifier in the configuration BPDUs transmitted.
Regional Path Cost	This parameter specifies the contribution of this port to the path cost of paths towards the CIST Regional Root, which includes this port.
Type	This parameter specifies the operational point-to-point status of the LAN segment attached to this port. It indicates whether a port is considered to have a point-to-point connection or shared media.

**Table 7-58. MSTP CIST Port Status Page Parameters (Continued)**

<b>Parameter</b>	<b>Description</b>
Role	This parameter specifies the ports current role as defined by the Spanning Tree Protocol.
Port State	This parameter specifies the port's current state as defined by the application of the Spanning Tree Protocol.

## LA (Link Aggregation)

The LA link provides links to the following configuration pages:

- "LA Basic Settings" on page 7-95
- "Interface Settings" on page 7-96
- "Port Channel" on page 7-97
- "Port Settings" on page 7-98
- "Port State Info" on page 7-99
- "Load Balancing" on page 7-100

### LA Basic Settings

Figure 7-82. LA Basic Settings Page

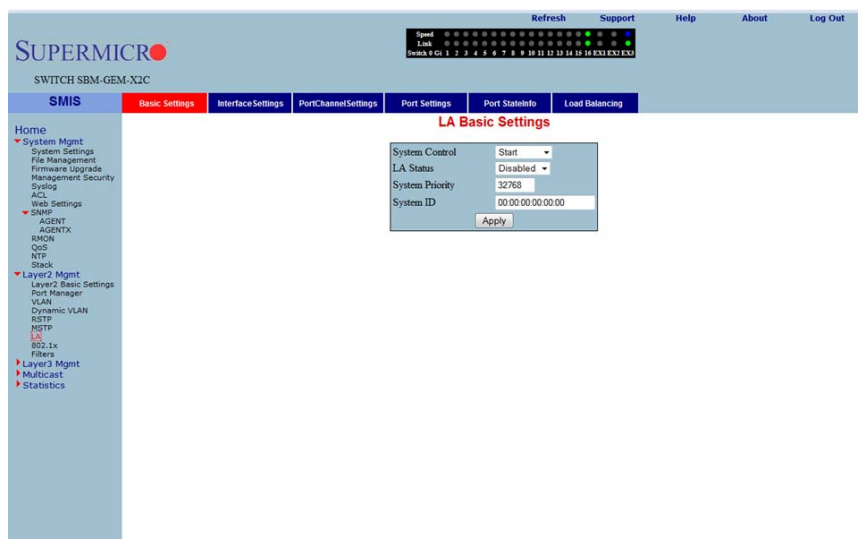

Clicking the BASIC SETTINGS tab brings up the LA BASIC SETTINGS page (Figure 7-82), which displays the various parameters for LA basic settings. The parameters for this page are shown in Table 7-59.

Table 7-59. LA Basic Settings Page Parameters

Parameter	Description
System Control	This parameter <i>Starts</i> or <i>Shutsdown</i> LA in the switch.
LA Status	This is used to enable or disable LA in the switch.

**Table 7-59. LA Basic Settings Page Parameters (Continued)**

Parameter	Description
System Priority	This parameter specifies the priority value associated with the Actor's system ID.
System ID	This parameter specifies the Bridge MAC Address that is displayed. This is a read-only parameter.

**Interface Settings**

**Figure 7-83. Port Channel Interface Basic Settings Page**

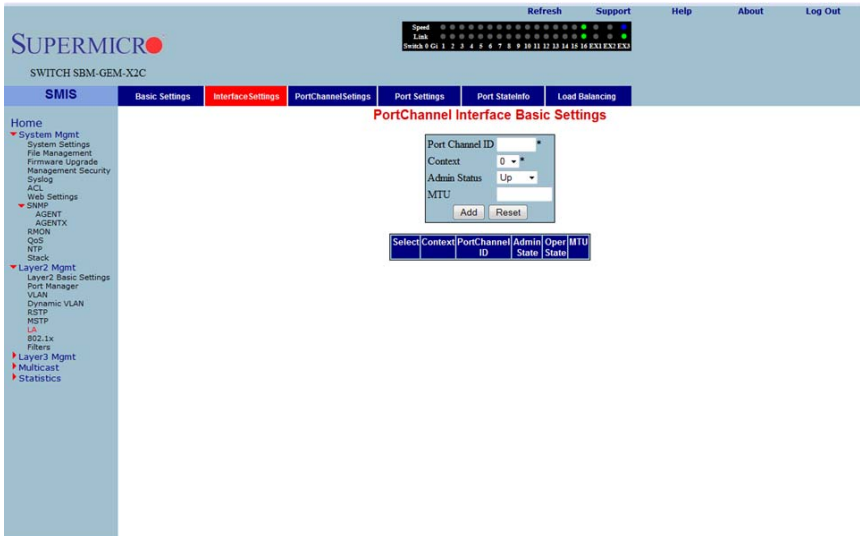

Clicking the INTERFACE SETTINGS tab brings up the PORT CHANNEL INTERFACE BASIC SETTINGS page (Figure 7-83), which allows you to configure port channels. The parameters for this page are shown in Table 7-60.

**Table 7-60. Port Channel Interface Basic Settings Page Parameters**

Parameter	Description
Port Channel ID	This parameter specifies the identifier of the port channel interface. The valid values are between 1 to 65535.
Admin Status	This parameter administratively makes the port channel Up or Down.
MTU	This parameter specifies the MTU value for this port channel.



## Port Channel

Figure 7-84. LA Port Channel Settings Page

The screenshot displays the 'LA Port Channel Settings' page in the SUPERMICR web interface. The page features a navigation menu on the left with categories like 'System Mgmt', 'Layer2 Mgmt', and 'Layer3 Mgmt'. The main content area contains a configuration form with the following fields: 'Port Channel ID' (dropdown), 'Aggregation Type' (Static), 'Action Type' (Add), 'Mode' (Lacp), 'Ports' (text input), 'DefaultPort' (text input), 'MAC Selection' (dropdown), and 'Force MAC' (checkbox). Below the form is a table with the following columns: 'Select', 'Context', 'Port Channel', 'Ports', 'NoOf Ports Per Channel', 'NoOf Hotstandby Ports', 'Default Port', 'MAC Selection', and 'Force MAC'.

Clicking the PORT CHANNEL SETTINGS tab brings up the LA PORT CHANNEL SETTINGS page (Figure 7-84), which is used to edit the Port Channel configuration. The first table is for creating Port Channel interfaces while the second table is for editing the Port Channel configuration. The third table is used to display the Port Channels and to delete the existing Port Channels.

The parameters for this page are shown in Table 7-61.

Table 7-61. LA Port Channel Settings Page Parameters

Parameter	Description
Port Channel ID	This parameter specifies the identifier of the port channel interface.
Action Type	This parameter specifies whether the port channel must be created or deleted.
Ports	This parameter specifies the interface indices that must be configured to be members of the Port Channel.
MAC Selection	This parameter specifies the mode by which the MAC address for the port channel is assigned. It can be dynamic or the user can <i>Force</i> the selection of a specific MAC address.
Force MAC	This parameter specifies the MAC Address that is assigned to the port channel. For this, the MAC selection mode must be <i>Force</i> .

## Port Settings

Figure 7-85. LA Port Settings Page

The screenshot shows the 'LA Port Settings' page for a Superblade Network Module. The page title is 'LA Port Settings' and it displays a table of port configurations for the interface 'Gi0\_1-Ex0\_3'. The table has the following columns: Clear All, Select All, Port, Port Priority, Port Identifier, Mode, Activity, Timeout, Wait Time (secs), Bundle State, and Aggregation Selection. The table lists 27 ports, all of which are currently in a 'Down' state. The ports are numbered 1 through 27, with the first 16 being Gi0/1 through Gi0/16 and the last three being Ex0/1 through Ex0/3.

Clear All	Port	Port Priority	Port Identifier	Mode	Activity	Timeout	Wait Time (secs)	Bundle State	Aggregation Selection
Select All	Gi0/1	128	1	Disable	Active	Long	2	Down	Static
	Gi0/2	128	2	Disable	Active	Long	2	Down	Static
	Gi0/3	128	3	Disable	Active	Long	2	Down	Static
	Gi0/4	128	4	Disable	Active	Long	2	Down	Static
	Gi0/5	128	5	Disable	Active	Long	2	Down	Static
	Gi0/6	128	6	Disable	Active	Long	2	Down	Static
	Gi0/7	128	7	Disable	Active	Long	2	Down	Static
	Gi0/8	128	8	Disable	Active	Long	2	Down	Static
	Gi0/9	128	9	Disable	Active	Long	2	Down	Static
	Gi0/10	128	10	Disable	Active	Long	2	Down	Static
	Gi0/11	128	11	Disable	Active	Long	2	Down	Static
	Gi0/12	128	12	Disable	Active	Long	2	Down	Static
	Gi0/13	128	13	Disable	Active	Long	2	Down	Static
	Gi0/14	128	14	Disable	Active	Long	2	Down	Static
	Gi0/15	128	15	Disable	Active	Long	2	Down	Static
	Gi0/16	128	16	Disable	Active	Long	2	Down	Static
	Ex0/1	128	25	Disable	Active	Long	2	Down	Static
	Ex0/2	128	26	Disable	Active	Long	2	Down	Static
	Ex0/3	128	27	Disable	Active	Long	2	Down	Static

Clicking the PORT SETTINGS tab brings up the LA PORT SETTINGS page (Figure 7-85), which configures LA properties at a per-port level. The parameters for this page are shown in Table 7-62.

Table 7-62. LA Port Settings Page Parameters

Parameter	Description
Port	This parameter specifies the Interface Index.
Port Priority	This parameter specifies the priority value of the Port.
Mode	This parameter specifies the various port modes, such as <i>LACP</i> , <i>Manual</i> or <i>Disable</i> .
Activity	This parameter specifies whether the Port LACP activity is <i>Active</i> or <i>Passive</i> .
Timeout	This parameter sets the time within which LACP PDUs must be received on a port to avoid timing out of the Aggregated Link. If a <i>Long</i> timeout is chosen then the ports will time out of the Port Channel in 90-seconds. If a <i>Short</i> timeout is chosen then the ports will time out of the Port Channel in 3-seconds.

Table 7-62. LA Port Settings Page Parameters (Continued)

Parameter	Description
Wait Time	This parameter configures the waiting time for a port after receiving Partner information and before entering aggregation.
Bundle State	<p>This parameter indicates the current state of the port with respect to Link Aggregation. The possible states are:</p> <ul style="list-style-type: none"> <li>• <b>Up in Bundle</b> - The port is an active member of the port channel.</li> <li>• <b>Up Individual</b> - The port is not a member of any port channel but its Oper-Status is Up.</li> <li>• <b>Standby</b> - The port is a member of the port channel but is currently in a standby state.</li> <li>• <b>Down</b> - The port's Oper-Status is Down.</li> </ul>

### Port State Info

Figure 7-86. LA Port State Machine Information Page

The screenshot shows the SUPERMICR web interface for a SWITCH SBM-GEM-X2C. The top navigation bar includes 'Refresh', 'Support', 'Help', 'About', and 'Log Out'. The main navigation tabs are 'Basic Settings', 'Interface Settings', 'PortChannel Settings', 'Port Settings', 'Port StateInfo' (highlighted in red), and 'Load Balancing'. The left sidebar menu includes 'Home', 'System Mgmt', 'File Management', 'Management Security', 'Snmp', 'AGENT', 'AGENTX', 'RMON', 'QoS', 'NTP', 'Stack', 'Layer2 Mgmt', 'Layer2 Basic Settings', 'Port Manager', 'VLAN', 'Dynamic VLAN', 'RSTP', 'NSTP', 'L2', '802.1x', 'Filters', 'Layer3 Mgmt', 'Multicast', and 'Statistics'. The main content area displays the title 'LA Port StateMachine Information' and a sub-header 'Port Channel|Port No|Aggregation State'.

Clicking the PORT STATE INFO tab brings up the LA PORT STATE MACHINE INFORMATION page (Figure 7-86), which displays Link Aggregation state machine information. It displays the aggregation state information for every port channel.

## Load Balancing

Figure 7-87. LA Load Balancing Policy Page



Clicking the LOAD BALANCING tab brings up the LA LOAD BALANCING POLICY page (Figure 7-87), which allows you to choose the selection policy for load distribution on the aggregated links.

The selection policy can be one of the following - Source MAC based, Destination MAC based, both Source and Destination MAC, Source IP address, Destination IP address or both IP addresses.

## 802.1x

The 802.1x link provides link to the following configuration pages:

- "Basic Settings" on page 7-101
- "Port Settings" on page 7-102
- "Timers" on page 7-104
- "Local AS" on page 7-105
- "MAC Session Info" on page 7-106

### Basic Settings

Figure 7-88. 802.1x Basic Settings Page

Clicking the BASIC SETTINGS tab brings up the 802.1x BASIC SETTINGS page (Figure 7-88), which displays the various 802.1x Basic Settings parameters. The parameters for this page are shown in Table 7-63.

Table 7-63. 802.1x Basic Settings Page Parameters

Parameter	Description
System Control	This parameter starts or shutdowns 802.1x in the switch.
802.1x Authentication	This parameter allows enabling or disabling of the 802.1x based port security feature in the switch.

Table 7-63. 802.1x Basic Settings Page Parameters (Continued)

Parameter	Description
Authentication Server	This parameter specifies the Authentication Server Location as <i>Remote</i> or <i>Local</i> .
Network Access Server ID	This parameter specifies the Authenticator ID, which originates the Access-Request Packets.

**Port Settings**

Figure 7-89. 802.1x Port Settings Page

The screenshot shows the '802.1x Port Settings' page for a Superblade switch. The interface includes a navigation menu on the left with options like 'System Mgmt', 'Layer2 Mgmt', and 'Layer3 Mgmt'. The main content area displays a table of port settings. The table has the following columns: Clear All, Select All, Port, Port Control, Access Control, Auth Port Status, Supp Port Status, Authentication Mode, Configured Control Direction, Operational Control Direction, Auth SM State, Supp SM State, and Auth. The table lists 18 ports: G10.1 through G10.16 and Ex0.1 through Ex0.2. Each row shows the port name, its control status (e.g., ForceAuthorized, INACTIVE), and various status indicators.

Clear All	Select All	Port	Port Control	Access Control	Auth Port Status	Supp Port Status	Authentication Mode	Configured Control Direction	Operational Control Direction	Auth SM State	Supp SM State	Auth
<input type="checkbox"/>	<input type="checkbox"/>	G10.1	ForceAuthorized	INACTIVE	Authorized	Unauthorized	Port Based	Both	Both	Initialize	Disconnected	Fail
<input type="checkbox"/>	<input type="checkbox"/>	G10.2	ForceAuthorized	INACTIVE	Authorized	Unauthorized	Port Based	Both	Both	Initialize	Disconnected	Fail
<input type="checkbox"/>	<input type="checkbox"/>	G10.3	ForceAuthorized	INACTIVE	Authorized	Unauthorized	Port Based	Both	Both	Initialize	Disconnected	Fail
<input type="checkbox"/>	<input type="checkbox"/>	G10.4	ForceAuthorized	INACTIVE	Authorized	Unauthorized	Port Based	Both	Both	Initialize	Disconnected	Fail
<input type="checkbox"/>	<input type="checkbox"/>	G10.5	ForceAuthorized	INACTIVE	Authorized	Unauthorized	Port Based	Both	Both	Initialize	Disconnected	Fail
<input type="checkbox"/>	<input type="checkbox"/>	G10.6	ForceAuthorized	INACTIVE	Authorized	Unauthorized	Port Based	Both	Both	Initialize	Disconnected	Fail
<input type="checkbox"/>	<input type="checkbox"/>	G10.7	ForceAuthorized	INACTIVE	Authorized	Unauthorized	Port Based	Both	Both	Initialize	Disconnected	Fail
<input type="checkbox"/>	<input type="checkbox"/>	G10.8	ForceAuthorized	INACTIVE	Authorized	Unauthorized	Port Based	Both	Both	Initialize	Disconnected	Fail
<input type="checkbox"/>	<input type="checkbox"/>	G10.9	ForceAuthorized	INACTIVE	Authorized	Unauthorized	Port Based	Both	Both	Initialize	Disconnected	Fail
<input type="checkbox"/>	<input type="checkbox"/>	G10.10	ForceAuthorized	INACTIVE	Authorized	Unauthorized	Port Based	Both	Both	Initialize	Disconnected	Fail
<input type="checkbox"/>	<input type="checkbox"/>	G10.11	ForceAuthorized	INACTIVE	Authorized	Unauthorized	Port Based	Both	Both	Initialize	Disconnected	Fail
<input type="checkbox"/>	<input type="checkbox"/>	G10.12	ForceAuthorized	INACTIVE	Authorized	Unauthorized	Port Based	Both	Both	Initialize	Disconnected	Fail
<input type="checkbox"/>	<input type="checkbox"/>	G10.13	ForceAuthorized	INACTIVE	Authorized	Unauthorized	Port Based	Both	Both	Initialize	Disconnected	Fail
<input type="checkbox"/>	<input type="checkbox"/>	G10.14	ForceAuthorized	INACTIVE	Authorized	Unauthorized	Port Based	Both	Both	Initialize	Disconnected	Fail
<input type="checkbox"/>	<input type="checkbox"/>	G10.15	ForceAuthorized	INACTIVE	Authorized	Unauthorized	Port Based	Both	Both	Initialize	Disconnected	Fail
<input type="checkbox"/>	<input type="checkbox"/>	G10.16	ForceAuthorized	INACTIVE	Authorized	Authorized	Port Based	Both	Both	ForceAuth	ForceAuth	Fail
<input type="checkbox"/>	<input type="checkbox"/>	Ex0.1	ForceAuthorized	INACTIVE	Authorized	Unauthorized	Port Based	Both	Both	Initialize	Disconnected	Fail
<input type="checkbox"/>	<input type="checkbox"/>	Ex0.2	ForceAuthorized	INACTIVE	Authorized	Unauthorized	Port Based	Both	Both	Initialize	Disconnected	Fail

Clicking the PORT SETTINGS tab brings up the 802.1X PORT SETTINGS page (Figure 7-89), which configures security information at the individual port levels. The parameters for this page are shown in Table 7-64.

Table 7-64. 802.1x Port Settings Page Parameters

Parameter	Description
Port	This parameter specifies the Index of the port for which its fields (such as PORT CONTROL, PORT AUTHORIZATION STATUS, and so on) are configured.
Port Control	This parameter specifies the control values of the Authenticator Port. The control values can be: <ul style="list-style-type: none"> <li>• <b>Force Authorize</b> - All the traffic through this port will be allowed always.</li> <li>• <b>Force Unauthorize</b> - All the traffic through this port will be blocked always.</li> <li>• <b>Auto</b> - The 802.1x authentication process will be imposed over this port.</li> </ul>
Port Authorization Status	This parameter specifies current status of the port either as <i>Authorized</i> or <i>Un-Authorized</i> .
Authentication Mode	This parameter specifies the configuration for selecting the AUTHENTICATION MODE to be <i>Port Based</i> .
Admin Control Direction	This parameter specifies whether security is to be imposed for <ul style="list-style-type: none"> <li>• <b>In</b> - the incoming traffic</li> <li>• <b>Both</b> - both incoming and outgoing traffic</li> </ul>
Operational Control Direction	This parameter specifies the current security status.
Port Initialize	This parameter specifies the initialization control for the port. Setting this value to <i>True</i> causes the port to be initialized. The value reverts to <i>False</i> once initialization is complete.
Maximum Authentication Request	This parameter specifies the maximum number of authentication requests that can be sent from the authenticator before getting a response from the supplicant.
Reauthentication	This parameter provides configuration to enable or disable the reauthentication mechanism on the port.

Timers

Figure 7-90. 802.1x Timer Configuration Page

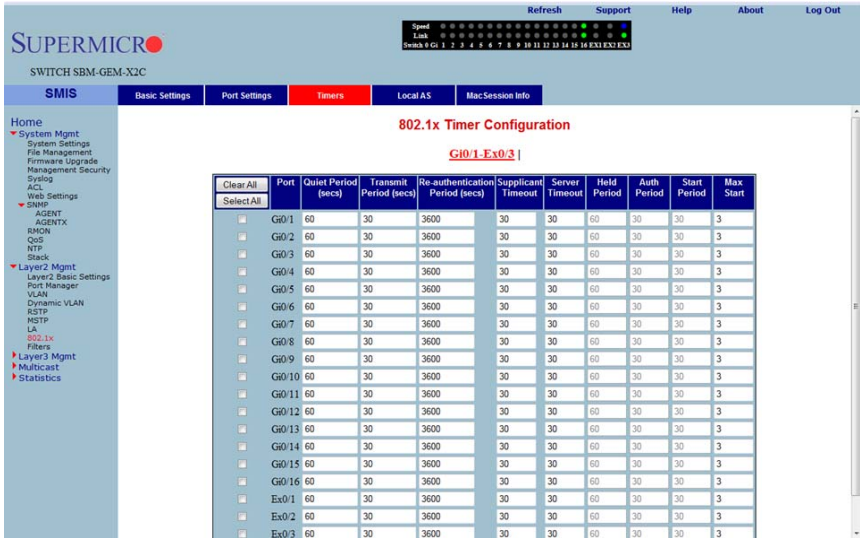

Clicking the TIMERS tab brings up the 802.1x TIMER CONFIGURATION page (Figure 7-90), which configures Timer parameters at the individual port level. The parameters for this page are shown in Table 7-13.

Table 7-65. 802.1x Timer Configuration Page Parameters

Parameter	Description
Port	This parameter is the index of the port for which fields such as QUIET PERIOD, TRANSMIT PERIOD, and such are configured.
Quiet Period (Seconds)	This parameter specifies the duration for which the authenticator will be silent and will not attempt to acquire a supplicant. It can be configured to any value in the range from 1 to 65535 seconds.
Transmit Period (Seconds)	This parameter specifies the time period used by the Authenticator State machine to define when the EAPOL PDU is to be transmitted. It can be configured to any value in the range from 1 to 65535 seconds.
Re-authentication Period (Seconds)	This parameter specifies the time between periodic re-authentication of the supplicant.



## Local AS

Figure 7-91. Local Authentication Server Configuration Page

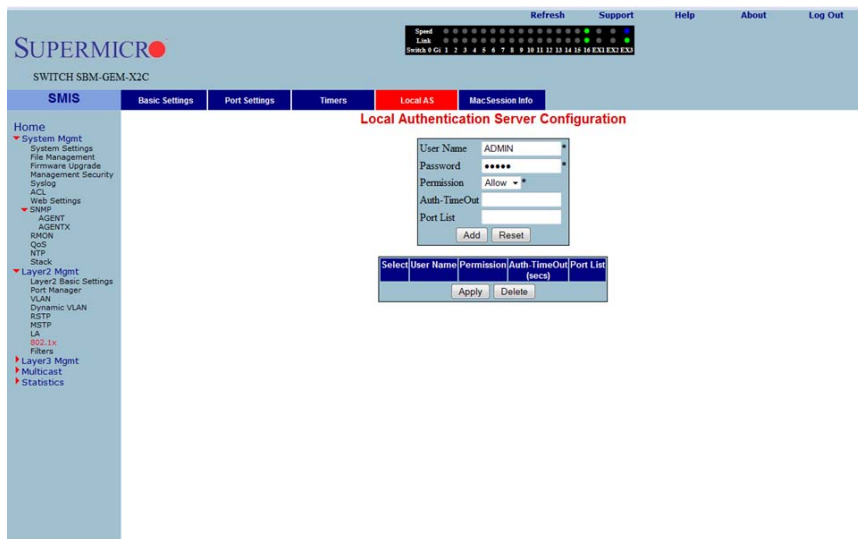

Clicking the LOCAL AS tab brings up the LOCAL AUTHENTICATION SERVER CONFIGURATION page (Figure 7-22), which configures Local Authentication Server information. The parameters for this page are shown in Table 7-13.

Table 7-66. Local Authentication Server Configuration Page Parameters

Parameter	Description
User Name	This parameter specifies the identity of the user who is seeking authentication, and is set by a string of not more than 20 printable characters.
Password	This parameter specifies the password specific to the user name, and is set by a string of not more than 20 printable characters.
Permission	This parameter represents the allowance and denial of access. The values that can be configured are: <ul style="list-style-type: none"> <li><b>Allow</b> - When set to <i>Allow</i>, the authentication request is allowed over the set of ports in the PORT LIST.</li> <li><b>Deny</b> - When set to <i>Deny</i>, the authentication request is NOT allowed over the set of ports in the PORT LIST.</li> </ul>
Port List	This parameter represents the complete set of ports of the authenticator to which the user is allowed or denied access. It is based on permission.

## MAC Session Info

Figure 7-92. MAC Session Info Page

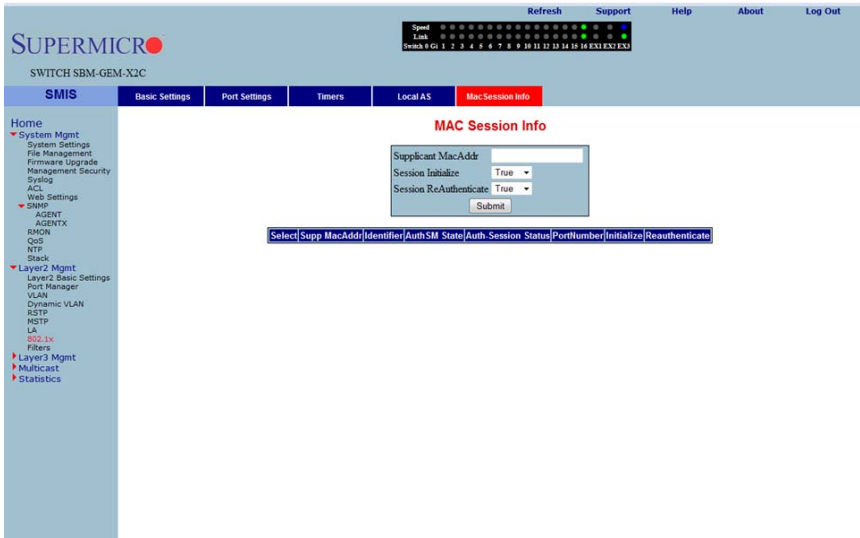

Clicking the MAC SESSION INFO tab brings up the MAC SESSION INFO page (Figure 7-22), which configures the supplicant MAC address. The parameters for this page are shown in Table 7-13.

Table 7-67. MAC Session Info Page Parameters

Parameter	Description
Session Initialize	This parameter is the initialization control for this Supplicant MAC address. Setting this attribute to <i>True</i> causes the Supplicant session with this MAC address, to be initialized. The attribute value reverts to <i>False</i> once initialization has completed.
Session ReAuthenticate	This parameter is the reauthentication control for this Supplicant MAC address. Setting this attribute to <i>True</i> causes the Authenticator PAE state machine for this MAC address to reauthenticate the Supplicant. Setting this attribute to <i>False</i> has no effect. This attribute always returns to <i>False</i> when it is read.

## Filters

The Filters link allows you to configure Layer 2 packet filtering.

The Layer 2 packet filtering management has the following configuration pages:

- "Unicast Filters" on page 7-107
- "Multicast Filters" on page 7-108

### Unicast Filters

Figure 7-93. L2 Unicast Filter Configuration Page

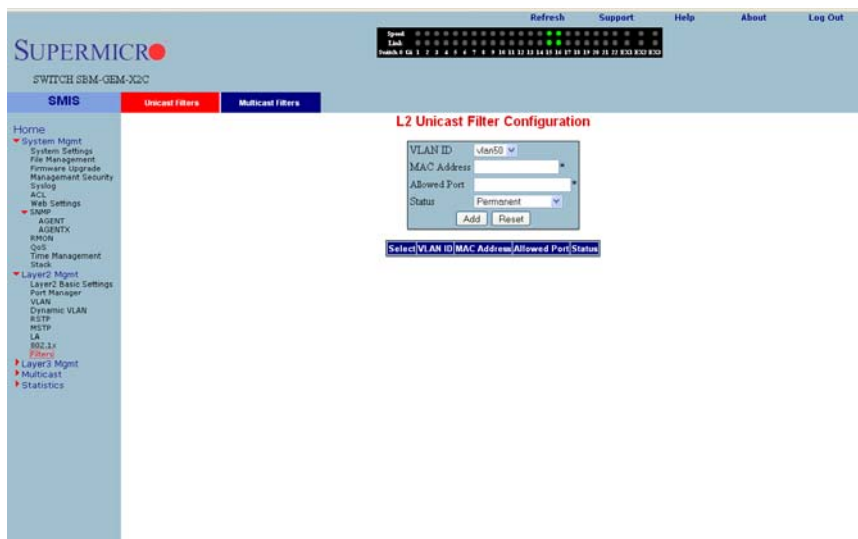

Clicking the UNICAST FILTERS tab brings up the L2 UNICAST FILTER CONFIGURATION page (Figure 7-22), which sets the filter configuration to control the unicast packets that the switch needs to process. The parameters for this page are shown in Table 7-13.

Table 7-68. L2 Unicast Filter Configuration Page Parameters

Parameter	Description
FDB ID	This parameter specifies the forwarding database ID.
MAC Address	This parameter specifies the destination MAC address of the received packet.
Receive Port	This parameter specifies the port on which the packet was received.

**Table 7-68. L2 Unicast Filter Configuration Page Parameters (Continued)**

Parameter	Description
Allowed Ports	This parameter specifies the list of ports on which the received packet, with the above set MAC address (if received from the configured port) can be forwarded.
Status	You can choose to set this configuration to any one of the following types: <ul style="list-style-type: none"> <li>• <b>Other</b> – For entries currently in use, but whose conditions remain different from the following values.</li> <li>• <b>Permanent</b> – Entries that reside even after the restart of the switch.</li> <li>• <b>DeleteOnReset</b> – This deletes the entry on restart.</li> <li>• <b>DeleteOnTimeout</b> – This deletes the entry on expiration of the ageing timer.</li> </ul>

**Multicast Filters**

**Figure 7-94. L2 Multicast Filter Configuration Page**



Clicking the MULTICAST FILTERS tab brings up the L2 MULTICAST FILTER CONFIGURATION page (Figure 7-22), which allows you to set the filter configuration to control the multicast packets that the switch needs to process. The parameters for this page are shown in Table 7-13.

Table 7-69. L2 Multicast Filter Configuration Page Parameters

Parameter	Description
VLAN ID	This parameter specifies the VLAN ID.
MAC Address	This parameter specifies the destination MAC address of the received packet.
Receive Port	This parameter specifies the port on which the packet was received.
Allowed Ports	This parameter specifies the list of ports on which the received packet, with the above set MAC address (if received from the configured port) can be forwarded.
Forbidden Ports	This parameter specifies the list of ports on which the received packet, with the above set MAC address (if received from the configured port) must NOT be forwarded.
Status	You can choose to set this configuration to any one of the following types: <ul style="list-style-type: none"> <li>• <b>Permanent</b> – This configuration resides even after restart of the switch.</li> <li>• <b>DeleteOnReset</b> – This configuration deletes the entry on restart.</li> <li>• <b>DeleteOnTimeout</b> – This configuration deletes the entry on expiration of the ageing timer.</li> </ul>

## 7-6 Layer 3 Management

Figure 7-95. Layer3 Management Page

The screenshot shows the SUPERMICRO web interface for a SWITCH SBM-GEM-X2C. The top navigation bar includes 'Refresh', 'Support', 'Help', 'About', and 'Log Out'. A status bar shows 'Speed Link' and a row of port indicators (S1-S24, E1-E24). The left sidebar menu is expanded to 'Layer3 Mgmt', showing sub-items: IP, IPv6, DHCP, RIP, RIPng, OSPF, OSPFv3, BGP, RRD, RRDv6, VRRP, Multicast, and Statistics. The main content area is titled 'Welcome to the Layer3 Management Page' and contains the text: 'The various layer3 features of the Supermicro Switch can be configured through the links available in this page.' Below this text is a vertical list of icons and links for: IP (configure router and create VLAN), IPv6 (configure ipv6 router), DHCP Server (configure pool of addresses), DHCP Relay (configure DHCP Relay status), RIP (configure RIP feature), RIPng (configure RIPng feature), OSPF (configure OSPF status), OSPFv3 (configure OSPFv6 features), BGP (configure neighbour list), and BRD.

The LAYER 3 MANAGEMENT home page (Figure 7-95) has links to all Layer 3 features.

## IP

The IP link enables you to perform IP related configuration. This can be done through the following pages.

- "Vlan Interface" on page 7-110
- "IP V4 Interface Settings" on page 7-111
- "IP Route" on page 7-112
- "LoopBack Basic Settings" on page 7-113

### Vlan Interface

Figure 7-96. VLAN Interface Basic Settings Page

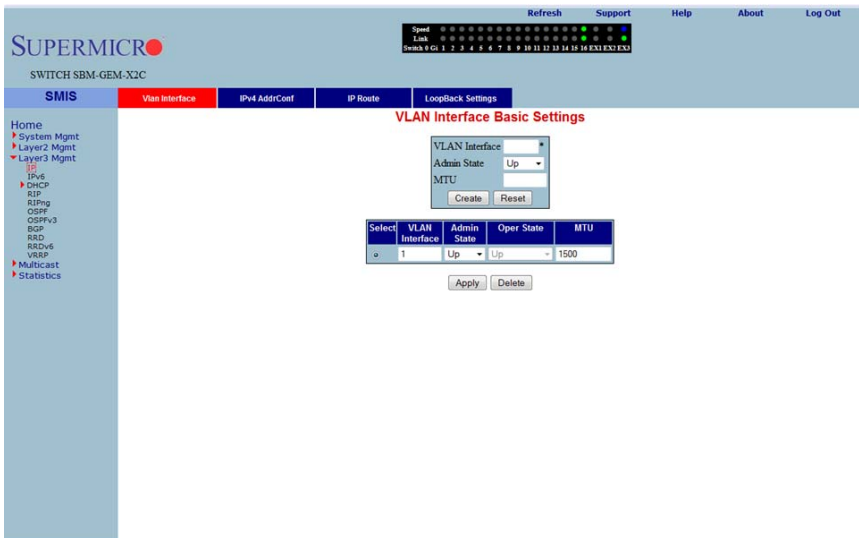

Clicking the VLAN INTERFACE tab brings up the VLAN INTERFACE BASIC SETTINGS page (Figure 7-96), which allows configuring of L3 VLAN interfaces. The parameters for this page are shown in Table 7-70.

Table 7-70. VLAN Interface Basic Settings Page Parameters

Parameter	Description
VLAN Interface	This parameter specifies the VLAN identifier.
Admin State	This parameter specifies the admin state as either <i>Up</i> or <i>Down</i> .
MTU	This parameter specifies the maximum transfer unit size in bytes.

## IP V4 Interface Settings

Figure 7-97. IPv4 Interface Settings Page

The screenshot displays the IPv4 Interface Settings page. At the top, there are navigation links: Refresh, Support, Help, About, and Log Out. Below these is a status bar with 'Speed' and 'Link' indicators. The main navigation menu includes SMIS, Vlan Interface, IPv4 AddrConf (highlighted), IP Route, and LoopBack Settings. The left sidebar shows a tree view of management options: Home, System Mgmt, Layer2 Mgmt, Layer3 Mgmt, IP, DHCP, RIP, RIPv2, OSPF, OSPFv3, BGP, RRD, RSDv6, VRRP, Multicast, and Statistics. The main content area is titled 'IPv4 Interface Settings' and contains a form with the following fields: Interface VLAN Id (vlan1), IP Address, Subnet Mask, and Address Type (Primary). There are 'Add' and 'Reset' buttons below the form. Below the form is a table with the following data:

Select	Interface	IP Address	Subnet Mask	Broadcast Address	Address Type
<input type="radio"/>	mgmt	10.0.0.1	255.0.0.0	10.255.255.255	Primary
<input type="radio"/>	vlan1	192.168.100.1	255.255.255.0	192.168.100.255	Primary

At the bottom of the table are 'Apply' and 'Delete' buttons.

Clicking the IPV4 ADDR CONF tab brings up the IPV4 INTERFACE SETTINGS page (Figure 7-97), which allows you to configure the IP address for L3 VLANs. The parameters for this page are shown in Table 7-71.

Table 7-71. IPv4 Interface Settings Page Parameters

Parameter	Description
Interface VLAN ID	This parameter specifies the VLAN interface.
IP Address	This parameter specifies the IP Address of the specified interface.
Subnet Mask	This parameter indicates the mask for the specified IP Address.
Address Type	This parameter specifies the type of address, which can be <i>Primary</i> or <i>Secondary</i> .

IP Route

Figure 7-98. IP Route Configuration Page

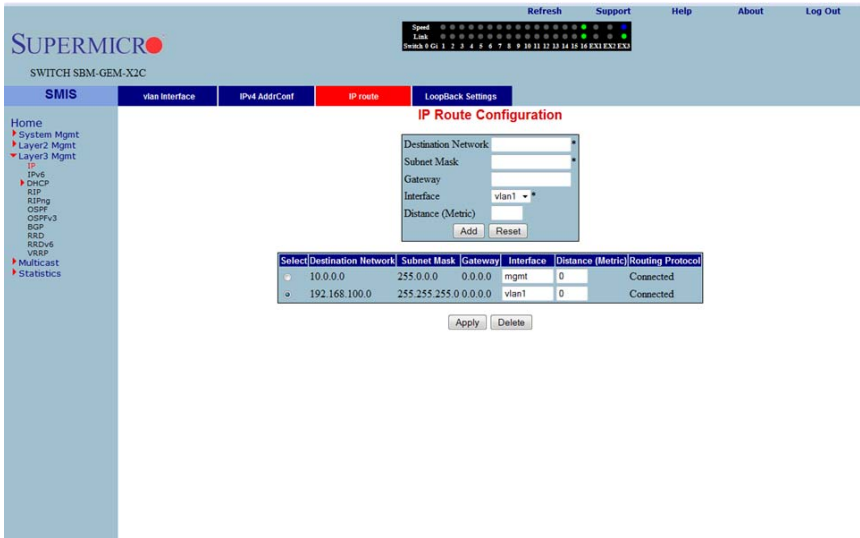

Clicking the IP ROUTE tab brings up the IP ROUTE CONFIGURATION page (Figure 7-98), which allows you to configure the static IP routes. The parameters for this page are shown in Table 7-72.

Table 7-72. IP Route Configuration Page Parameters

Parameter	Description
Destination Network	This parameter specifies the IP address for which the route is being added.
Subnet Mask	This parameter indicates the subnet mask for the Destination Network address.
Gateway	This parameter denotes the Next Hop Gateway to reach the IP address.
Interface	This parameter specifies the outgoing interface.
Distance (Metric)	This parameter specifies the metric value of the destination.



## LoopBack Basic Settings

Figure 7-99. LoopBack Basic Settings Page

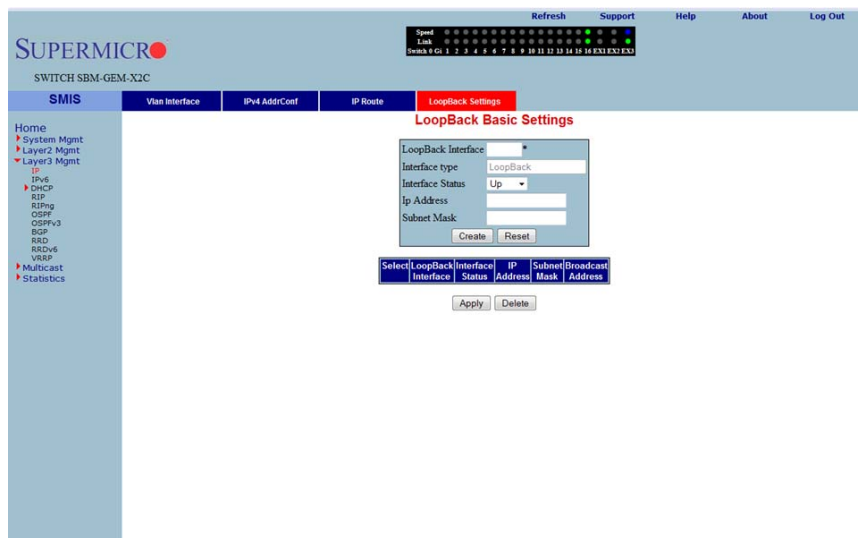

Clicking the LOOPBACK SETTINGS tab brings up the LOOPBACK BASIC SETTINGS page (Figure 7-99), which allows you to configure loopback IP interfaces. The parameters for this page are shown in Table 7-73.

Table 7-73. LoopBack Basic Settings Page Parameters

Parameter	Description
LoopBack Interface	This parameter is the name of the loopback interface getting created.
Interface Type	This parameter is always the loopback for this configuration.
Interface Status	This parameter for the INTERFACE STATUS can be set to <i>Up</i> or <i>Down</i> .
IP Address	This parameter specifies the IP address for this loopback interface.
Subnet Mask	This parameter specifies the subnet mask for this loopback interface.

## IP V6

The IPv6 link allows you to perform IPv6 related configurations. This can be accomplished through the following six pages.

- "IPv6 Route Configuration" on page 7-114
- "IPv6 Interface" on page 7-115
- "ND Cache" on page 7-116
- "Address Settings" on page 7-117
- "Address Profile" on page 7-118
- "Prefix Settings" on page 7-119

### IPv6 Route Configuration

Figure 7-100. IPv6 Route Configuration Page

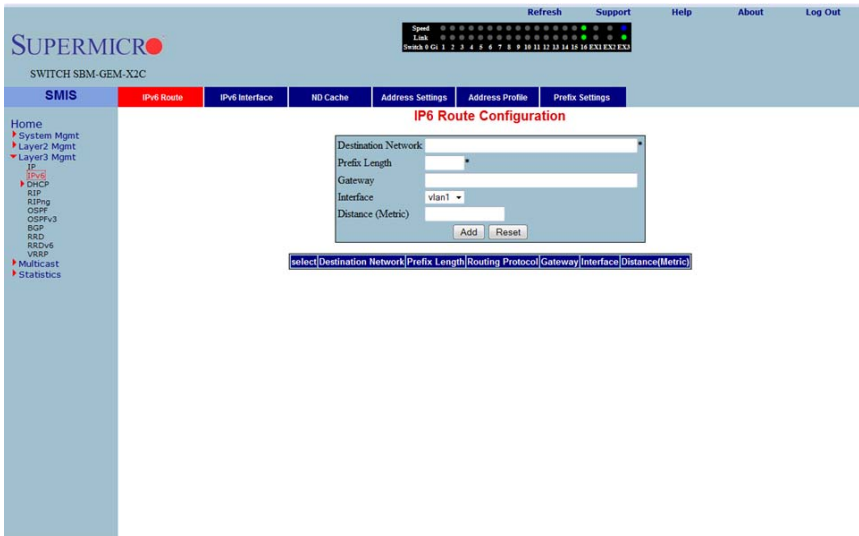

Clicking the IPv6 ROUTE tab brings up the IPv6 ROUTE CONFIGURATION page (Figure 7-100), which configures various IP6 Route parameters. The parameters for this page are shown in Table 7-74.

Table 7-74. IPv6 Route Configuration Page Parameters

Parameter	Description
Destination Network	This parameter specifies the network address for which the IPv6 route is being added.
Prefix Length	This parameter specifies the subnet mask for the above said address.

Table 7-74. IPv6 Route Configuration Page Parameters (Continued)

Parameter	Description
Routing Protocol	This parameter indicates the routing protocol through which the route was learnt, if not manual. This cannot be configured.
Gateway	This parameter specifies the Next Hop Gateway to reach the IP address.
Interface	This parameter indicates the outgoing interface.
Distance (Metric)	This parameter denotes metric value of the destination.

## IPv6 Interface

Figure 7-101. IPv6 Interface Settings Page

The screenshot shows the IPv6 Interface Settings page. At the top, there are navigation links: Refresh, Support, Help, About, and Log Out. Below that is a status bar with 'Speed' and 'Link' indicators. The main navigation bar includes 'SMIS' and several tabs: IPv6 Route, IPv6 Interface (selected), ND Cache, Address Settings, Address Profile, and Prefix Settings. The title 'IPv6 Interface Settings' is centered. On the left, a sidebar menu lists various management options like System Mgmt, Layer2 Mgmt, Layer3 Mgmt, IP, IPv6, DHCP, RIP, RIPv6, OSPF, OSPFv3, BGP, RRD, RRDv6, VRRP, Multicast, and Statistics. The main content area features a table with the following data:

Select	Port	Admin	Oper	RA Status	Hop Limit	Def Rtr Time	RA Rch Time	RA Retrans Time	Prefix Adv Status	RA Min	RA Max	DAD Retries
o	vlan1	down	down	Disabled	64	1800	30	1	Enabled	198	600	1

An 'Apply' button is located below the table.

Clicking the IPv6 INTERFACE tab brings up the IPv6 INTERFACE SETTINGS page (Figure 7-101), which displays the various parameters for the IPv6 Interface. The parameters for this page are shown in Table 7-75.

Table 7-75. IPv6 Interface Settings Page Parameters

Parameter	Description
Port	This parameter specifies the Index of the VLAN interface.
Admin	This parameter indicates the Administrative Status of IPv6 on the Interface.
Oper	This parameter specifies the Operational Status of IPv6 on the given Interface, which is a read-only field.
RA Status	This parameter indicates the Router Advertisement status on the Interface.

**Table 7-75. IPv6 Interface Settings Page Parameters (Continued)**

Parameter	Description
Hop Limit	This parameter denotes the Hop Limit value to be placed in the Router Advertisements sent on the Interface.
Def-Rtr Time	This parameter specifies the Default router lifetime to be placed in the Router Advertisements sent on the interface.
RA Rch Time	This parameter indicates the Reachable time to be placed in the Router Advertisements sent on the interface.
RA Retrans Time	This parameter specifies the RA Retransmit time to be placed in the Router Advertisement sent on the interface.
Prefix-Adv Status	This parameter specifies the Prefix Advertisement status on the Interface.
RA Min	This parameter specifies the minimum time in seconds allowed between sending unsolicited router advertisements.
RA Max	This parameter indicates the maximum time in seconds allowed between sending unsolicited router advertisements.
DAD Retries	This parameter specifies the maximum number of Duplicate Address Detection retries.

**ND Cache**

**Figure 7-102. ND Cache Configuration Page**

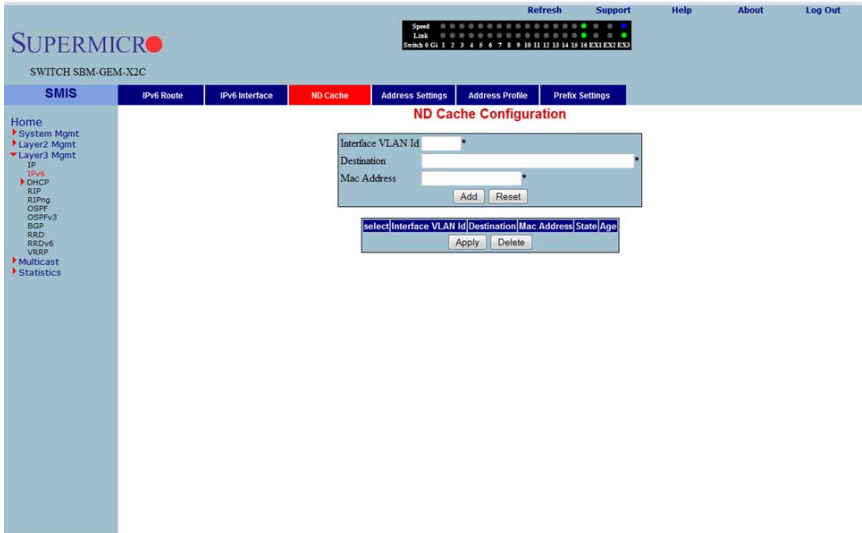

Clicking the ND CACHE tab brings up the ND CACHE CONFIGURATION page (Figure 7-102). The parameters for this page are shown in Table 7-76.

Table 7-76. ND Cache Configuration Page Parameters

Parameter	Description
Interface VLAN ID	This parameter indicates index of the VLAN interface.
Destination	This parameter specifies Destination IPv6 address.
MAC Address	This parameter denotes the physical address of the Destination address.
State	This parameter indicates the Reachability state of the entry, which is a read-only field.
Age	This parameter specifies the Age Time.

## Address Settings

Figure 7-103. Address Settings Page

The screenshot displays the SUPERMICR web interface for a SWITCH SBM-GEM.X2C. The 'Address Settings' tab is active, showing a configuration form for an IPv6 address. The form includes the following fields and controls:

- Interface VLAN Id: dropdown menu showing 'vlan1'
- Address: text input field
- Prefix Length: dropdown menu
- Address Type: dropdown menu showing 'Unicast'
- Address Profile ID: dropdown menu
- Buttons: 'Add' and 'Reset'

Below the form, a URL bar indicates the selected parameters: `select[Interface VLAN Id][Address][Prefix Length][Address Type][Address Profile ID]`.

Clicking the ADDRESS SETTINGS tab brings up the ADDRESS SETTINGS page (Figure 7-103), which allows you to configure address settings for IPv6. The parameters for this page are shown in Table 7-77.

Table 7-77. Address Settings Page Parameters

Parameter	Description
Interface VLAN ID	This parameter specifies the index of the VLAN Interface.
Address	This parameter specifies the IPv6 address.

**Table 7-77. Address Settings Page Parameters (Continued)**

Parameter	Description
Prefix Length	This parameter indicates the length of the prefix (in bits) associated with this entry's IPv6 address.
Address Type	This parameter specifies that the type of address can be <i>Link-Local</i> , <i>Global-Unicast</i> or <i>Anycast</i> .
Address Profile ID	This parameter indicates the index to the IPv6 address Profile table.

**Address Profile**

**Figure 7-104. Address Profile Settings Page**

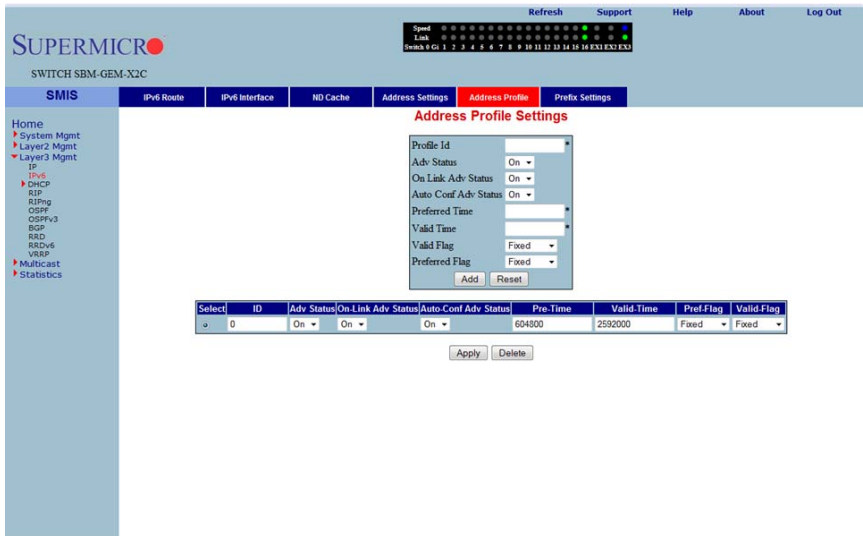

Clicking the ADDRESS PROFILE tab brings up the ADDRESS PROFILE SETTINGS page (Figure 7-104). The parameters for this page are shown in Table 7-78.

**Table 7-78. Address Profile Settings Page Parameters**

Parameter	Description
Profile ID	This parameter specifies the index of the Address Profile entry.
Adv Status	This parameter specifies the Prefix Advertise status.
On Link Adv Status	This parameter indicates the On-Link Advertise Flag status.
Auto Conf Adv Status	This parameter denotes the Autonomous Configuration Advertise Flag status.

Table 7-78. Address Profile Settings Page Parameters (Continued)

Parameter	Description
Preferred Time	This parameter specifies the Preferred Lifetime of the prefix address that uses this profile.
Valid Time	This parameter indicates the Valid Lifetime of the prefix address that uses this profile.
Valid Flag	This parameter specifies if the Valid Lifetime Flag is <i>Variable</i> or <i>Fixed</i> .
Preferred Flag	This parameter specifies if the Preferred Lifetime Flag is <i>Variable</i> or <i>Fixed</i> .

## Prefix Settings

Figure 7-105. Prefix Configuration Page

The screenshot displays the SUPERMICR SWITCH SBM-GEM-X2C web interface. At the top, there is a status bar with 'Speed' (indicated by a progress bar), 'Refresh', 'Support', 'Help', 'About', and 'Log Out' links. Below this is a navigation menu with tabs for 'IPv6 Route', 'IPv6 Interface', 'ND Cache', 'Address Settings', 'Address Profile', and 'Prefix Settings' (which is highlighted in red). On the left side, there is a vertical navigation menu with options like 'Home', 'System Mgmt', 'Layer2 Mgmt', 'Layer3 Mgmt', 'IP', 'IPv6', 'DHCP', 'RIP', 'RIPng', 'OSPF', 'OSPFv3', 'BGP', 'RSD', 'RSDv6', 'VSRP', 'Multicast', and 'Statistics'. The main content area is titled 'Prefix Configuration' and contains a form with the following fields: 'Interface VLAN ID', 'Prefix', 'Prefix Length', and 'Prefix Profile ID'. Below the form are 'Add' and 'Reset' buttons. Underneath the form is a table with one row containing the values 'Interface VLAN ID', 'Prefix', 'Prefix Length', and 'Prefix Profile ID', with a 'Delete' button to its right.

Clicking the PREFIX SETTINGS tab brings up the PREFIX CONFIGURATION page (Figure 7-105). The parameters for this page are shown in Table 7-79.

Table 7-79. Prefix Configuration Page Parameters

Parameter	Description
Interface VLAN ID	This parameter specifies the index of the VLAN Interface.
Prefix	This parameter indicates the IPv6 address prefix to be advertised in RA.
Prefix Length	This parameter indicates the PREFIX LENGTH (in bits).
Prefix Profile ID	This parameter specifies index to the IPv6 address profile table.

## DHCP Server

The DHCP Server link helps you to manage the DHCP server in the switch through the following two pages:

- "DHCP Basic Settings" on page 7-120
- "Pool Settings" on page 7-121

### DHCP Basic Settings

Figure 7-106. DHCP Basic Settings Page

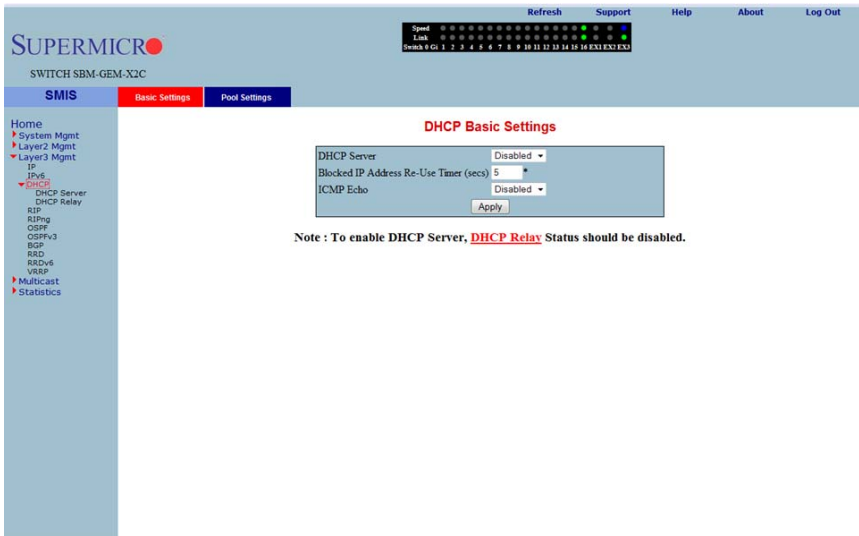

Clicking the DHCP SETTINGS tab brings up the DHCP BASIC SETTINGS page (Figure 7-106). The parameters for this page are shown in Table 7-80.

Table 7-80. DHCP Basic Settings Page Parameters

Parameter	Description
DHCP-Server	With this parameter you can enable or disable the DHCP server using this configuration.
Offer-reuse Time out (seconds)	This parameter specifies the Reuse Timeout value that can be configured in this field, which is used by DHCP.
ICMP Echo	This parameter enables or disables the ICMP Echo feature.



## Pool Settings

Figure 7-107. DHCP Pool Settings Page

The screenshot shows the DHCP Pool Settings page in the SUPERMICR switch management interface. The page has a navigation menu on the left with 'Pool Settings' selected. The main content area is titled 'DHCP Pool Settings' and contains a form with the following fields:

- Pool ID
- Subnet Pool
- Network Mask
- Start IP Address
- End IP Address
- Lease Time (Secs)
- Utilization Threshold

Below the form are 'Add' and 'Reset' buttons. At the bottom of the page, there is a table with the following columns: Pool ID, Subnet Pool, Network Mask, Start IP Address, End IP Address, Lease Time (secs), Threshold, and Status. Below the table are 'Apply' and 'Delete' buttons.

Clicking the POOL SETTINGS link brings up the DHCP POOL SETTINGS page (Figure 7-107), which allows you to configure the IP address pool that can be used by the DHCP server to allocate IP addresses. The parameters for this page are shown in Table 7-81.

Table 7-81. DHCP Pool Settings Page Parameters

Parameter	Description
Pool ID	This parameter specifies the pool ID to index among the different subnet pools configured.
Network	This parameter specifies the subnet of the IP address in the pool.
Subnet Mask	This parameter specifies the subnet mask of the IP address in the pool.
Start IP	This parameter specifies the first IP address in the address pool that is used for dynamic allocation by the DHCP server.
End IP	This parameter specifies the last IP address in the address pool that is used for dynamic allocation by the DHCP server.
Lease Time	This parameter specifies the time interval for which the IP address is valid.
Utilization Threshold	This parameter specifies the DHCP Pool Utilization Threshold value.
Status	This parameter specifies the status of the entry.

## DHCP Relay

The DHCP Relay link helps you to manage the DHCP relay in the switch through the following two pages:

- "DHCP Relay Basic Settings" on page 7-122
- "Interface Settings" on page 7-123

### DHCP Relay Basic Settings

Figure 7-108. DHCP Relay Configuration Page

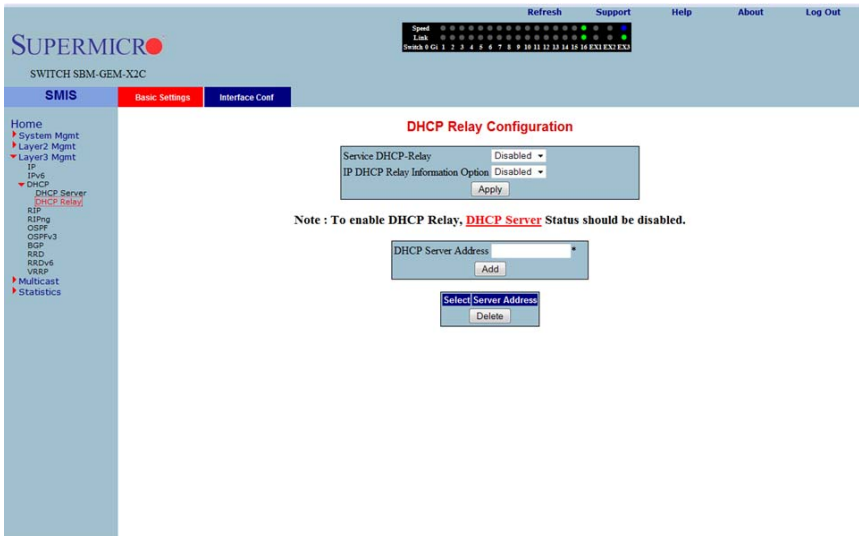

Clicking the BASIC SETTINGS tab brings up the DHCP RELAY CONFIGURATION page (Figure 7-108), which displays the various parameters for configuring the DHCP relay. The parameters for this page are shown in Table 7-82.

Table 7-82. DHCP Relay Configuration Page Parameters

Parameter	Description
Service DHCP-Relay	This parameter specifies the DHCP relay status that can be enabled or disabled in the switch using this field.
IP DHCP Relay Information Option	You can enable/disable this field to control the processing related to the Relay Agent Information options.
DHCP Server Address	This parameter indicates the IP address of the DHCP Server to which the Relay Agent needs to forward the packets from the client.

## Interface Settings

Figure 7-109. DHCP Relay Interface Configuration Page

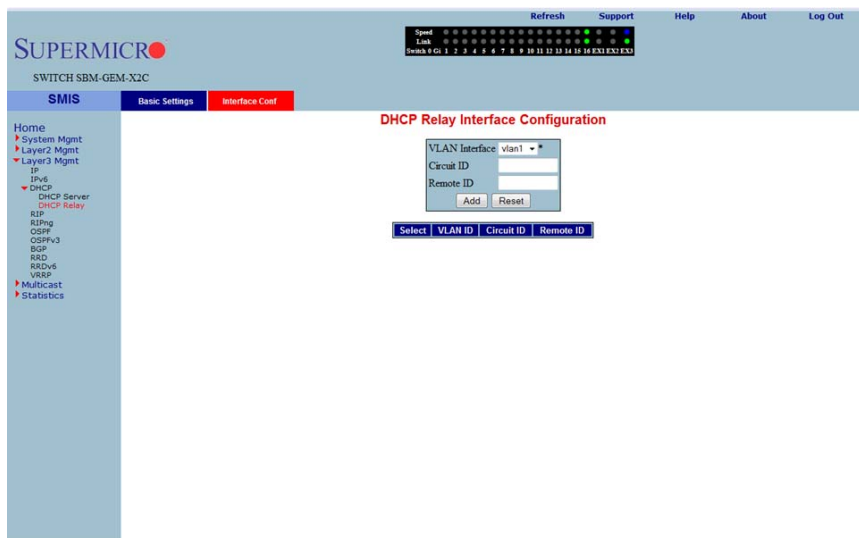

Clicking the INTERFACE CONF tab brings up the DHCP RELAY INTERFACE CONFIGURATION page (Figure 7-109), which allows you to configure the DHCP relay for VLANs. The parameters for this page are shown in Table 7-83.

Table 7-83. DHCP Relay Interface Configuration Page Parameters

Parameter	Description
VLAN Interface	This parameter specifies the VLAN Interface name.
Circuit ID	This parameter specifies the DHCP Relay Circuit identifier.
Remote ID	This parameter specifies the Remote identifier.

## RIP

The RIP link opens the following links for configuration of RIP protocol:

- "RIP Basic Settings" on page 7-124
- "Interfaces" on page 7-125
- "Neighbors List" on page 7-126
- "Security Settings" on page 7-127
- "Address Summarization" on page 7-128

### RIP Basic Settings

Figure 7-110. RIP Basic Settings Page

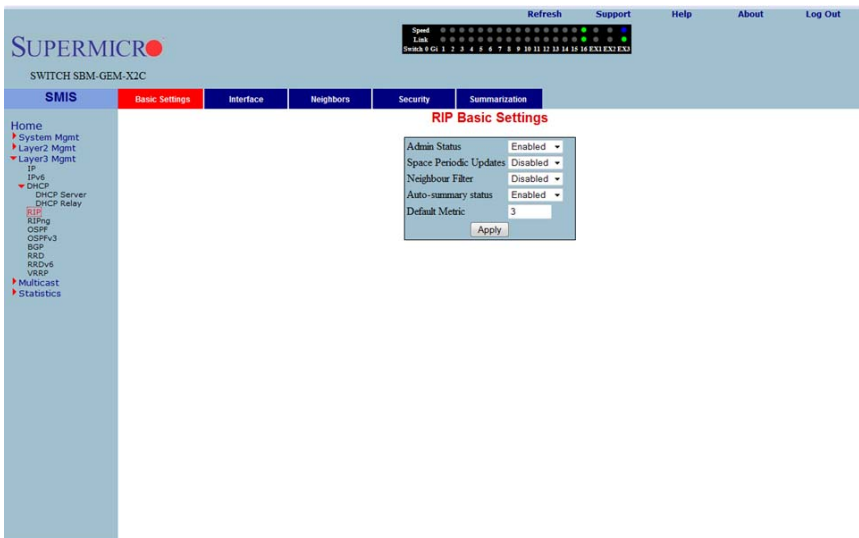

Clicking the BASIC SETTINGS tab brings up the RIP BASIC SETTINGS page (Figure 7-110). The parameters for this page are shown in Table 7-84.

Table 7-84. RIP Basic Settings Page Parameters

Parameter	Description
Output-delay	This parameter specifies the delay that needs to be enabled for RIP to split the periodic update packets before they are sent out.
Neighbor Filter	This parameter enables or disables neighbor filtering. Neighbor filtering helps you to filter routes from specific neighbors.
Auto-summary status	This parameter enables or disables the Auto-summary feature.

## Interfaces

Figure 7-111. RIP Interface Page

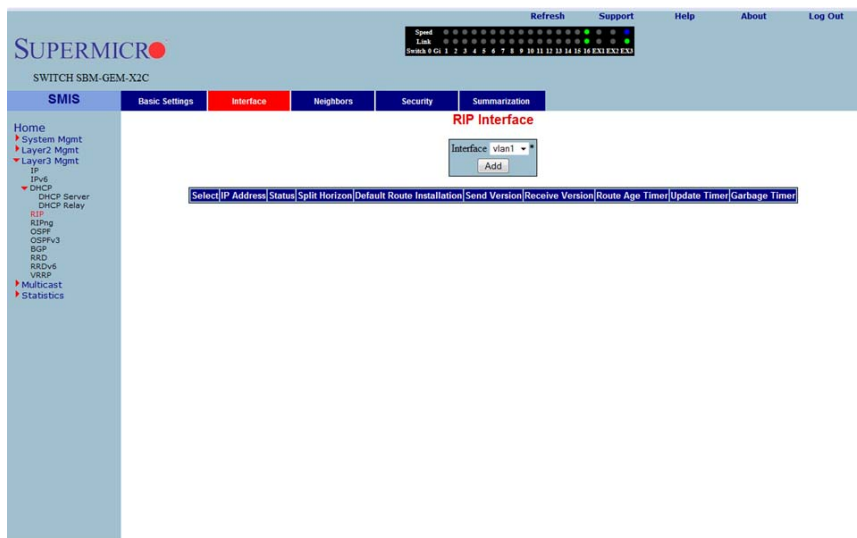

Clicking the INTERFACE tab brings up the RIP INTERFACE page (Figure 7-111). The parameters for this page are shown in Table 7-85.

Table 7-85. RIP Interface Page Parameters

Parameter	Description
Interface	This parameter specifies the Interface ID for which RIP needs to be configured.
IP Address	This parameter specifies the IP address of the RIP interface.
Status	This parameter specifies the admin status of the interface.
Split Horizon	This parameter specifies the operational status of Split Horizon in the system.
Default Route Installation	This parameter specifies whether Default Route Installation can be done or not.
Send Version	This parameter allows selecting the RIP packets sent to be compatible to either <i>RIPV1</i> , <i>RIP1 Compatible</i> or <i>RIPV2</i> .
Receive Version	This parameter is similar to SEND VERSION, but it allows you to choose the RIP packets to be received as either <i>RIPV1</i> , <i>RIPV2</i> , both <i>RIPv1 and RIPv2</i> or <i>None</i> .
Route Age Timer	This parameter specifies the time interval after which the routes will be flushed.

**Table 7-85. RIP Interface Page Parameters (Continued)**

Parameter	Description
Update Timer	This parameter specifies the time interval between successive RIP updates.
Garbage Timer	This parameter specifies the time interval after which the invalid routes will be removed from the routing table.

### Neighbors List

**Figure 7-112. RIP Neighbor List Page**

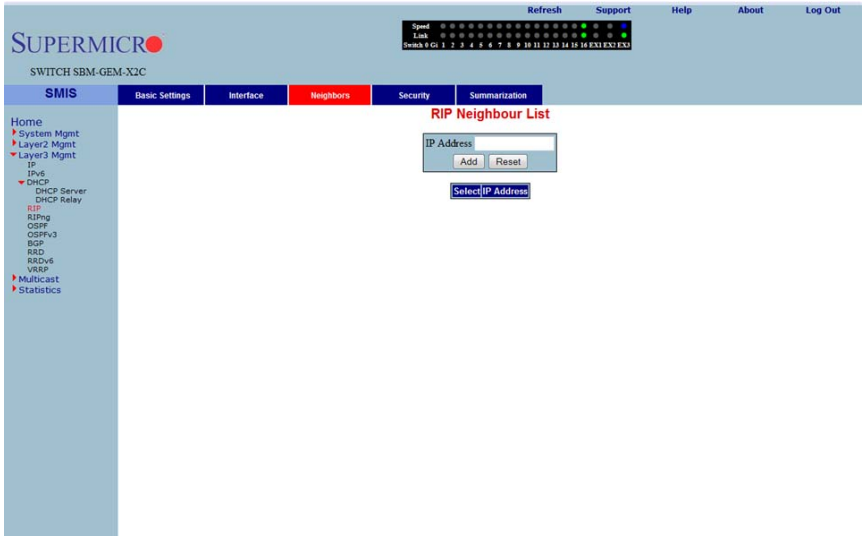

Clicking the NEIGHBORS tab brings up the RIP NEIGHBOR LIST page (Figure 7-112), which is used to configure the RIP neighbors, by configuring their IP address.

The single parameter for this page is IP ADDRESS, which specifies the IP Address of the neighbor router to which the unicast update has to be sent.

## Security Settings

Figure 7-113. RIP Security Settings Page

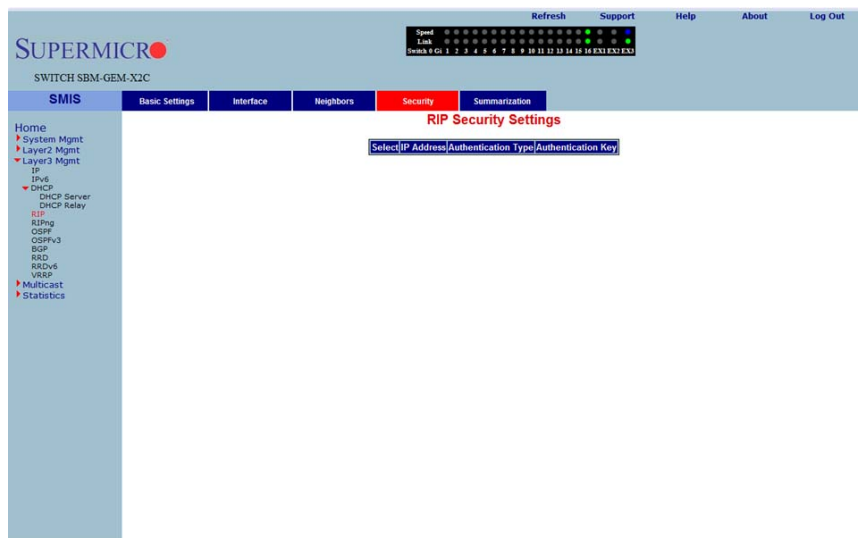

Clicking the SECURITY tab brings up the RIP SECURITY SETTING page (Figure 7-113). The parameters for this page are shown in Table 7-13.

Table 7-86. RIP Security Setting Page Parameters

Parameter	Description
IP Address	This parameter displays the active RIP interfaces. You can select the interface for which you want to configure authentication.
Authentication Type	This parameter specifies the authentication type. You can choose <i>No Authentication</i> , or <i>Simple Password</i> , or the <i>md5</i> authentication type.
Authentication Key	This parameter specifies the key used for authentication if the authentication type is other than <i>No Authentication</i> .

## Address Summarization

Figure 7-114. RIP Interface Specific Address Summarization Page

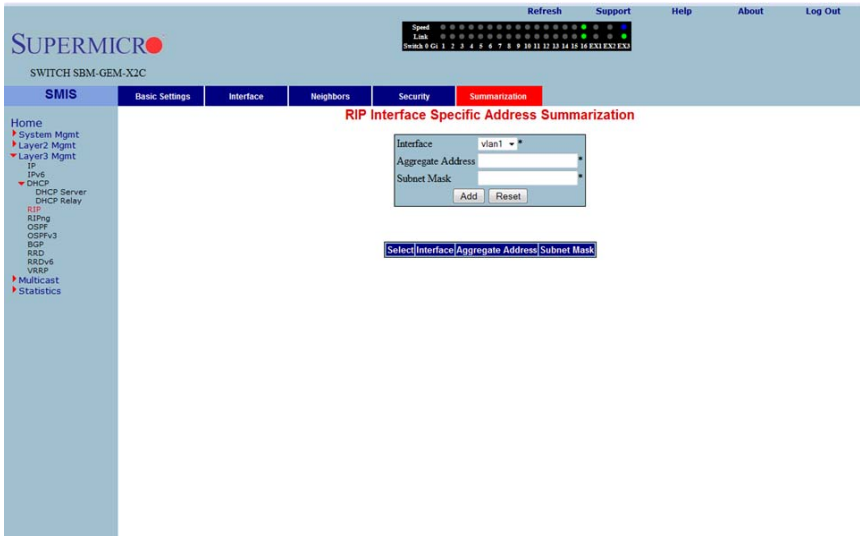

Clicking the SUMMARIZATION tab brings up the RIP INTERFACE SPECIFIC ADDRESS SUMMARIZATION page (Figure 7-114). The parameters for this page are shown in Table 7-87.

Table 7-87. RIP Interface Specific Address Summarization Page Parameters

Parameter	Description
Interface	This parameter specifies the Interface ID for which the RIP aggregate address needs to be configured.
Aggregate Address	This parameter specifies the aggregate address.
Subnet Mask	This parameter specifies the mask of the aggregate address.



## RIPng

The RIP6 link allows you perform RIPv6 related configuration for the switch. This can be accomplished through the following two pages:

- "RIP6 Interface" on page 7-129
- "Filters" on page 7-130

### RIP6 Interface

Figure 7-115. RIP6 Interface Configuration Page

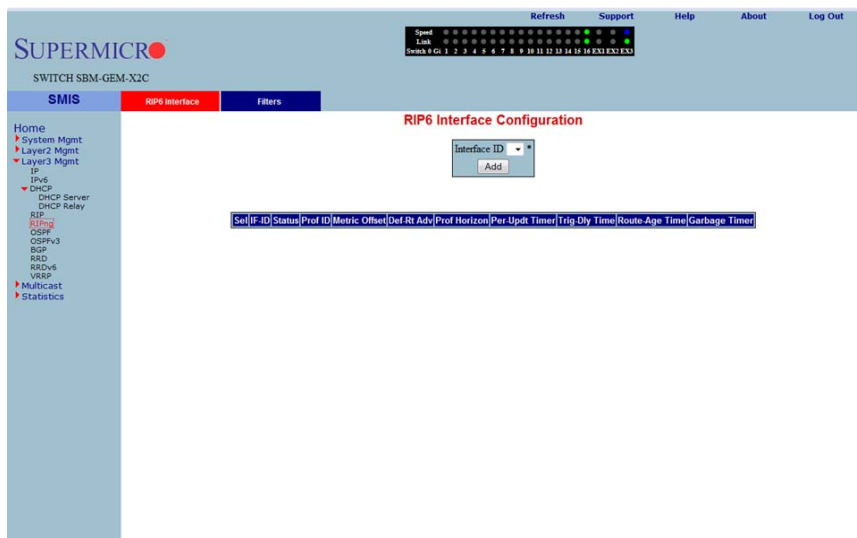

Clicking the RIP6 INTERFACE tab brings up the RIP6 INTERFACE CONFIGURATION page (Figure 7-115). The parameters for this page are shown in Table 7-88.

Table 7-88. RIP6 Interface Configuration Page Parameters

Parameter	Description
Interface ID	Specifies the Interface Id for which RIPv6 needs to be configured.
Status	This parameter specifies the administration status of the interface.
Prof ID	This parameter indicates the Index of the Address Profile entry.
Metric Offset	This parameter specifies the metric for the routes that are being re-distributed.
Def Rt Adv	This parameter indicates the default router lifetime to be placed in the Router Advertisements sent on the interface.

**Table 7-88. RIP6 Interface Configuration Page Parameters (Continued)**

Parameter	Description
Prof Horizon	This parameter specifies the operational status of Profile Horizon in the system.
Per-Updt Timer	This parameter specifies the time interval between successive RIP6 updates.
Trig-Dly Time	This parameter indicates the time interval in seconds by which further triggered updates are delayed, after one triggered update is sent.
Route Age Time	This parameter specifies the time interval after which, the routes are flushed.
Garbage Timer	This parameter specifies the time interval after which, the invalid routes are removed from the routing table.

**Filters**

**Figure 7-116. RIP6 Filter Configuration Page**

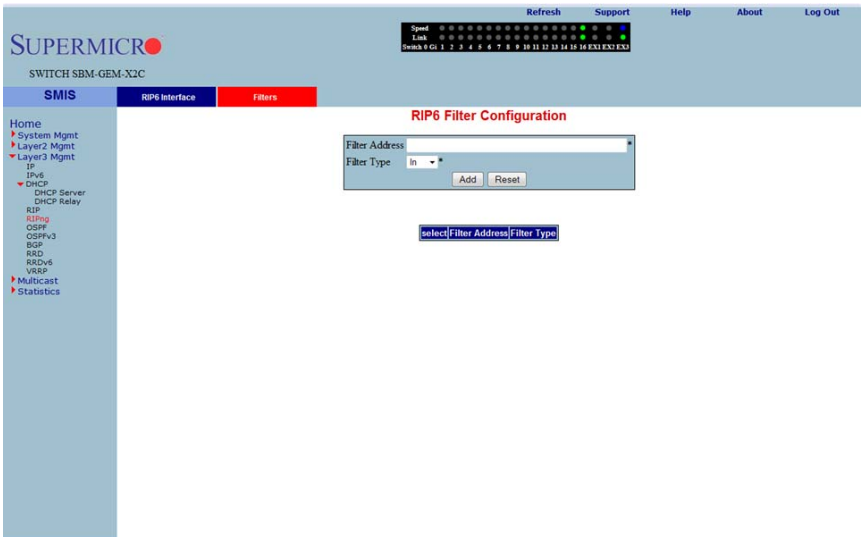

Clicking the FILTERS tab brings up the RIP6 FILTER CONFIGURATION page (Figure 7-116). The parameters for this page are shown in Table 7-89.

**Table 7-89. RIP6 Filter Configuration Page Parameters**

Parameter	Description
Filter Address	This parameter specifies the FILTER ADDRESS for the RIP6 interface.
Filter Type	This parameter specifies the FILTER TYPE for which RIP6 needs to be configured.

## OSPF

The OSPF link allows you to configure the OSPF protocol through the following pages:

- "OSPF Basic Settings" on page 7-132
- "Area" on page 7-133
- "Interface" on page 7-134
- "Virtual Interface" on page 7-135
- "OSPF Neighbor" on page 7-136
- "OSPF RRD Route Configuration" on page 7-137
- "OSPF Area Aggregation" on page 7-138
- "External Aggregation" on page 7-139

### OSPF Basic Settings

Figure 7-117. OSPF Basic Settings Page

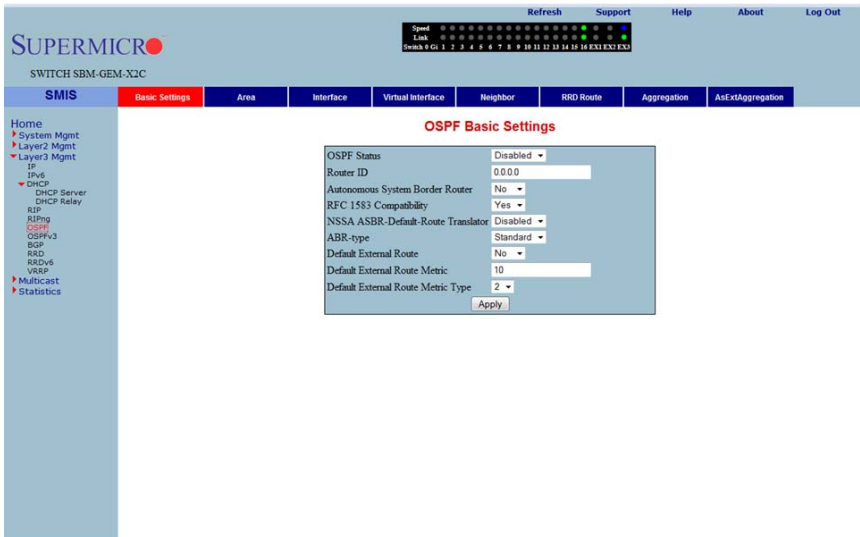

Clicking the BASIC SETTINGS tab brings up the OSPF BASIC SETTINGS page (Figure 7-117). The parameters for this page are shown in Table 7-90.

Table 7-90. OSPF Basic Settings Page Parameters

Parameter	Description
OSPF Status	This parameter specifies the global status of the protocol in the switch.
Router ID	This parameter specifies the router identifier.

Table 7-90. OSPF Basic Settings Page Parameters (Continued)

Parameter	Description
Autonomous System Border Router	This parameter indicates the flag to denote whether or not the router is to be configured as an Autonomous System Border Router.
RFC 1583 Compatibility	This parameter specifies the compatibility to RFC 1583 for choosing the route among multiple AS for the same destination.
External Link State Database Limit	This parameter specifies the maximum number of non-default AS-external-LSA entries that can be stored in the link state database.

## Area

Figure 7-118. OSPF Area Configuration Page

The screenshot shows the OSPF Area Configuration page. The main configuration form includes the following fields:

- Area ID: 0.0.0
- Type: Normal
- Send Summary Routes: Yes
- Stub Metric: 10
- Stub Metric Type: ospfMetric
- TOS: 0
- Translator Role: candidate
- Stability Interval: 40

Below the form is a table summarizing the configuration:

Select	Area ID	Type	Send Summary Routes	Stub Metric	Stub Metric Type	TOS	Translator Role	Stability Interval
<input type="checkbox"/>	0.0.0	Normal	Yes	10	ospfMetric	0	candidate	40

Clicking the AREA tab brings up the OSPF AREA CONFIGURATION page (Figure 7-118). The parameters for this page are shown in Table 7-91.

Table 7-91. OSPF Area Configuration Page Parameters

Parameter	Description
Area ID	This parameter specifies the identifier for the area.
Type	This parameter allows you to configure the area type, as a <i>Stub</i> area, a <i>Normal</i> area or <i>NSSA</i> .
Send Summary Router	This field is used to control the import of summary LSAs to stub areas. This does not have any impact for other areas.
Default Cost	This parameter specifies the metric/cost associated with the routes.

Interface

Figure 7-119. OSPF Interface Configuration Page

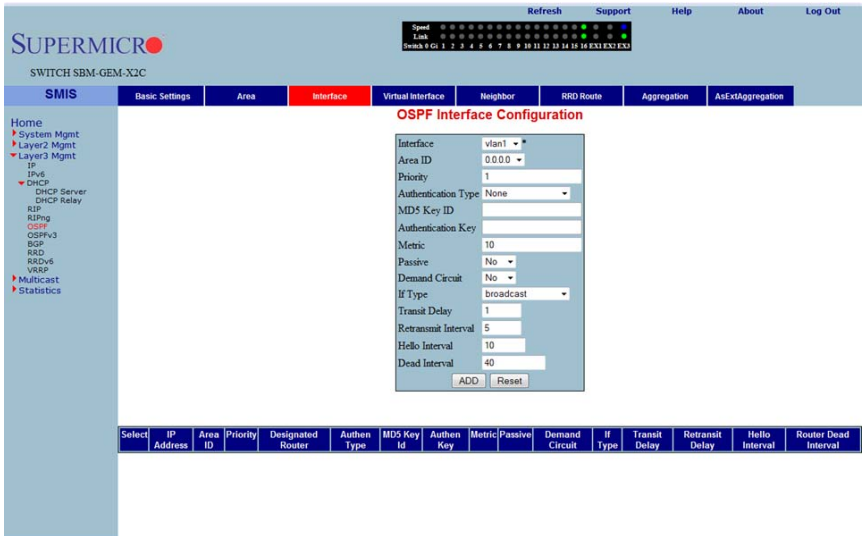

Clicking the INTERFACE tab brings up the OSPF INTERFACE CONFIGURATION page (Figure 7-119). The parameters for this page are shown in Table 7-92.

Table 7-92. OSPF Interface Configuration Page Parameters

Parameter	Description
Interface	This parameter specifies the interface index of the port.
Area ID	This parameter indicates the 32-bit integer uniquely identifying the area to which the interface connects.
Priority	This parameter specifies the priority of this interface, which is used in the DR election algorithm.
Authentication Type	This parameter allows you to choose <i>MD5</i> , <i>Simple Password</i> or <i>None</i> as the authentication type.
MD5 Key ID	This parameter specifies the secret key used to create the message digest appended to the OSPF packet, if the authentication type is <i>MD5</i> .
Authentication Key	This parameter specifies the key required for authentication, if authentication is enabled on this interface.
IP Address	This parameter specifies the IP Address of the OSPF interface.

Table 7-92. OSPF Interface Configuration Page Parameters (Continued)

Parameter	Description
Designated Router	This read-only field specifies the IP Address of the Designated Router.
Status	When this parameter is enabled, the interface is advertised as an internal route to some area. When disabled it denotes that the interface is external to OSPF.

## Virtual Interface

Figure 7-120. OSPF Virtual Interface Configuration Page

The screenshot displays the 'OSPF Virtual Interface Configuration' page. The interface includes a navigation menu on the left with options like Home, System Mgmt, Layer2 Mgmt, Layer3 Mgmt, IP, IPv6, DHCP, DHCP Server, DHCP Relay, RIP, RIPv2, OSPF, OSPFv3, BGP, RRD, RRDv6, VRRP, Multicast, and Statistics. The main content area shows the configuration form with the following fields:

- Transit Area ID
- Neighbor Router ID
- Authentication Type: None
- MD5 Key ID
- Authentication Key
- Hello Interval: 10
- Router Dead Interval: 60
- Transit Delay: 1
- Retransmit Interval: 5

Buttons for 'ADD' and 'Reset' are located at the bottom of the configuration form. A status bar at the top right shows 'Speed' and 'Link' indicators.

Clicking the VIRTUAL INTERFACE tab brings up the OSPF VIRTUAL INTERFACE CONFIGURATION page (Figure 7-120). The parameters for this page are shown in Table 7-93.

Table 7-93. OSPF Virtual Interface Configuration Page Parameters

Parameter	Description
Transit Area ID	This parameter specifies the transit area that the virtual link traverses.
Neighbor Router ID	This parameter specifies the router ID of the virtual neighbor.
Authentication Type	This parameter allows you to choose <i>MD5</i> , <i>Simple Password</i> or <i>None</i> as the authentication type.

**Table 7-93. OSPF Virtual Interface Configuration Page Parameters (Continued)**

Parameter	Description
MD5 Key ID	This parameter specifies the secret key used to create the message digest appended to the OSPF packet if the authentication type is <i>MD5</i> .
Authentication Key	This parameter specifies the key required for authentication, if authentication is enabled on this interface.

**OSPF Neighbor**

**Figure 7-121. OSPF Neighbor Configuration Page**

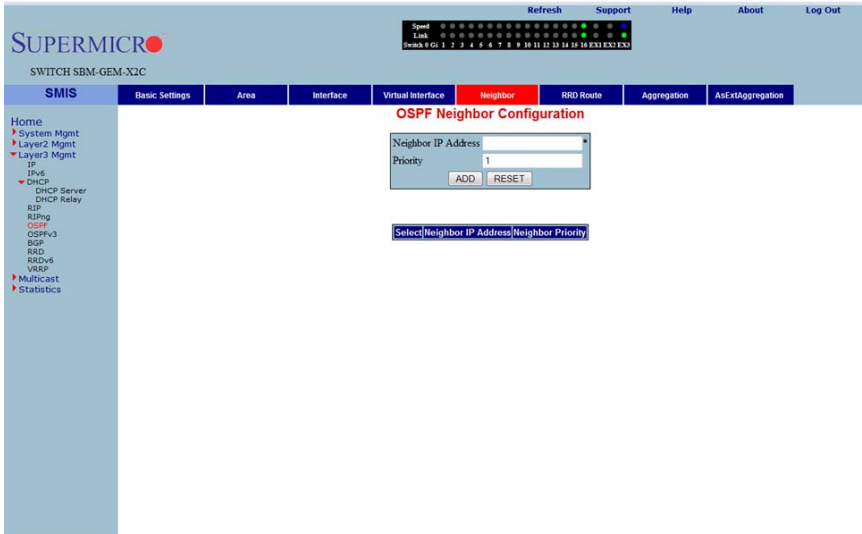

Clicking the NEIGHBOR tab brings up the OSPF NEIGHBOR CONFIGURATION page (Figure 7-121), which allows you to configure OSPF neighbors. The parameters for this page are shown in Table 7-94.

**Table 7-94. OSPF Neighbor Configuration Page Parameters**

Parameter	Description
Neighbor IP Address	This parameter specifies the neighbor router ID.
Priority	This parameter specifies a number value for the router priority.



## OSPF RRD Route Configuration

Figure 7-122. OSPF RRD Route Configuration Page

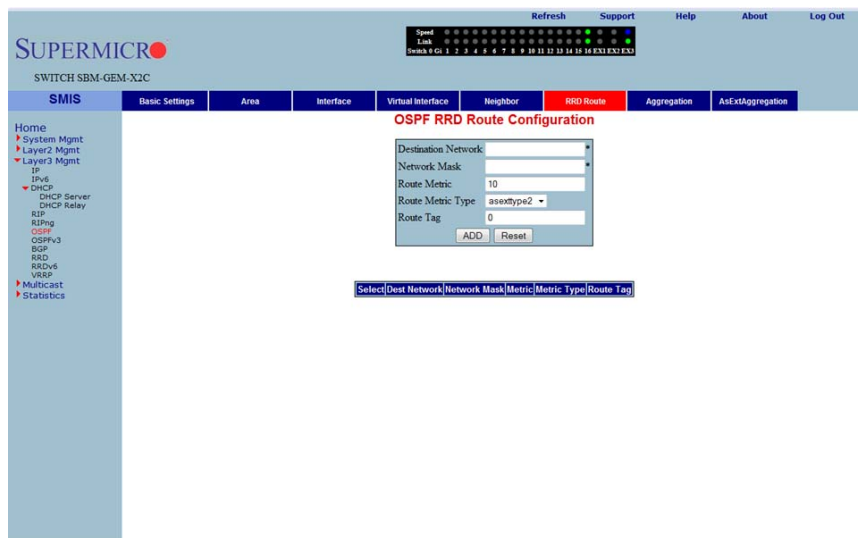

Clicking the RRD ROUTE tab brings up the OSPF RRD ROUTE CONFIGURATION page (Figure 7-122), which displays the various parameters for RRD Route configuration. The parameters for this page are shown in Table 7-95.

Table 7-95. OSPF RRD Route Configuration Page Parameters

Parameter	Description
Destination Network	This parameter specifies the DESTINATION NETWORK.
Network Mask	This parameter specifies the NETWORK MASK.
Route Metric	This parameter specifies the ROUTE METRIC.
Route Metric Type	This parameter specifies the ROUTE METRIC TYPE.
Route Tag	This parameter specifies the ROUTE TAG.

## OSPF Area Aggregation

Figure 7-123. OSPF Area Aggregation Page

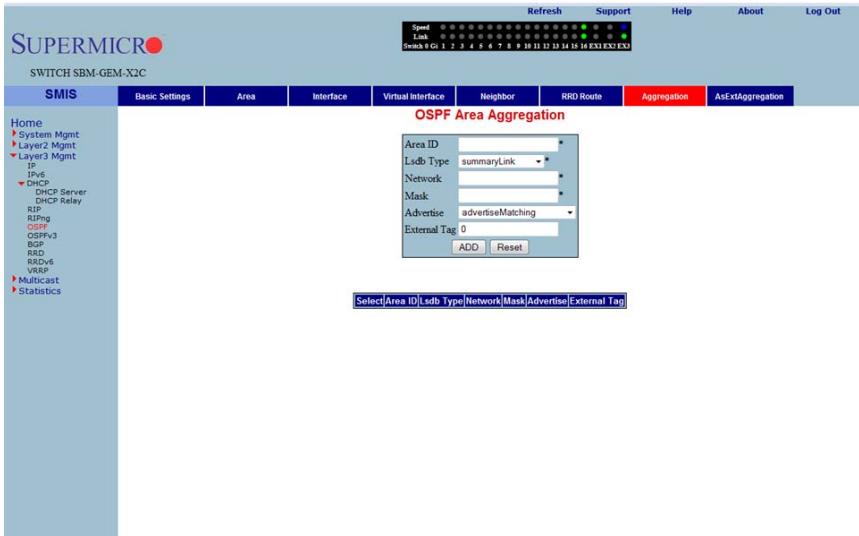

Clicking the AGGREGATION tab brings up the OSPF AREA AGGREGATION page (Figure 7-123). The parameters for this page are shown in Table 7-96.

Table 7-96. OSPF Area Aggregation Page Parameters

Parameter	Description
Area ID	This parameter specifies the area associated with the OSPF address range. It is specified as an IP address.
Lsdb Type	This parameter specifies the link state data base type as a <i>Summary Link</i> or as a <i>NSSA External Link</i> .
Network	This parameter specifies the network address.
Mask	This parameter specifies the network mask.
Advertise	This parameter specifies the advertise option as <i>Advertise Matching</i> or <i>Do Not Advertise Matching</i> .
External Tag	This parameter is not used by the OSPF protocol itself. It may be used to communicate information between AS boundary routers. The precise nature of this information is outside the scope of OSPF.

## External Aggregation

Figure 7-124. OSPF As External Aggregation Configuration Page

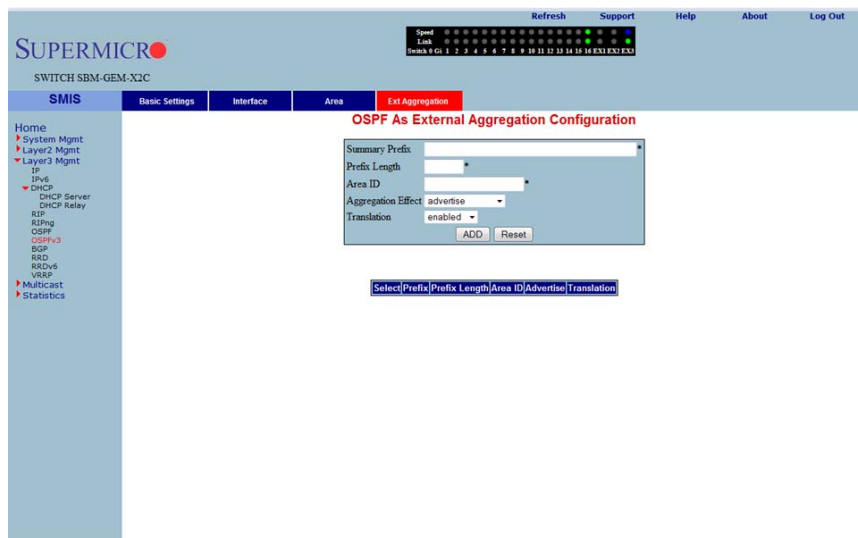

Clicking the EXT AGGREGATION tab brings up the OSPF AS EXTERNAL AGGREGATION CONFIGURATION page (Figure 7-124), which allows you to configure OSPF external aggregation parameters. The parameters for this page are shown in Table 7-97.

Table 7-97. OSPF As External Aggregation Configuration Page Parameters

Parameter	Description
Network	This parameter specifies the external network address.
Mask	This parameter specifies the network mask.
Area ID	This parameter specifies the Area identifier.

**Table 7-97. OSPF As External Aggregation Configuration Page Parameters**

Parameter	Description
Aggregation Effect	<p>This parameter specifies the Aggregation option as one of the following:</p> <ul style="list-style-type: none"> <li>• <b>Advertise</b> – When set to <i>advertise</i> and associated Area ID is 0.0.0.0, then the aggregated Type-5 are generated. Otherwise if the associated Area ID is x.x.x.x (other than 0.0.0.0), then the aggregated Type-7 is generated in NSSA x.x.x.x for the specified range.</li> <li>• <b>Do Not Advertise</b> – When set to <i>doNotAdvertise</i> (2) and associated Area ID is 0.0.0.0, then the Type-5 is not generated for the specified range, while aggregated Type-7 are generated in all attached NSSA. While if the associated Area ID is x.x.x.x (other than 0.0.0.0), then the Type-7 are not generated in NSSA x.x.x.x for the specified range.</li> <li>• <b>Allow All</b> – When set to <i>allowAll</i> and associated Area ID is 0.0.0.0, then the aggregated Type-5 are generated for the specified range. In addition aggregated Type-7 are generated in all attached NSSA for the specified range.</li> <li>• <b>Deny All</b> – When set to <i>denyAll</i> neither Type-5 nor Type-7 will be generated for the specified range.</li> </ul>
Translation	This parameter enables or disables the translation.

## OSPF V3

The OSPFv3 link allows you to configure the OSPFv3 protocol through the following pages:

- "OSPFv3 Basic Settings" on page 7-141
- "Interface" on page 7-142
- "Area" on page 7-144
- "OSPF V3 External Aggregation" on page 7-145

### OSPFv3 Basic Settings

Figure 7-125. OSPFv3 Basic Settings Page

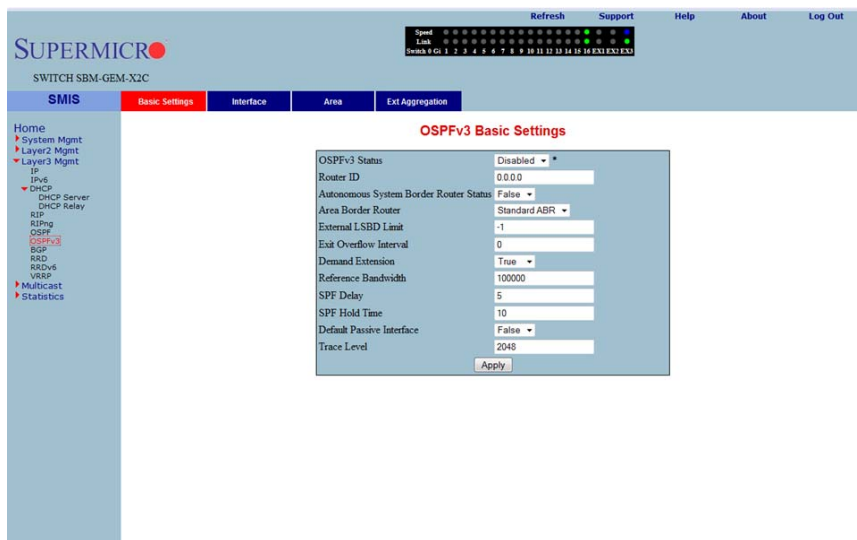

Clicking the BASIC SETTINGS tab brings up the OSPFv3 BASIC SETTINGS page (Figure 7-125). The parameters for this page are shown in Table 7-98.

Table 7-98. OSPFv3 Basic Settings Page Parameters

Parameter	Description
OSPFv3 Status	This parameter enables or disables OSPFv3 administratively.
Router ID	This parameter uniquely identifies the router in the Autonomous System.
Autonomous System Border Router Status	This parameter specifies the router as Autonomous System border router.
Area Border Router	This parameter specifies the router as an area border router.

**Table 7-98. OSPFv3 Basic Settings Page Parameters (Continued)**

Parameter	Description
External LSDB Limit	This parameter specifies maximum number of non-default AS-external-LSAs entries that can be stored in the link-state database.
Exit Overflow Interval	This parameter specifies the time interval in seconds a router will attempt to leave OverflowState.
Demand Extension	This parameter indicates the router's support for demand routing.
Reference Bandwidth	This parameter specifies Reference bandwidth in kilobits/seconds, for calculating default interface metrics.
SPF Delay	This parameter indicates the delay in routing calculation after a topology change.
SPF Hold Time	This parameter specifies the minimum time between two consecutive SPF calculations.
Default Passive Interface	This parameter specifies whether all the OSPFv3 interfaces created after this setting are passive or not.
Trace Level	This parameter defines the level of trace required for OSPFv3.

**Interface**

**Figure 7-126. Interface Settings Page**

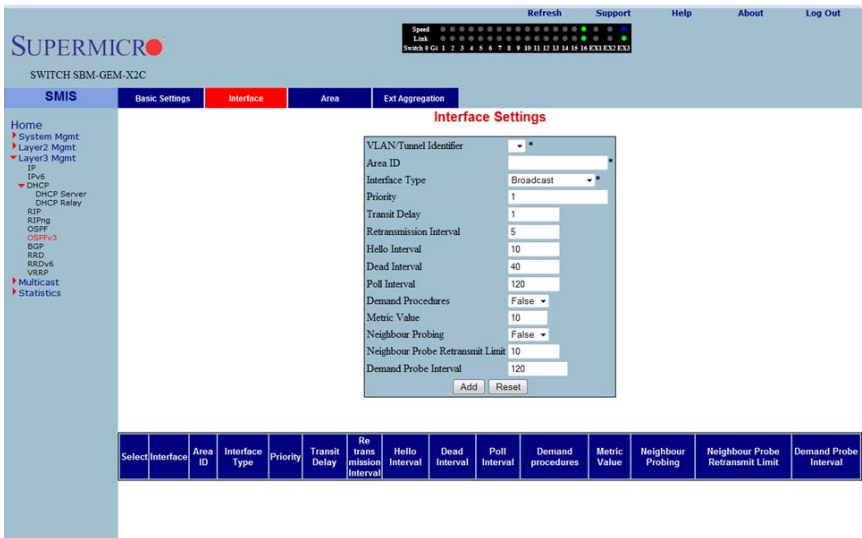

Clicking the INTERFACE tab brings up the INTERFACE SETTINGS page (Figure 7-126). The parameters for this page are shown in Table 7-99.

**Table 7-99. Interface Settings Page Parameters**

Parameter	Description
VLAN/Tunnel Identifier	This parameter specifies the IPv6 interface over which OSPFv3 is enabled.
Area ID	This parameter specifies the area ID associated with the IPv6 interface.
Interface Type	This parameter specifies the type of OSPFv3 interface (broadcast, nbma, pointToPoint and pointToMultipoint).
Priority	This parameter specifies the priority of the interface.
Transit Delay	This parameter indicates the estimated number of seconds to transmit a link state update packet over the interface.
Retransmission Interval	This parameter indicates the number of seconds between the link-state advertisement retransmissions, for adjacencies belonging to the interface.
Hello Interval	This parameter indicates the length of time, in seconds, between the Hello packets that the router sends on the interface.
Dead Interval	This parameter specifies the number of seconds for which the router waits for hello packet from the neighbor before declaring this neighbor down.
Poll Interval	This parameter denotes the larger time interval, in seconds, between the Hello packets sent to an inactive non-broadcast multi- access neighbor.
Demand Procedures	This parameter indicates whether Demand OSPFv3 procedures must be performed on this interface.
Metric Value	This parameter specifies the metric assigned to this interface.
Neighbour Probing	This parameter enables or disables neighbor probing to determine whether the neighbor is active or inactive.
Neighbour Probe Retransmit Limit	This parameter indicates the number of consecutive LSA retransmissions before the neighbor is deemed inactive and the neighbor adjacency is brought down.
Demand Probe Interval	This parameter defines how often the neighbor is probed.

Area

Figure 7-127. OSPFv3 Area Settings Page

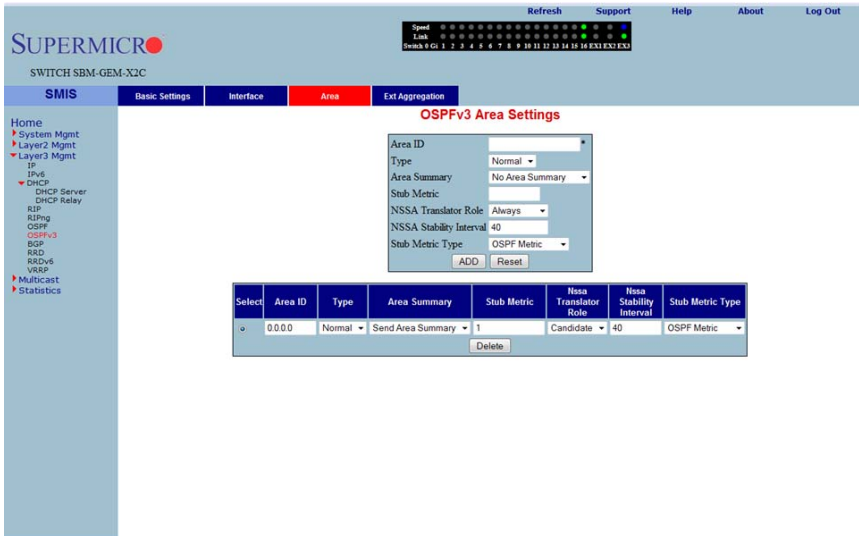

Clicking the AREA tab brings up the OSPFV3 AREA SETTINGS page (Figure 7-127). The parameters for this page are shown in Table 7-100.

Table 7-100. OSPFv3 Area Settings Page Parameters

Parameter	Description
Area ID	This parameter uniquely identifies an area.
Type	This parameter indicates whether an area is a <i>Stub</i> area, <i>NSSA</i> , or <i>Standard</i> (normal) area.
Area Summary	This parameter controls the import of Inter-Area LSAs into stub areas. This can be <i>noAreaSummary</i> or <i>sendAreaSummary</i> .
Stub Metric	This parameter indicates the metric value advertised for the default route into <i>Stub</i> area and <i>NSSA</i> .
NSSA Translator Role	This parameter specifies the NSSA Border router's ability to perform NSSA translation of type-7 LSAs into type-5 LSAs.
NSSA Stability Interval	This parameter specifies the number of seconds after an elected translator determines its services are no longer required, in which it must continue to perform its translation duties.
Stub Metric Type	This parameter specifies the type of metric ( <i>OSPFv3 Metric</i> , <i>External Type 1</i> , <i>External Type 2</i> ) advertised as a default route.



## OSPF V3 External Aggregation

Figure 7-128. OSPF AS External Aggregation Configuration Page

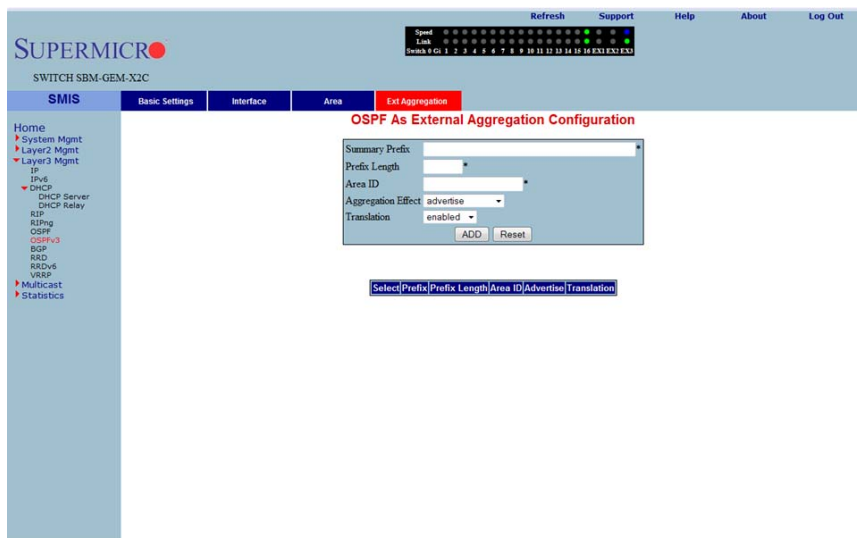

Clicking the EXT AGGREGATION tab brings up the OSPF AS EXTERNAL AGGREGATION CONFIGURATION page (Figure 7-128), which allows you to configure OSPF external aggregation parameters. The parameters for this page are shown in Table 7-101.

Table 7-101. OSPF AS External Aggregation Configuration Page Parameters

Parameter	Description
Network	This parameter specifies the external network address.
Mask	This parameter specifies the network mask.
Area ID	This parameter specifies the Area identifier.

**Table 7-101. OSPF AS External Aggregation Configuration Page Parameters**

Parameter	Description
Aggregation Effect	<p>This parameter specifies the Aggregation option as one of the following:</p> <ul style="list-style-type: none"> <li>• <b>Advertise</b> – When set to <i>advertise</i> and the associated Area ID is 0.0.0.0, then aggregated Type-5 are generated. Otherwise if associated Area ID is x.x.x.x (other than 0.0.0.0), then aggregated Type-7 is generated in NSSA x.x.x.x for the specified range.</li> <li>• <b>Do Not Advertise</b> – When set to <i>doNotAdvertise (2)</i> and the associated Area ID is 0.0.0.0, then Type-5 is not generated for the specified range, while aggregated Type-7 are generated in all attached NSSA. While associated Area ID is x.x.x.x (other than 0.0.0.0), then Type-7 are not generated in NSSA x.x.x.x for the specified range.</li> <li>• <b>Allow All</b> – When set to <i>allowAll</i> and associated Area ID is 0.0.0.0, then aggregated Type-5 are generated for the specified range. In addition aggregated Type-7 are generated in all attached NSSA, for the specified range.</li> <li>• <b>Deny All</b> – When set to <i>denyAll</i> neither Type-5 nor Type-7 will be generated for the specified range.</li> </ul>
Translation	This parameter enables or disables the translation.

## BGP

The BGP link allows you to configure the BGP protocol. Following are the configuration parameters available to manage BGP through this interface:

- "BGP Basic Settings" on page 7-147
- "BGP Peer Configuration" on page 7-148
- "BGP MED Configuration" on page 7-149
- "Local Preference" on page 7-150
- "BGP Filter" on page 7-152
- "Route Aggregations" on page 7-153
- "Advanced BGP Configuration" on page 7-154
- "BGP Community Management" on page 7-155

### BGP Basic Settings

Figure 7-129. BGP Basic Settings Page

The screenshot shows the SUPERMICR SMIS web interface. The top navigation bar includes 'Refresh', 'Support', 'Help', 'About', and 'Log Out'. The main navigation tabs are 'SMIS', 'Basics', 'Neighbors', 'Multi-Exit Disc', 'Local Pref', 'Filters', 'Route Aggr', 'Advanced', and 'Community'. The 'Basics' tab is selected, and the 'BGP Basic Settings' page is displayed. The configuration form contains the following fields:

Status	Disabled
AS Number	0
Router ID	0.0.0.0
Synchronization	Disabled
Overlap Router Policy	Both
Default Local Preference	100
Advertisement of Non - BGP Routes	ExternalAndInternal
Always Compare MED	Disabled

Apply

Note: To enable BGP Functionality, **Route Redistribution** should be enabled.

Clicking the BASICS tab brings up the BGP BASIC SETTINGS page (Figure 7-129). The parameters for this page are shown in Table 7-102.

**Table 7-102. BGP Basic Settings Page Parameters**

Parameter	Description
Status	This parameter specifies the BGP admin status. Using this, the protocol can be enabled/disabled in the switch.
AS Number	This parameter specifies the autonomous system to which the switch is connected, which is a read-only field.
Synchronization	The synchronization between IGP and BGP can be ensured by enabling this field.
Overlap Router Policy	This parameter represents the policy for handling overlapping routes. When an overlapping route is received, depending upon the configured policy, either the less-specific routes or most-specific routes or both are installed in the RIB tree.
Default Local Preference	This parameter sets a preference value for the autonomous system path.
Advertisement of Non-BGP Routes	You can choose to advertise even the external non-BGP routes by enabling this feature.
Always Compare MED	By enabling this feature, you can choose to always compare the MED values of paths from different neighbors for the same prefix, for choosing the best path.

**BGP Peer Configuration**

**Figure 7-130. BGP Peer Configuration Page**

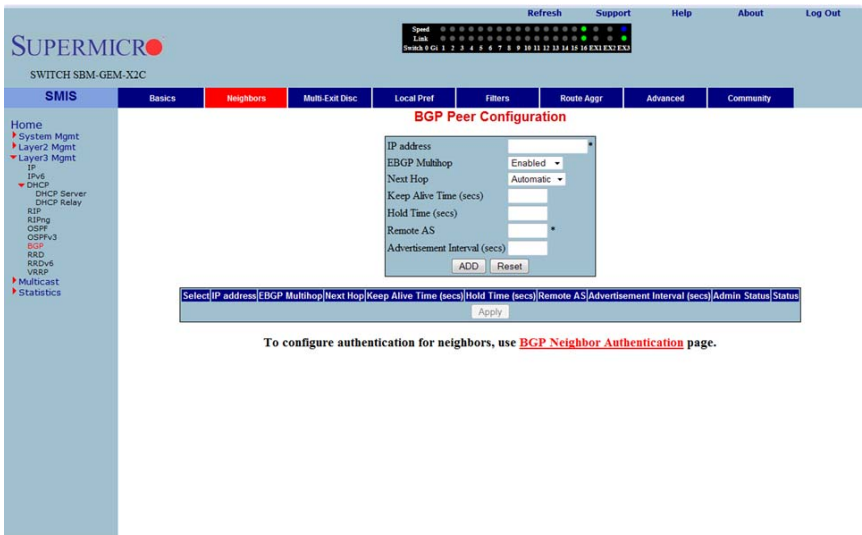

Clicking the NEIGHBORS tab brings up the BGP PEER CONFIGURATION page (Figure 7-130), which allows you to configure BGP Neighbors. The parameters for this page are shown in Table 7-103.

**Table 7-103. BGP Peer Configuration Page Parameters**

Parameter	Description
IP Address	This parameter specifies the IP address of the BGP neighbor.
EBGP MultiHop	By enabling this feature, BGP connections can be established between peers, which are not directly connected.
Next Hop	Using this parameter, next Hop can be set as <i>Self</i> or <i>Automatic</i> . By setting this field to <i>Self</i> , you can make the switch the next hop for all the routes that it distributes to its peers.
Keep Alive Time (Seconds)	This parameter specifies the maximum time interval between successive updates between any two BGP peers.
Hold Time (Seconds)	This parameter specifies the Hold time. This is the timer interval that a BGP will wait, before it decides that a connection to the peer is torn down.
Remote AS	This parameter represents the remote autonomous system number.
Advertisement Interval (seconds)	This parameter specifies the interval in seconds for the Minimum Route advertisement interval timer.
Status	This parameter specifies the status of the entry.

## BGP MED Configuration

**Figure 7-131. BGP MED Configuration Page**

The screenshot displays the BGP MED Configuration page. At the top, there is a status bar with 'Speed' and 'Link' indicators. The navigation menu includes 'SMIS', 'Basics', 'Neighbors', 'Multi-Exit Disc', 'Local Pref', 'Filters', 'Route Aggr', 'Advanced', and 'Community'. The 'Neighbors' tab is active, showing the 'BGP MED Configuration' form. The form fields are: MED ID (text), Remote AS (text), IP Address Prefix (text), IP Address Prefix Length (text), Intermediate AS (text), Direction (dropdown menu set to 'In'), Value (text), and Preference (dropdown menu set to 'False'). There are 'ADD' and 'Reset' buttons at the bottom of the form. Below the form is a table with columns: Select, MED ID, Remote AS, IP Address Prefix, Prefix Length, Intermediate AS, Direction, Value, Preference, and Status. An 'Apply' button is located below the table.

Clicking the MULTI-EXIT DISC tab brings up the BGP MED CONFIGURATION page (Figure 7-131), which allows you to configure the MED value for routes learnt from BGP peers. The parameters for this page are shown in Table 7-104.

**Table 7-104. BGP MED Configuration Page Parameters**

Parameter	Description
MED ID	This parameter specifies the index for this table.
Remote AS	This parameter specifies the AS number from which the route update is received.
IP Address Prefix	This parameter specifies the IP address prefix for which the update is received.
IP Address Prefix Length	This parameter is used to calculate the subnet.
Intermediate AS	This parameter represents the intermediate AS between the BGP peers.
Direction	This parameter can be set for the incoming or the outgoing packets using <i>In</i> and <i>Out</i> values.
Value	This parameter specifies the MED value to be associated with this path learnt.
Preference	This parameter is used to enable/disable filtering.
Status	This parameter indicates the status of the entry.

**Local Preference**

**Figure 7-132. BGP Local Preference Configuration Page**

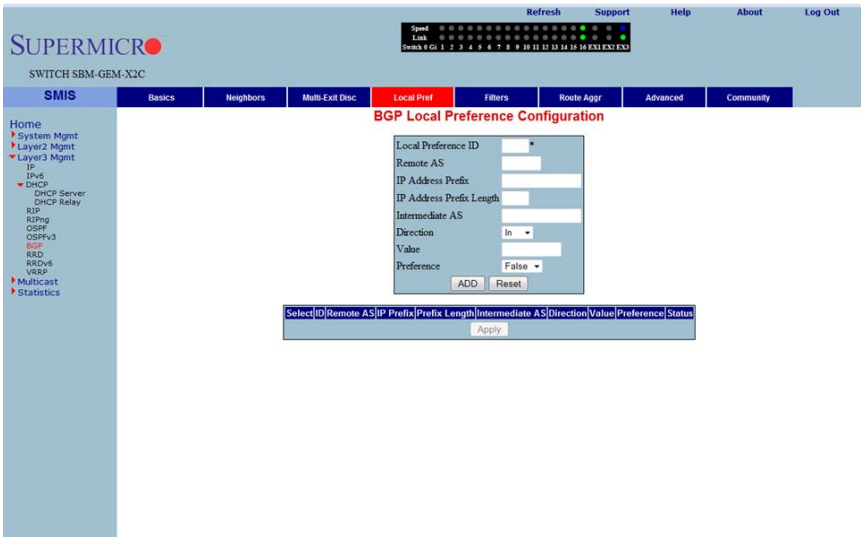

Clicking the LOCAL PREF tab brings up the BGP LOCAL PREFERENCE CONFIGURATION page (Figure 7-132), which allows you to configure the Local Preference value for routes. The parameters for this page are shown in Table 7-105.

**Table 7-105. BGP Local Preference Configuration Page Parameters**

Parameter	Description
Local Preference ID	This parameter specifies the Local Preference ID, which is the index for this table.
Remote AS	This parameter specifies the AS number from which the route update is received.
IP Address Prefix	This parameter specifies the IP Address prefix for which the update is received.
IP Address Prefix Length	This parameter is used to calculate the subnet.
Intermediate AS	This parameter represents the intermediate AS between the BGP peers.
Direction	This parameter can be set for the incoming or the outgoing packets using <i>In</i> and <i>Out</i> values.
Value	This parameter specifies the Local preference value to be associated with this learnt path.
Preference	This parameter is used to enable/disable filtering.
Status	This parameter specifies the status of the entry.

**BGP Filter**

**Figure 7-133. BGP Filter Configuration Page**

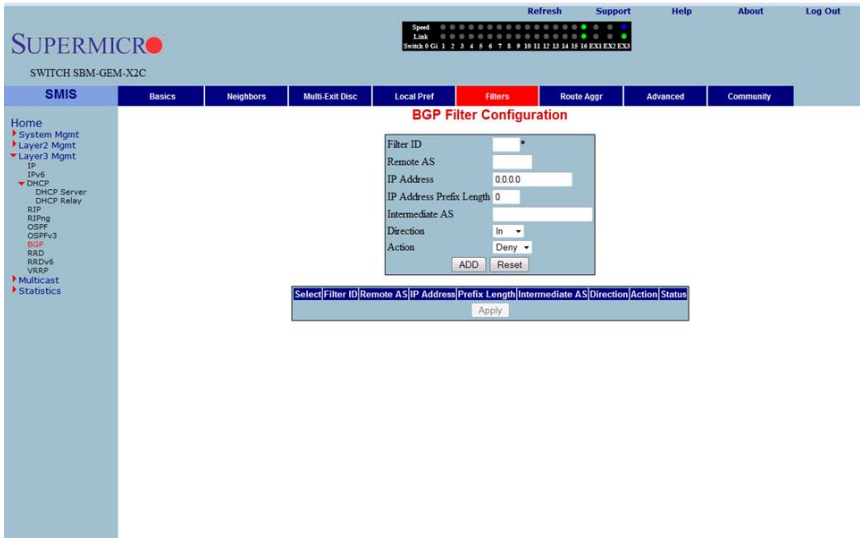

Clicking the FILTERS tab brings up the BGP FILTER CONFIGURATION page (Figure 7-133), which is used to set the filters on the routes being learnt. The parameters for this page are shown in Table 7-106.

**Table 7-106. BGP Filter Configuration Page Parameters**

Parameter	Description
Filter ID	This parameter specifies the filter index.
Remote AS	This parameter specifies the remote AS associated with the BGP peer from which the router is being distributed.
IP Address	This parameter specifies the IP address for which the route is being learnt.
IP Address Prefix Length	This parameter specifies the prefix length to calculate the Subnet.
Intermediate AS	This parameter represents the intermediate AS between the BGP peers.
Direction	This parameter indicates the direction of the packet.
Action	With this parameter you can choose either to <i>Allow</i> (not to filter) or <i>Deny</i> (Filter) for the above configuration set.
Status	This parameter specifies the status of the entry.



## Route Aggregations

Figure 7-134. BGP Route Aggregation Configuration Page

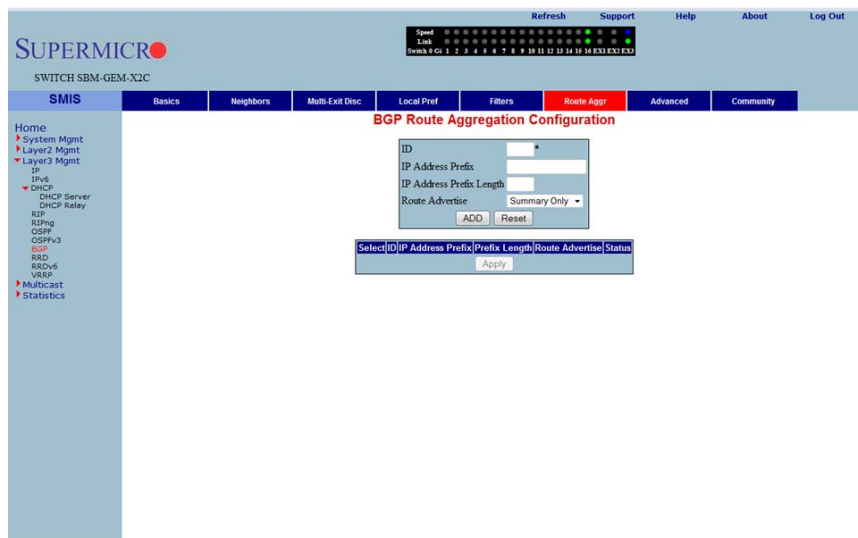

Clicking the ROUTE AGGR tab brings up the BGP ROUTE AGGREGATION CONFIGURATION page (Figure 7-134), which is used to aggregate and configure the routes advertised by BGP. The parameters for this page are shown in Table 7-107.

Table 7-107. BGP Route Aggregation Configuration Page Parameters

Parameter	Description
ID	This parameter specifies the index to this table.
IP Address Prefix	This parameter specifies the IP address prefix that needs to be aggregated.
IP Address Prefix Length	This parameter, in combination with the IP Prefix, decides the aggregated route to be distributed by this switch.
Route Advertise	With this parameter you can either choose to advertise only the aggregated routes by setting <i>Summary only</i> , or choose to advertise all routes by setting <i>All</i> .
Status	This parameter specifies the status of the entry.

**Advanced BGP Configuration**

**Figure 7-135. Advanced BGP Configuration Page**

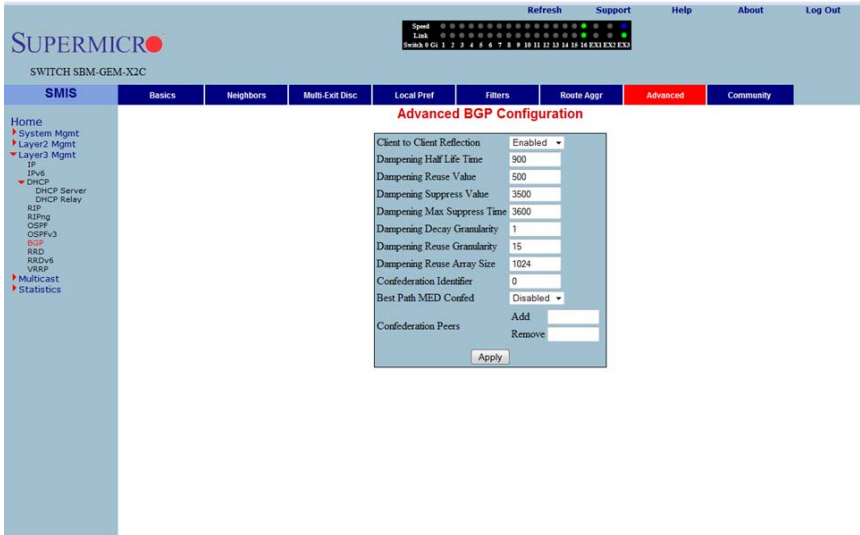

Clicking the **ADVANCED** tab brings up the **ADVANCED BGP CONFIGURATION** page (Figure 7-135), which configures dampening and confederation parameters. The parameters for this page are shown in Table 7-108.

**Table 7-108. Advanced BGP Configuration Page Parameters**

Parameter	Description
Client to Client Reflection	<p>This parameter configures the Route Reflector to support route reflection to client peers.</p> <p>By default, the Route Reflector will reflect routes learnt from a client peer to all other client peers. If required, the administrator can disable this feature by disabling client-to-client reflection.</p> <p>If disabled, then the Route Reflector will not advertise routes learnt from a client peer to other client peers. This occurs when all peers within a cluster are fully-meshed and the client peer itself is able to advertise routes to other clients of the route-reflector.</p>
Dampening Half Life Time	This parameter specifies the time (in seconds) after which a penalty is decreased by half. Once a route has been assigned a penalty, the penalty is decreased by half after the half-life time.
Dampening Reuse Value	If the penalty associated with a suppressed route falls below this value, the route is re-used.
Dampening Suppress Value	A route is suppressed when the penalty associated with the route exceeds this value.

**Table 7-108. Advanced BGP Configuration Page Parameters (Continued)**

Parameter	Description
Dampening Max Suppress Time	This parameter specifies the maximum time (in seconds) a route can be suppressed.
Dampening Decay Granularity	This parameter specifies the time granularity in seconds used to perform all decay computations.
Dampening Reuse Granularity	This parameter specifies the time interval between evaluations of the reuse-lists. Each reuse lists corresponds to an additional time increment.
Dampening Reuse Array Size	This parameter specifies the size of the reuse index arrays. This size determines the accuracy with which suppressed routes can be placed within the set of reuse lists, when suppressed for a long time.
Confederation Identifier	This parameter specifies the BGP confederation identifier. The possible values are between 1 to 65535. Configuring 0 removes the existing configuration.
Best Path MED Confed	This parameter enables or disables MED comparison among paths learnt from confed peers.
Confederation Peers	This parameter configures the ASs that belongs to the confederation.

## BGP Community Management

**Figure 7-136. BGP Community Management Page**

The screenshot shows the BGP Community Management page. At the top, there are links for Refresh, Support, Help, About, and Log Out. Below these is a status bar with Speed and Link indicators. The main navigation bar includes tabs for SMIS, Basics, Neighbors, Multi-Ext Desc, Local Pref, Filters, Route Aggr, Advanced, and Community (which is highlighted in red). The left sidebar contains a tree view of system management options. The main content area is titled 'BGP Community Management' and contains two panels:

- Community Configurations:**
  - Community Route Configurations: Add, Delete
  - Community Filter Configurations: In Filter, Out Filter
  - Community Peer Configurations
  - Community Policy Configurations
- Extended Community Configurations:**
  - Extended Community Route Configurations: Add, Delete
  - Extended Community Filter Configurations: In Filter, Out Filter
  - Extended Community Peer Configurations
  - Extended Community Policy Configurations

Clicking the **COMMUNITY** tab brings up the **BGP COMMUNITY MANAGEMENT** page (Figure 7-136), which configures BGP community and extended community parameters. The parameters for this page are shown in Table 7-109.

**Table 7-109. BGP Community Management Page Parameters**

Parameter	Description
Community Route Configurations	This parameter configures an entry in the Additive or Delete Community table.
Community Filter Configurations	This parameter configures the permit or deny function for the community attribute while receiving or advertising.
Community Peer Configurations	This parameter enables or disables advertisement of community attributes to the peer.
Community Policy Configurations	This parameter configures the community attribute advertisement policy for a specific destination.
Extended Community Route Configurations	This parameter configures an entry in the Additive or Delete Extended Community table.
Extended Community Filter Configurations	This parameter configures the permit or deny function for the Extended Community attribute while receiving or advertising.
Extended Community Peer Configurations	This parameter enables or disables advertisement of the Extended Community attributes to the peer.
Extended Community Policy Configurations	This parameter configures the Extended Community attribute advertisement policy for the specific destination.

## RRD

The RRD link allows you to manage the Route Redistribution with the help of the following pages:

- ["RRD Basic Settings" on page 7-157](#)
- ["BGP" on page 7-158](#)
- ["RIP" on page 7-159](#)
- ["OSPF" on page 7-160](#)

## RRD Basic Settings

Figure 7-137. RRD Basic Settings Page

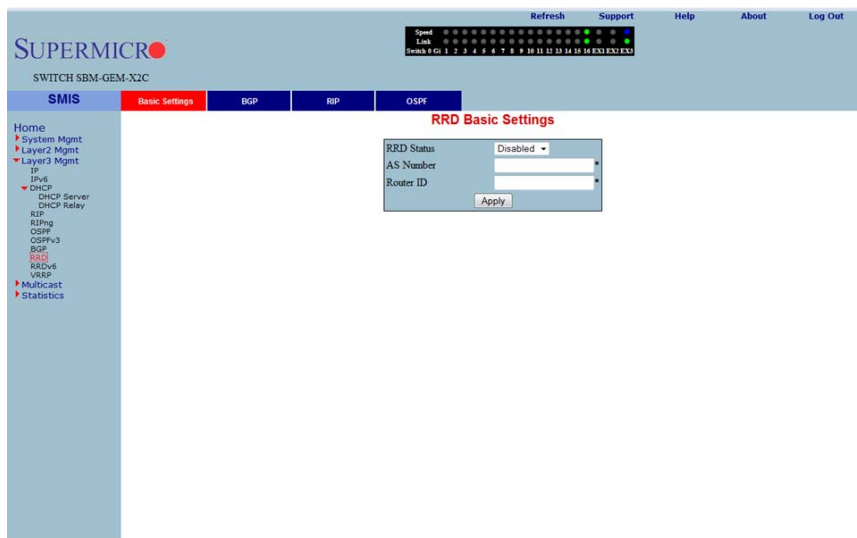

Clicking the BASIC SETTINGS tab brings up the RRD BASIC SETTINGS page (Figure 7-137). The parameters for this page are shown in Table 7-110.

Table 7-110. RRD Basic Settings Page Parameters

Parameter	Description
RRD Status	By enabling this parameter, Route Re-distribution can be enabled in the switch.
AS Number	This parameter is used to configure the Router AS number to which this switch belongs.
Router ID	This parameter represents the Router ID of the switch.

**BGP**

**Figure 7-138. RRD BGP Configuration Page**

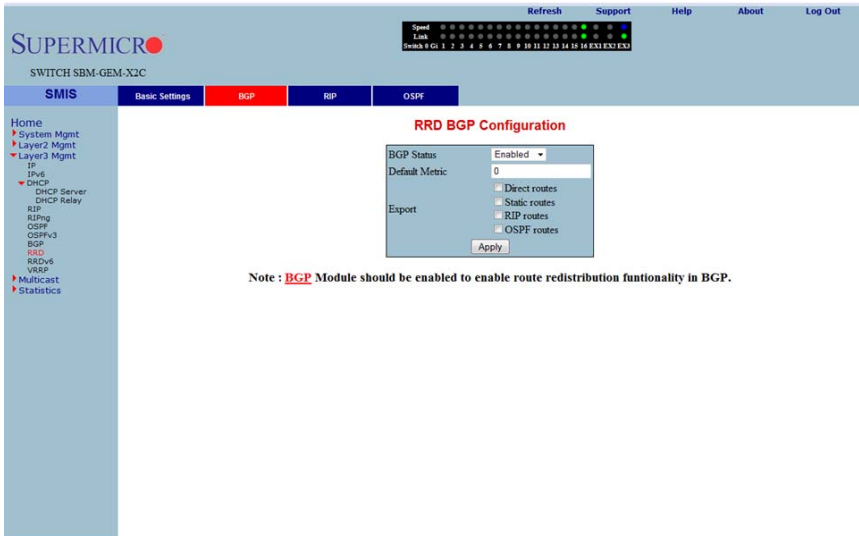

Clicking the BGP tab brings up the RRD BGP CONFIGURATION page (Figure 7-138), which allows you to re-distribute the routes that are learnt through other routing protocols to BGP. The parameters for this page are shown in Table 7-111.

**Table 7-111. RRD BGP Configuration Page Parameters**

Parameter	Description
BGP Status	This parameter enables or disables redistribution for BGP.
Default Metric	This parameter specifies the metric for the routes that are being re-distributed.
Import	With this parameter you can choose to import <i>Direct routes</i> , <i>Static routes</i> , <i>RIP routes</i> and/or <i>OSPF routes</i> to BGP.

## RIP

Figure 7-139. RRD RIP Configuration Page

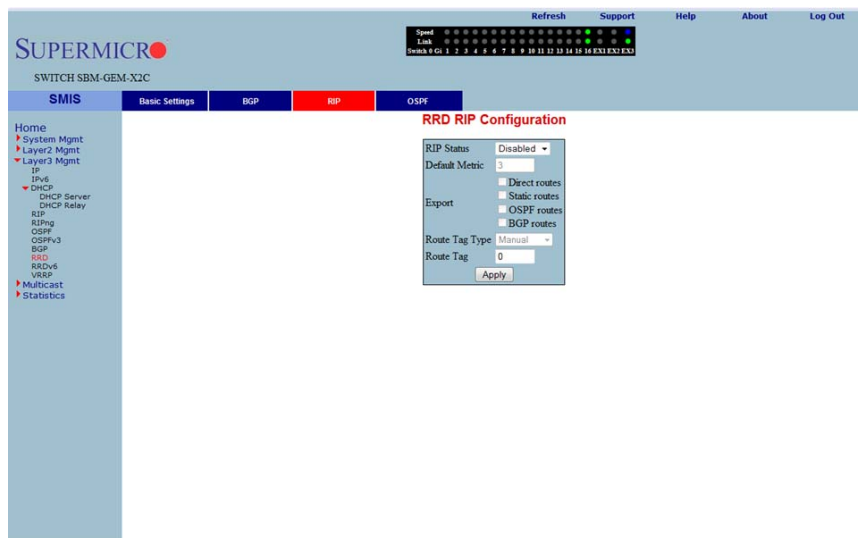

Clicking the RIP tab brings up the RRD RIP CONFIGURATION page (Figure 7-139), which allows you to re-distribute the routes that are learnt through other routing protocols to RIP. The parameters for this page are shown in Table 7-112.

Table 7-112. RRD RIP Configuration Page Parameters

Parameter	Description
RIP Status	This parameter enables or disables redistribution for RIP.
Default Metric	This parameter specifies the metric for the routes that are being re-distributed.
Import	You can use this parameter to choose to import <i>Direct routes</i> , <i>Static routes</i> , <i>OSPF routes</i> and <i>BGP routes</i> to RIP.
Route Tag Type	This parameter describes whether a tag is <i>manually</i> configured or <i>automatically</i> generated.
Route Tag	This parameter indicates the route tag in case you configure a manual option for the tag type.

## OSPF

Figure 7-140. RRD OSPF Configuration Page

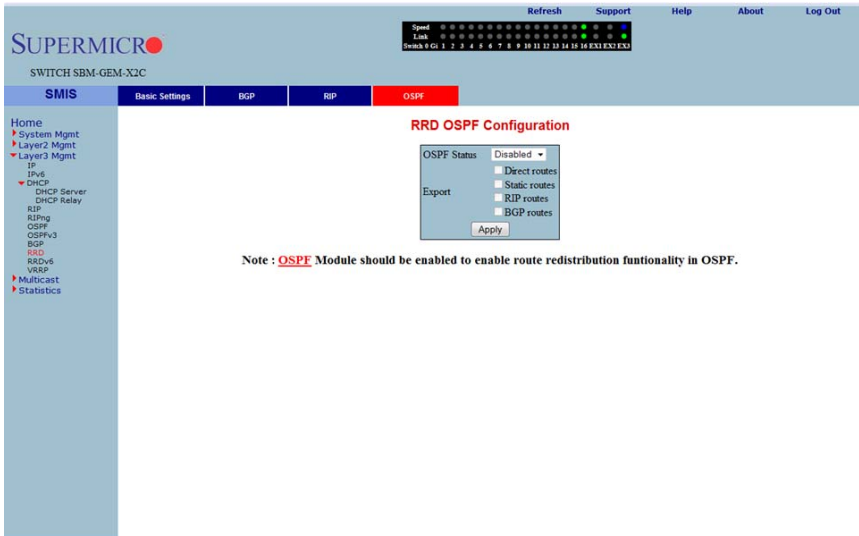

Clicking the OSPF tab brings up the RRD OSPF CONFIGURATION page (Figure 7-140), which allows you to e-distribute the routes that are learnt through other routing protocols to OSPF. The parameters for this page are shown in Table 7-113.

Table 7-113. RRD OSPF Configuration Page Parameters

Parameter	Description
OSPF Status	This parameter enables or disables redistribution for OSPF.
Import	With this parameter you can choose to import <i>Direct routes</i> , <i>Static routes</i> , <i>RIP routes</i> and <i>BGP routes</i> to OSPF.



## RRD6

The RRD6 link allows you to perform RRD6 related configuration through the following pages.

- "RRD6 Basic Settings" on page 7-161
- "Filters" on page 7-162
- "RRD V6 OSPF" on page 7-163
- "RRD RIP" on page 7-164

### *RRD6 Basic Settings*

Figure 7-141. RRD6 Basic Settings Page

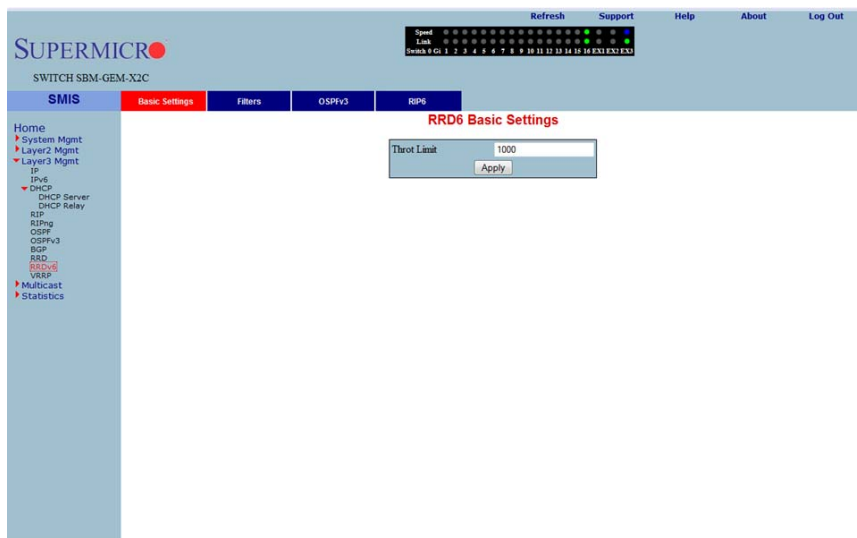

Clicking the BASIC SETTINGS tab brings up the RRD6 BASIC SETTINGS page (Figure 7-141), which has the single parameter option of changing the throat limit for RRD6.

**Filters**

**Figure 7-142. RRD6 Filter Configuration Page**

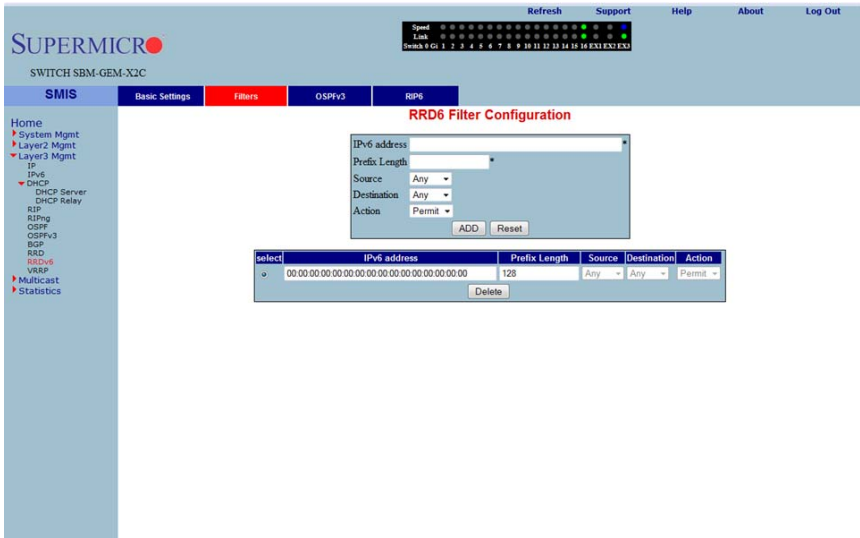

Clicking the FILTERS tab brings up the RRD6 FILTER CONFIGURATION page (Figure 7-142). The parameters for this page are shown in Table 7-114.

**Table 7-114. RRD6 Filter Configuration Page Parameters**

Parameter	Description
IPv6 address	This parameter specifies the IPv6 Address.
Prefix Length	This parameter indicates the length of the prefix (in bits) associated with this entry's IPv6 address.
Source	This parameter denotes the address of the Source.
Destination	This parameter specifies the address of the Destination.
Action	With this parameter you can either choose to <i>Permit</i> (not to filter) or <i>Deny</i> (Filter) for the above configuration set.

## RRD V6 OSPF

Figure 7-143. RRD6 OSPFv3 Configuration Page

Clicking the OSPFv3 tab brings up the RRD6 OSPFv3 CONFIGURATION page (Figure 7-143). The parameters for this page are shown in Table 7-115.

Table 7-115. RRD6 OSPFv3 Configuration Page Parameters

Parameter	Description
Status	This parameter enables or disables redistribution for OSPFv3.
Import	With this parameter you can choose to import <i>Direct routes</i> , <i>Static routes</i> or <i>RIPv6 routes</i> .

**RRD RIP**

**Figure 7-144. RRD RIPv6 Configuration Page**

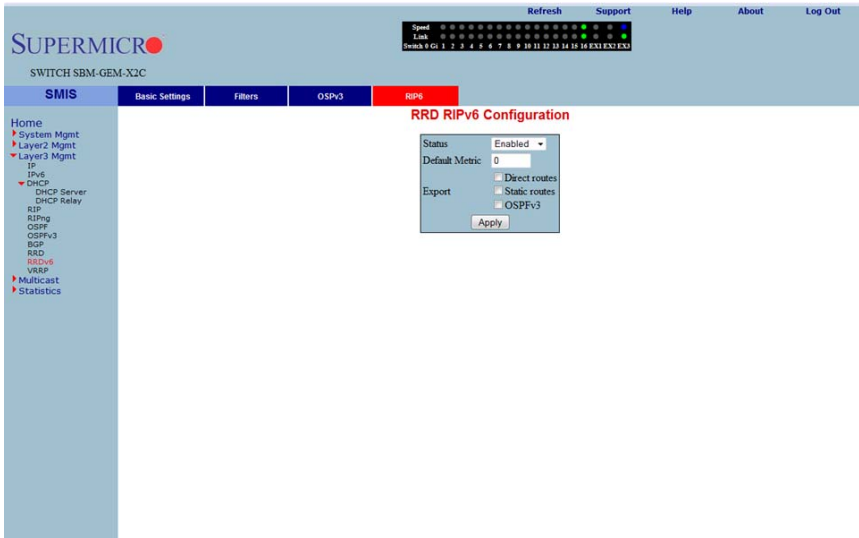

Clicking the RRP6 tab brings up the RRD RIPv6 CONFIGURATION page (Figure 7-144). The parameters for this page are shown in Table 7-116.

**Table 7-116. RRD RIPv6 Configuration Page Parameters**

Parameter	Description
Status	This parameter enables or disables redistribution for RIP6.
Default Metric	This parameter specifies the metric for the routes that are being re-distributed.
Import	With this parameter you can choose to import <i>Direct routes</i> , <i>Static routes</i> or <i>OSPFv3 routes</i> .

## VRRP

The VRRP link allows you to configure VRRP through the following two pages:

- "VRRP Basic Settings" on page 7-165
- "VRRP Settings" on page 7-166

### VRRP Basic Settings

Figure 7-145. VRRP Basic Settings Page

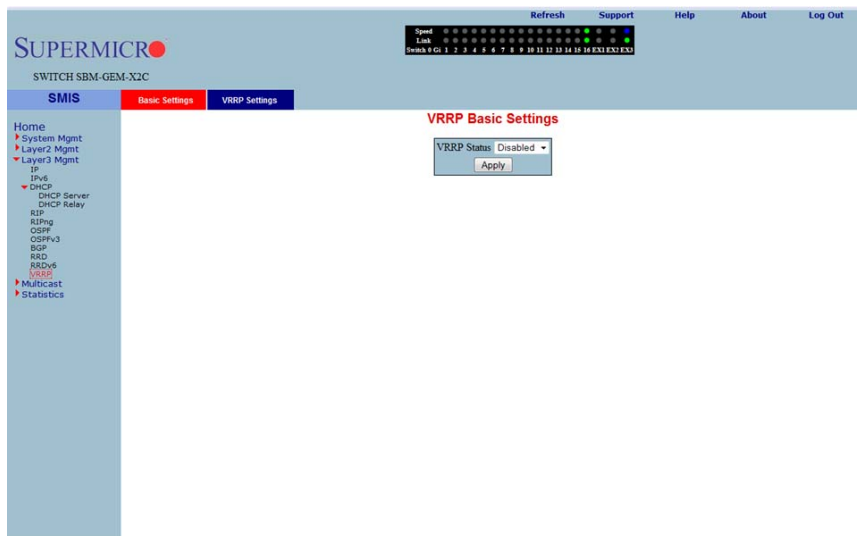

Clicking the BASIC SETTINGS tab brings up the VRRP BASIC SETTINGS page (Figure 7-145), whose single parameter allows you to specify the status of VRRP in the switch.

## VRRP Settings

Figure 7-146. VRRP Settings Page

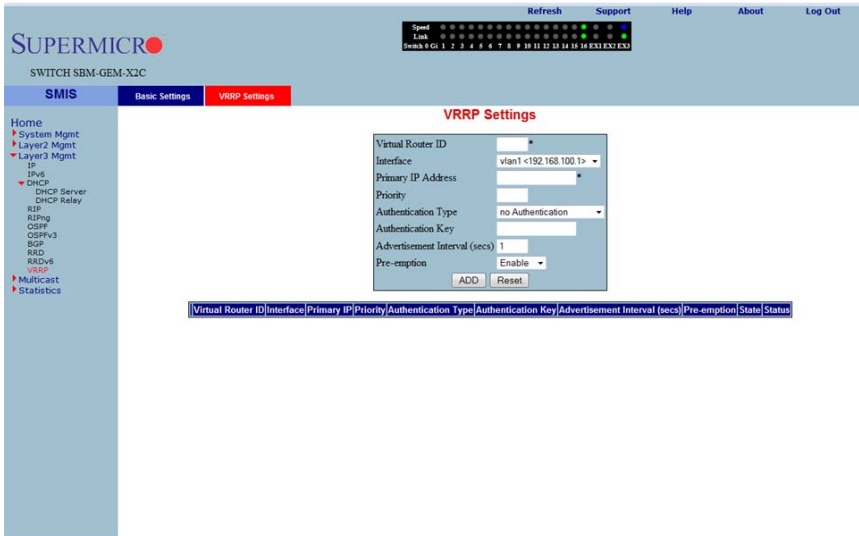

Clicking the VRRP SETTINGS link brings up the VRRP SETTINGS page (Figure 7-146). The parameters for this page are shown in Table 7-117.

Table 7-117. VRRP Settings Page Parameters

Parameter	Description
Virtual Router ID	This parameter indicates the Virtual ID associated with each Virtual Router.
Interface	This parameter represents the interface on which the Virtual Router must be configured.
Primary IP Address	This parameter specifies the PRIMARY IP ADDRESS for the Virtual Router.
Priority	This parameter indicates the PRIORITY for the Virtual Router. The configurable priority value ranges from 1 to 254.
Authentication Type	This parameter indicates the AUTHENTICATION TYPE for the Virtual Router.
Authentication Key	This parameter indicates the AUTHENTICATION KEY for the Virtual Router.
Advertisement Interval (Seconds)	This parameter specifies the time Interval in seconds for sending the advertisement packets.
Preempt Mode	This parameter enables or disables the PREEMPT MODE.
State	This parameter indicates the current state of the Virtual Router.
Status	This parameter specifies the Admin Status of the Virtual Router.

## 7-7 Multicast

Figure 7-147. Multicast Home Page



MULTICAST HOME page (Figure 7-147) has links to multicast features in the switch.

### GMP Snooping

The GMP Snooping link allows you to configure GMP Snooping through the following pages:

- "IGMP Snooping Configuration" on page 7-168
- "IGMP Snooping Timer" on page 7-169
- "IGMP Snooping Interface" on page 7-170
- "IGMP Snooping VLAN Router" on page 7-171
- "IGMP MAC Forwarding" on page 7-172

## IGMP Snooping Configuration

Figure 7-148. IGMP Snooping Configuration Page



Clicking the BASIC SETTINGS tab brings up the IGMP SNOOPING CONFIGURATION page (Figure 7-148), which allows you to configure IGMP snooping parameters. The parameters for this page are shown in Table 7-118.

Table 7-118. IGMP Snooping Configuration Page Parameters

Parameter	Description
System Control	This parameter <i>Starts</i> or <i>Shutdowns</i> IGS in the switch.
IGMP Snooping Status	This parameter enables or disables IGMP snooping globally in the switch. To enable IGS, GMRP status must be <i>Disabled</i> .
Operational Status	This parameter enables or disables IGMP snooping operationally in the switch. To enable IGS, GMRP status must be <i>Disabled</i> .
Proxy Reporting	This parameter indicates whether the proxy reporting in the IGMP snooping switch is to be enabled or disabled.
Snooping Mode	This parameter specifies the IGMP snooping multicast forwarding mode, which can be configured using the Destination IP Address or the Destination MAC Address.
Report Forwarding	This parameter specifies whether the IGMP reports are forwarded on all ports or only on router ports.



Table 7-118. IGMP Snooping Configuration Page Parameters (Continued)

Parameter	Description
Retry Count	This parameter specifies the maximum number of group specific queries sent on a port on the reception of an IGMPv2 leave message.
Query Transmit On TC	This parameter allows you to enable or disable query transmit when topology changes.

## IGMP Snooping Timer

Figure 7-149. IGMP Snooping Timer Configuration Page

The screenshot displays the SUPERMICR web interface for a SWITCH SBM-GEM-X2C. The navigation menu includes Home, System Mgmt, Layer2 Mgmt, Layer3 Mgmt, Multicast, IGMP Snooping, Dynamic Multicast, IGMP, PIM, DVNRP, and Statistics. The 'TIMER' tab is selected, showing the 'IGMP Snooping Timer Configuration' page. The configuration fields are as follows:

Parameter	Value
Router Port Purge Interval (Secs)	125
Group-Member Port Purge Interval (Secs)	260
Report Forward Interval (Secs)	5
Group Query Interval (Secs)	2

Buttons for 'Apply' and 'Reset' are visible at the bottom of the configuration area.

Clicking the TIMER tab brings up the IGMP SNOOPING TIMER CONFIGURATION page (Figure 7-149), which configures IGMP snooping timers. The parameters for this page are shown in Table 7-119.

Table 7-119. IGMP Snooping Timer Configuration Page Parameters

Parameter	Description
Router Port Purge Interval (Secs)	This parameter specifies the interval for which the learnt router port will be purged. The default value is <b>125-seconds</b> .
Group-Member Port Purge Interval (Secs)	This parameter specifies the interval after which a port gets deleted, if IGMP reports are not received on a port. The default value is <b>260-seconds</b> .

**Table 7-119. IGMP Snooping Timer Configuration Page Parameters (Continued)**

Parameter	Description
Report Forward Interval (Secs)	This parameter specifies the interval within which the next report messages for the same multicast group will not be forwarded. The default value is <b>5-seconds</b> .
Group Query Interval (Secs)	This parameter specifies the interval within which the switch sends a group specific query on a port when an IGMPv2 leave message is received. The default value is <b>2-seconds</b> .

**IGMP Snooping Interface**

**Figure 7-150. IGMP Snooping Interface Configuration Page**

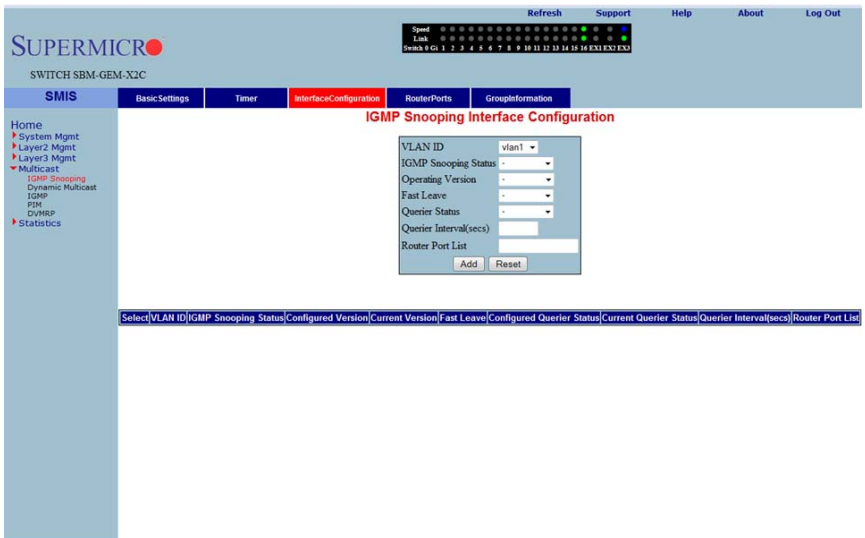

Clicking the INTERFACE CONFIGURATION tab brings up the IGMP SNOOPING INTERFACE CONFIGURATION page (Figure 7-150), which configures IGMP snooping interface specific parameters. The parameters for this page are shown in Table 7-120.

**Table 7-120. IGMP Snooping Interface Configuration Page Parameters**

Parameter	Description
VLAN ID	This parameter specifies the VLAN ID for which the configuration is to be performed.
IGMP Snooping Status	This parameter specifies the status of IGMP snooping in the Switch, which can be enabled or disabled for a specific VLAN.
Operating Version	This parameter specifies the operating version of the IGMP snooping switch for a specific VLAN.

**Table 7-120. IGMP Snooping Interface Configuration Page Parameters (Continued)**

Parameter	Description
Fast Leave	This parameter indicates whether the fast leave processing for a specific VLAN, is to be enabled or disabled.
Querier Status	This parameter specifies whether the IGMP snooping switch is enabled or disabled as a querier for a specific VLAN.
Querier Interval(secs)	This parameter specifies the time period for which general queries are sent by the IGMP snooping switch, when configured as querier on a VLAN.
Router Port List	This parameter specifies the router port list for a specific VLAN.
Current Version	This parameter specifies the working IGMP Version on the given VLAN.
Current Querier Status	This parameter specifies the current status of the Querier.

### IGMP Snooping VLAN Router

**Figure 7-151. IGMP Snooping VLAN Router Ports Page**

The screenshot displays the SUPERMICR web interface for a SWITCH SBM-GEM-X2C. The top navigation bar includes 'Refresh', 'Support', 'Help', 'About', and 'Log Out'. The main navigation tabs are 'Basic Settings', 'Timer', 'Interface Configuration', 'Router Ports', and 'Group Information'. The 'Router Ports' tab is selected, showing the page title 'IGMP Snooping VLAN Router Ports'. A table with two columns, 'VLAN ID' and 'Port List', is visible. The left sidebar contains a navigation menu with options like 'Home', 'System Mgmt', 'Layer2 Mgmt', 'Layer3 Mgmt', 'Multicast', 'IGMP Snooping', 'Dynamic Multicast', 'IGMP', 'PIM', 'DUMRP', and 'Statistics'.

Clicking the ROUTE PORTS tab brings up the IGMP SNOOPING VLAN ROUTER PORTS page (Figure 7-151). The parameters for this page are shown in Table 7-121.

**Table 7-121. IGMP Snooping VLAN Router Ports Page Parameters**

Parameter	Description
VLAN ID	This parameter specifies the VLAN ID.
Port List	This parameter specifies the ports on which routers are connected for a specific VLAN.

**IGMP MAC Forwarding**

**Figure 7-152. MAC Based Multicast Forwarding Table Page**



Clicking the GROUP INFORMATION tab brings up the MAC BASED MULTICAST FORWARDING TABLE page (Figure 7-152), which displays either the IP Based or the MAC Based Multicast Forwarding Table depending upon the configuration of the forwarding mode. The parameters for this page are shown in Table 7-122.

**Table 7-122. MAC Based Multicast Forwarding Table Page Parameters**

Parameter	Description
VLAN ID	This parameter specifies the VLAN ID pertaining to the MAC based multicast forwarding entry.
Group MAC Address	This parameter specifies the Group MAC Multicast address that is learnt.
Port List	This parameter specifies the learnt ports.

## Dynamic Multicast

The Dynamic Multicast link allows you to configure Dynamic Multicast through the following pages:

- "Global Configuration" on page 7-173
- "Dynamic Multicast Port Configuration" on page 7-174

### Global Configuration

Figure 7-153. Dynamic Multicast Global Configuration Page

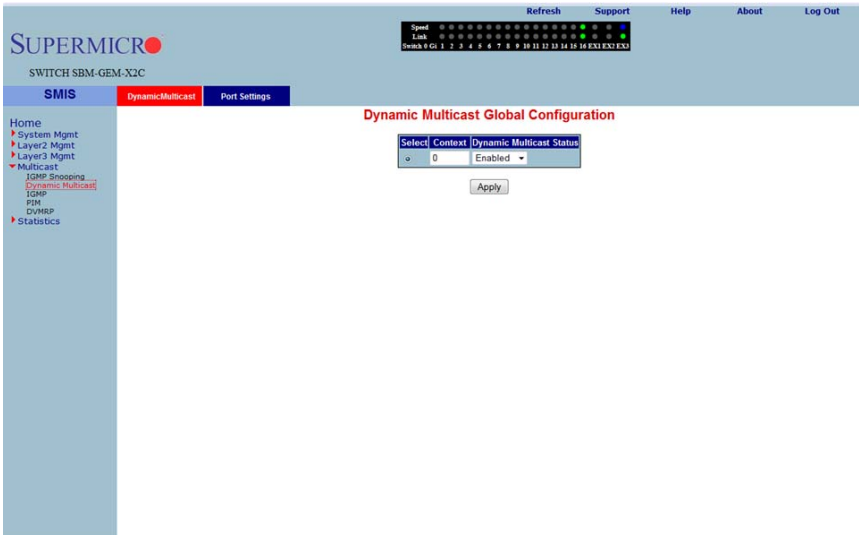

Clicking the DYNAMIC MULTICAST tab brings up the DYNAMIC MULTICAST GLOBAL CONFIGURATION page (Figure 7-153), which allows you to enable or disable the dynamic multicast feature.

## Dynamic Multicast Port Configuration

Figure 7-154. Dynamic Multicast Port Configuration Page

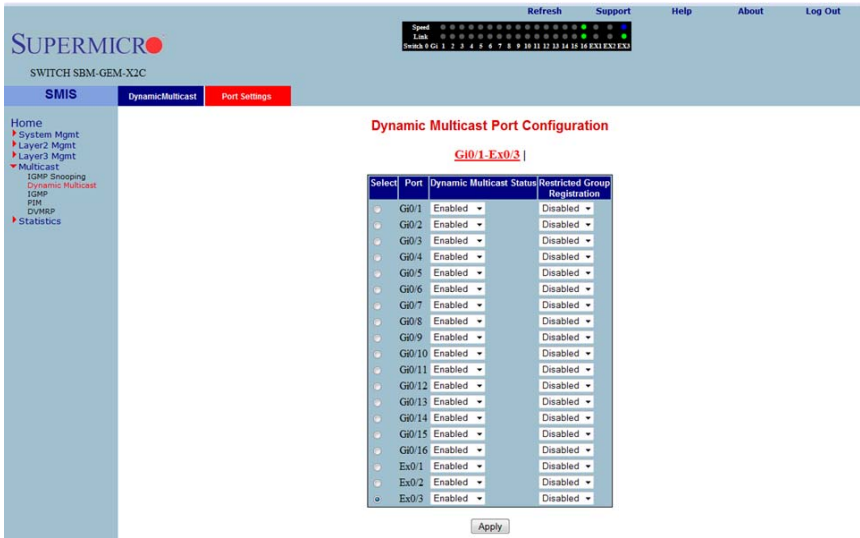

Clicking the PORT SETTINGS tab brings up the DYNAMIC MULTICAST PORT CONFIGURATION page (Figure 7-154), which configures dynamic multicast at the port level. The parameters for this page are shown in Table 7-123.

Table 7-123. Dynamic Multicast Port Configuration Page Parameters

Parameter	Description
Port	This parameter specifies the Port index.
Dynamic Multicast Status	This parameter enables or disables dynamic multicast on this port.
Restricted Group Registration	This parameter enables or disables RESTRICTED GROUP REGISTRATION on this port.

## IGMP

The IGMP page allows you to configure the IGMP protocol. The IGMP protocol in the switch can be configured through the following pages:

- "Basic Settings" on page 7-175
- "Interface Configuration" on page 7-176
- "Group Information" on page 7-177
- "Source Information" on page 7-178

### *Basic Settings*

Figure 7-155. IGMP Configuration Page

The screenshot shows the SUPERMICR web interface for a SWITCH SBM-GEM-X2C. The top navigation bar includes 'Refresh', 'Support', 'Help', 'About', and 'Log Out'. The main navigation menu has tabs for 'Basic Settings', 'Interface Configuration', 'Group Information', and 'Source Information'. The 'IGMP Configuration' page is active, showing a 'Global Status' dropdown menu set to 'Disabled' and 'Apply' and 'Reset' buttons. The left sidebar contains a tree view with 'Home', 'System Mgmt', 'Layer2 Mgmt', 'Layer3 Mgmt', 'Multicast', 'IGMP Snooping', 'Dynamic Multicast', 'IGMP', 'RIP', 'DVNRP', and 'Statistics'.

Clicking the IGMP CONFIGURATION tab brings up the IGMP CONFIGURATION page (Figure 7-155), whose single parameter allows you to enable or disable IGMP in the switch.

## Interface Configuration

Figure 7-156. IGMP Interface Configuration Page

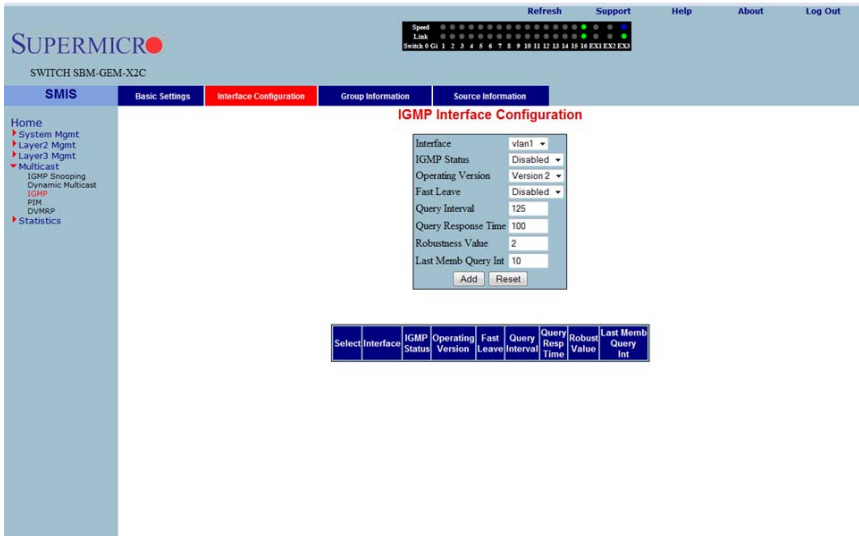

Clicking the INTERFACE CONFIGURATION tab brings up the IGMP INTERFACE CONFIGURATION page (Figure 7-156). The parameters for this page are shown in Table 7-124.

Table 7-124. IGMP Interface Configuration Page Parameters

Parameter	Description
Interface	This parameter specifies the interface index.
IGMP Status	This parameter specifies the IGMP Status.
Operating Version	With this parameter you can choose to run either in <i>IGMP Version 1</i> , <i>IGMP Version 2</i> or <i>IGMP Version 3</i> . This can be configured for every interface.
Fast Leave	This parameter indicates whether the fast leave processing for a specific interface, is to be enabled or disabled.
Query Interval	This parameter indicates the interval between two successive IGMP queries.
Query Response Time	This parameter specifies the response time for IGMP queries.
Robustness Value	This parameter specifies the ROBUSTNESS VALUE on this interface.



## Group Information

Figure 7-157. IGMP Group Configuration Page

Refresh Support Help About Log Out

Speed  
Link  
Switch # Gi 1 2 3 4 5 6 7 8 9 10 11 12 13 14 15 16 EX3 EX3 EX3

SMIS Basic Settings Interface Configuration **Group Information** Source Information

Home  
System Mgmt  
Layer2 Mgmt  
Layer3 Mgmt  
Multicast  
IGMP Snooping  
Dynamic Multicast  
IGMP  
PIM  
DMRP  
Statistics

**IGMP Group Configuration**

Interface vlan1  
Group Address  
Source Address  
Add Reset

Note: Source Address is useful only on IGMP v3 interfaces.

Select | Interface | Group Address | Static | Dynamic | Include | Exclude | Up Time | Expiry Time | Last Reporter

Clicking the GROUP INFORMATION tab brings up the IGMP GROUP CONFIGURATION page (Figure 7-157). The parameters for this page are shown in Table 7-125.

Table 7-125. IGMP Group Configuration Page Parameters

Parameter	Description
Interface	This parameter specifies the interface index.
Group Address	This parameter specifies the IP multicast group address.
Source Address	This parameter represents the IP Source address. <b>NOTE:</b> Source configuration is allowed only when the operating version is v3 on this interface.
Filter Mode	This parameter specifies the FILTER MODE.

## Source Information

Figure 7-158. IGMP Source Information Page

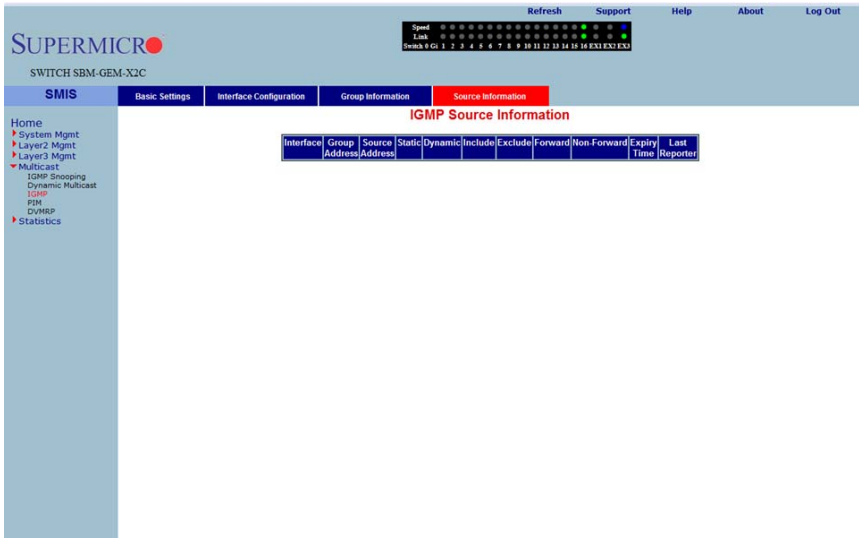

Clicking the SOURCE INFORMATION tab brings up the IGMP SOURCE INFORMATION page (Figure 7-158). The parameters for this page are shown in Table 7-126.

Table 7-126. IGMP Source Information Page Parameters

Parameter	Description
Group Address	This parameter specifies the IP multicast group address.
Interface	This parameter specifies the interface index.
Source Address	This parameter represents the IP Source address.

## PIM

The PIM link allows you to perform PIM related configuration through the following pages:

- "Basic Settings" on page 7-179
- "Component" on page 7-180
- "Interfaces" on page 7-181
- "Candidate RPs" on page 7-182
- "Threshold" on page 7-183
- "Static RP" on page 7-184

### Basic Settings

Figure 7-159. PIM Basic Settings Page

The screenshot displays the 'PIM Basic Settings' page within the SMIS (Switch Management Interface) web application. The interface includes a navigation menu on the left with options like Home, System Mgmt, Layer 2 Mgmt, Layer 3 Mgmt, Multicast, IGMP Snooping, Dynamic Multicast, IGMP, PIM, DVIRP, and Statistics. The main content area is titled 'PIM Basic Settings' and contains the following configuration fields:

- PIM Status: Disabled (dropdown menu)
- PIM V6 Status: Disabled (dropdown menu)
- Registration Stop Rate Limiting Period: 5 seconds (text input)
- PMBR Status: Disabled (dropdown menu)
- Static RP: Disabled (dropdown menu)

An 'Apply' button is located below the configuration fields. A note at the bottom of the page states: "Note : To enable PIM , IGMP Proxy should be disabled."

Clicking the BASIC SETTINGS tab brings up the PIM BASIC SETTINGS page (Figure 7-159), which specifies the PIM status in the switch. The parameters for this page are shown in Table 7-127.

Table 7-127. PIM Basic Settings Page Parameters

Parameter	Description
PIM Status	This parameter allows you to enable or disable the PIM status in the switch.
PIM V6 Status	This parameter allows you to enable or disable the PIM V6 status in the switch.

**Table 7-127. PIM Basic Settings Page Parameters (Continued)**

Parameter	Description
Registration Stop Rate Limiting Period	This parameter specifies the registration stop rate limiting period in seconds.
PMBR Status	This parameter allows you to enable or disable the PMBR status in the switch.
Static RP	This parameter allows you to enable or disable the Static RP in the switch.

**Component**

**Figure 7-160. PIM Component Configuration Page**

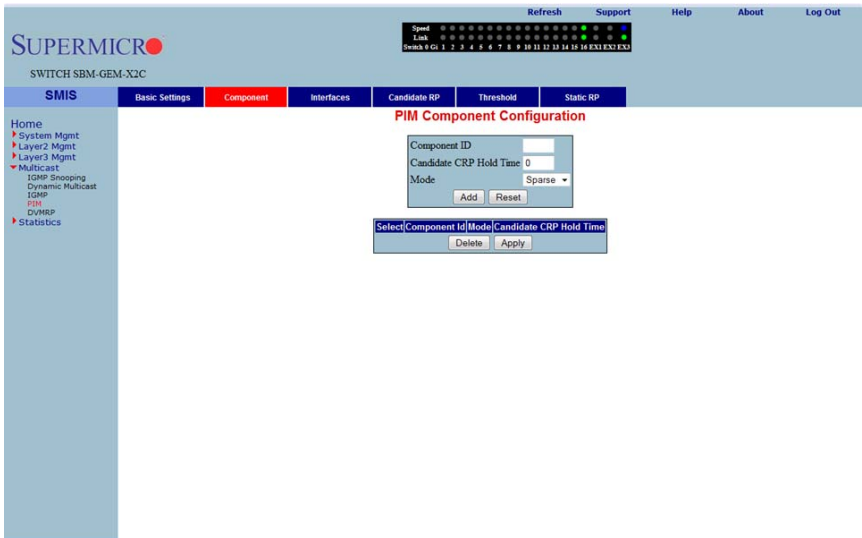

Clicking the COMPONENT tab brings up the PIM COMPONENT CONFIGURATION page (Figure 7-160). The parameters for this page are shown in Table 7-128.

**Table 7-128. PIM Component Configuration Page Parameters**

Parameter	Description
Component ID	This parameter specifies a number uniquely identifying the component.
Candidate CRP Hold Time	This parameter specifies the hold time of the component when it is a candidate RP in the local domain.
Mode	This parameter specifies the mode of the component. It can be <i>Sparse</i> or <i>Dense</i> .

Table 7-128. PIM Component Configuration Page Parameters (Continued)

Parameter	Description
BSR Address	This parameter specifies the IP address of the bootstrap router for the local PIM region, which is a read-only field.
BSR Expiry Time	This parameter indicates the minimum time remaining before the bootstrap router in the local domain is declared down, which is a read-only field.

## Interfaces

Figure 7-161. PIM Interface Configuration Page

The screenshot displays the 'PIM Interface Configuration' page. At the top, there are navigation links: Refresh, Support, Help, About, and Log Out. Below these is a status bar with 'Speed' and 'Link' indicators. The main navigation bar includes 'SMIS', 'Basic Settings', 'Component', 'Interfaces' (highlighted), 'Candidate RP', 'Threshold', and 'Static RP'. A left sidebar contains a menu with 'Home', 'System Mgmt', 'Layer2 Mgmt', 'Layer3 Mgmt', 'Multicast', 'IGMP Snooping', 'Dynamic Multicast', 'IGMP', 'PIM', 'DVNRP', and 'Statistics'. The main content area is titled 'PIM Interface Configuration' and contains a form with the following fields:

- Interface: vlan1
- Address Type: IPv4
- Component ID: 1
- DR Priority: 1
- Hello Hold Time: 105
- Lan Delay: 0
- Override Interval: 0
- Query Interval (secs): 30
- Message Interval (secs): 60
- BSR Candidate Preference: -1
- LAN Prune Delay: Disable

Buttons for 'Add' and 'Reset' are located below the form. At the bottom of the page, there is a toolbar with 'Apply' and 'Delete' buttons, and a row of small icons representing different configuration parameters.

Clicking the INTERFACES tab brings up the PIM INTERFACE CONFIGURATION page (Figure 7-161). The parameters for this page are shown in Table 7-129.

Table 7-129. PIM Interface Configuration Page Parameters

Parameter	Description
Interface	This parameter specifies the interface index.
Component ID	This parameter specifies a number uniquely identifying the component.
Hello Interval (Seconds)	This parameter specifies the time interval between two successive Hello messages being sent by PIM on this interface.
Join Prune Interval (Seconds)	This parameter specifies the time interval between two successive Join/Prune messages being sent by PIM on this interface.

**Table 7-129. PIM Interface Configuration Page Parameters (Continued)**

Parameter	Description
CBSR Preference	This parameter indicates the preference value for the local interface as a candidate bootstrap router.
Row Status	This parameter indicates the operational status of the entry.

**Candidate RPs**

**Figure 7-162. Candidate RP Configuration Page**

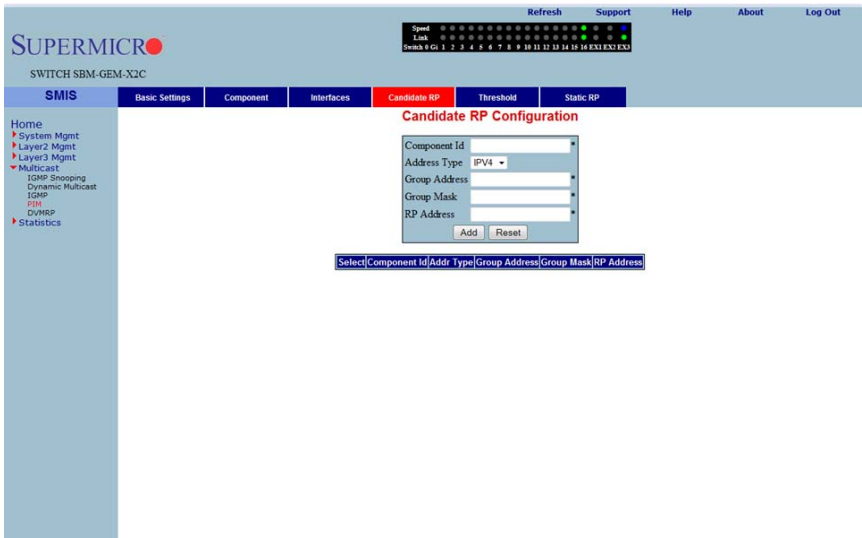

Clicking the CANDIDATE RPs tab brings up the CANDIDATE RP CONFIGURATION page (Figure 7-162). The parameters for this page are shown in Table 7-130.

**Table 7-130. Candidate RP Configuration Page Parameters**

Parameter	Description
Component ID	This parameter specifies a number uniquely identifying the component.
Group Address	This parameter represents the multicast group, for which the switch advertises itself as the candidate RP.
Group Mask	This parameter specifies the subnet mask, which when combined with the group address gives the group prefix.
RP Address	This parameter represents the IP address of the Candidate-RP.

## Threshold

Figure 7-163. PIM Threshold Configuration Page

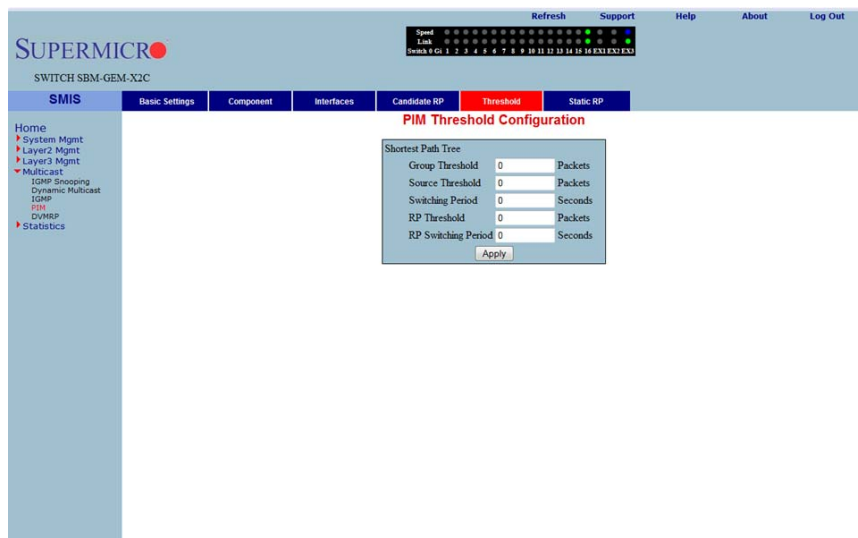

Clicking the THRESHOLD tab brings up the PIM THRESHOLD CONFIGURATION page (Figure 7-163). The parameters for this page are shown in Table 7-131.

Table 7-131. PIM Threshold Configuration Page Parameters

Parameter	Description
Group Threshold	This parameter is a bits-per-second (BPS) value that when it exceeds a certain value, initiates source specific counters for a particular group.
Source Threshold	This parameter is a bits-per-second (BPS) value that when exceeds a certain value, initiates switching to shortest path tree.
Switching Period	This parameter specifies the time interval that the data rate is monitored for, initiating the counters or for switching to SPT.
RP Threshold	When the number of registered packets received exceeds this threshold value, RP initiates switching to SPT.
RP Switching Period	This parameter specifies the time interval for which the registered packets are monitored to initiate switching to SPT.

**Static RP**

**Figure 7-164. Static RP Configuration Page**

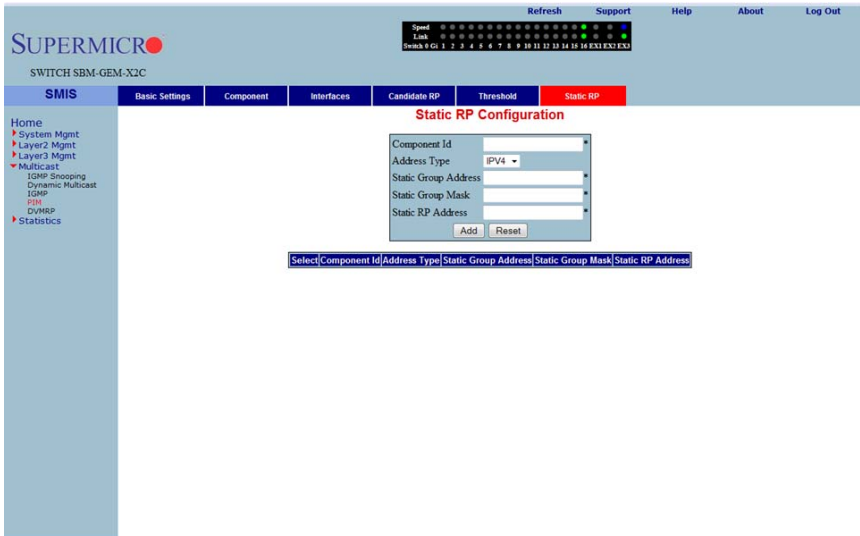

Clicking the STATIC RP tab brings up the STATIC RP CONFIGURATION page (Figure 7-164), which configure static PIM RPs (Rendezvous Points). The parameters for this page are shown in Table 7-132.

**Table 7-132. Static RP Configuration Page Parameters**

Parameter	Description
Component ID	This parameter specifies a number uniquely identifying the component.
Address Type	This parameter chooses the IPv4 or IPv6 address type.
Static Group Address	This parameter represents the multicast group, for which the switch advertises itself as the candidate RP.
Static Group Mask	This parameter specifies the subnet mask, which when combined with the group address gives the group prefix.
Static RP Address	This parameter represents the IP address of the candidate RP.



## DVMRP

The DVMRP page allows you to configure the DVMRP protocol using the following pages:

- "DVMRP Basic Settings" on page 7-185
- "Interfaces" on page 7-186

### DVMRP Basic Settings

Figure 7-165. DVMRP Basic Settings Page

The screenshot shows the SUPERMICR web interface for a SWITCH SBM-GEM-X2C. The navigation menu on the left includes Home, System Mgmt, Layer2 Mgmt, Layer3 Mgmt, Multicast, IGMP Snooping, Dynamic Multicast, IGMP, PIM, DVMRP, and Statistics. The main content area is titled "DVMRP Basic Settings" and contains two configuration fields: "DVMRP Status" set to "Disabled" and "Prune Lifetime (secs)" set to "0". An "Apply" button is located below these fields. A note at the bottom states: "Note : To enable DVMRP , [IGMP Proxy](#) should be disabled."

Clicking the BASIC SETTINGS tab brings up the DVMRP BASIC SETTINGS page (Figure 7-165). The parameters for this page are shown in Table 7-133.

Table 7-133. DVMRP Basic Settings Page Parameters

Parameter	Description
DVMRP Status	DVMRP can be enabled or disabled in the switch using this field.
Prune Lifetime (Seconds)	This parameter represents the Prune Life Time Configuration value.

## Interfaces

Figure 7-166. DVMRP Interface Settings Page

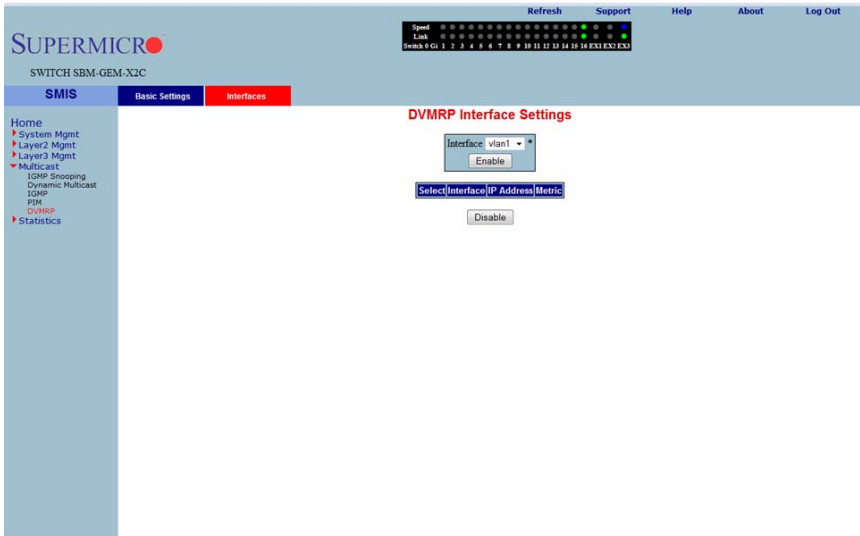

Clicking the INTERFACES tab brings up the DVMRP INTERFACE SETTINGS page (Figure 7-166), which displays the various parameters XXXXXX. The parameters for this page are shown in Table 7-134.

Table 7-134. DVMRP Interface Settings Page Parameters

Parameter	Description
Interface	This parameter specifies the Interface Index.
IP Address	This parameter specifies the IP Address of the interface, which is a read-only field.
Metric	This parameter specifies the distance metric for this interface, which is used to calculate distance vectors.

## 7-8 Statistics

Figure 7-167. Statistics Home Page

The screenshot shows the web interface for a Supermicro switch. At the top, there is a navigation bar with links for Refresh, Support, Help, About, and Log Out. Below this, the SUPERMICRO logo and the model name SWITCH SBM-GEM-X2C are displayed. A status bar shows 'Speed' and 'Link' indicators. The main content area is titled 'Welcome to the Statistics Page' and includes a paragraph: 'The Statistics of the various layer2, layer3 protocols and other information of the Supermicro switch can be viewed through the links available in this page.' Below this text is a list of links, each with a small icon and a description:
 

- [Interface](#): display interface statistics
- [Radius](#): display Radius statistics
- [TACACS+ Server](#): display TACACS+ statistics
- [RMON](#): display RMON statistics
- [SNMP AGENT](#): display SNMP AGENT statistics
- [SNMP AGENTX](#): display SNMP AGENTX statistics
- [VLAN](#): display VLAN statistics
- [RSTP](#): display RSTP statistics
- [MSTP](#): display MSTP statistics
- [LA](#)

 The left sidebar contains a tree view of the switch's configuration options, including System Mgmt, Layer2 Mgmt, Layer3 Mgmt, Multicast, and Statistics (with sub-items like Interface, Radius, TACACS+, RMON, SNMP, VLAN, RSTP, MSTP, LA, 802.1x, IP, IPv6, RIP, RIPv2, RIPv3, OSPF, OSPFv3, VRRP, IGMP, IGMP Snooping, PIM, and DVRRP).

The STATISTICS HOME page (Figure 7-167) contains links to all statistical information for all switch features.

## Interface

The Interface link allows you to configure the following pages:

- "Interface Statistics" on page 7-188
- "Ethernet Statistics" on page 7-189

### Interface Statistics

Figure 7-168. Interface Statistics Page

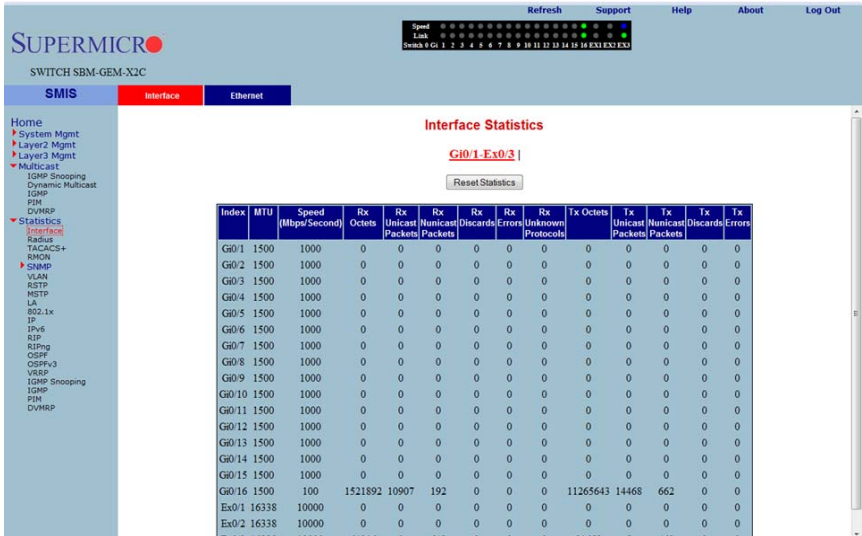

Clicking the INTERFACE tab brings up the INTERFACE STATISTICS page (Figure 7-168). The parameters for this page are shown in Table 7-135.

Table 7-135. Interface Statistics Page Parameters

Parameter	Description
Index	This parameter specifies the Port index.
MTU	This parameter specifies the Max Transfer Unit bytes.
Speed (Bits Per Second)	This parameter specifies the port speed in bits per second.
Received Octets	This parameter specifies the number of bytes received.
Received Unicast Packets	This parameter specifies the number of unicast packets received.
Received Nunicast Packets	This parameter specifies the number of non-unicast packets received.
Received Discards	This parameter specifies the number of packets discarded due to errors.
Received Errors	This parameter specifies the number of packets received with errors.

Table 7-135. Interface Statistics Page Parameters (Continued)

Parameter	Description
Received Unknown Protocols	This parameter specifies the number of packets received with an unknown protocol.
Transmitted Octets	This parameter specifies the number of bytes transmitted.
Transmitted Unicast Packets	This parameter specifies the number of unicast packets transmitted.
Transmitted Multicast Packets	This parameter specifies the number of non-unicast packets transmitted.
Transmitted Discards	This parameter specifies the number of packets discarded due to transmit errors.
Transmitted Errors	This parameter specifies the number of transmit errors.

**Ethernet Statistics**

Figure 7-169. Ethernet Statistics Page

The screenshot shows the 'Ethernet Statistics' page for interface 'G0/1 Ex0/3'. The page includes a navigation menu on the left with 'Ethernet' selected. The main content area displays a table of interface statistics.

Index	Alignment Errors	FCS Errors	Single Collision Frames	Multiple Collision Frames	SQE Test Errors	Deferred Tx	Late Collisions	Excess Collisions	Tx Internal MAC Errors	Carrier Sense Errors	Frame Too Long	Rx Internal MAC Errors	Ether ChipSet	Symbol Errors	Duplex Status
G0/1	0	0	0	0	0	0	0	0	0	0	0	0	1	0	Full-Duplex
G0/2	0	0	0	0	0	0	0	0	0	0	0	0	1	0	Full-Duplex
G0/3	0	0	0	0	0	0	0	0	0	0	0	0	1	0	Full-Duplex
G0/4	0	0	0	0	0	0	0	0	0	0	0	0	1	0	Full-Duplex
G0/5	0	0	0	0	0	0	0	0	0	0	0	0	1	0	Full-Duplex
G0/6	0	0	0	0	0	0	0	0	0	0	0	0	1	0	Full-Duplex
G0/7	0	0	0	0	0	0	0	0	0	0	0	0	1	0	Full-Duplex
G0/8	0	0	0	0	0	0	0	0	0	0	0	0	1	0	Full-Duplex
G0/9	0	0	0	0	0	0	0	0	0	0	0	0	1	0	Full-Duplex
G0/10	0	0	0	0	0	0	0	0	0	0	0	0	1	0	Full-Duplex
G0/11	0	0	0	0	0	0	0	0	0	0	0	0	1	0	Full-Duplex
G0/12	0	0	0	0	0	0	0	0	0	0	0	0	1	0	Full-Duplex
G0/13	0	0	0	0	0	0	0	0	0	0	0	0	1	0	Full-Duplex
G0/14	0	0	0	0	0	0	0	0	0	0	0	0	1	0	Full-Duplex
G0/15	0	0	0	0	0	0	0	0	0	0	0	0	1	0	Half-Duplex
G0/16	0	0	0	0	0	0	0	0	0	0	0	0	1	0	Full-Duplex
Ex0/1	0	0	0	0	0	0	0	0	0	0	0	0	1	0	Full-Duplex
Ex0/2	0	0	0	0	0	0	0	0	0	0	0	0	1	0	Full-Duplex
Ex0/3	0	0	0	0	0	0	0	0	0	0	0	0	1	0	Full-Duplex

Clicking the ETHERNET tab brings up the ETHERNET STATISTICS page (Figure 7-169). The parameters for this page are shown in Table 7-136.

**Table 7-136. Ethernet Statistics Page Parameters**

Parameter	Description
Index	This parameter specifies the port index.
Alignment Errors	This parameter specifies the number of alignment errors. Alignment errors generally indicate improper byte-alignment for Ethernet packets.
FCS Errors	This parameter specifies the number of packets received with checksum errors.
Single Collision Frames	This parameter specifies the number of frames received with a collision.
Multiple Collision Frames	This parameter specifies the number of frames received with multiple collisions.
SQE Test Errors	This parameter specifies the number of Signal Quality Errors that have occurred.
Deferred Transmissions	This parameter specifies the number of frames deferred for transmissions due to network sense.
Late Collisions	This parameter specifies the number of frames faced late collisions. A collision is considered late if the jam occurs after 512 bit-times, or 64 bytes.
Excess Collisions	This parameter specifies the number of excess collisions detected. Excessive Collisions describe the situation where a station has tried 16 times to transmit without success and discards the frame. This means that there is excessive traffic on the network and this must be reduced.
Transmitted Internal MAC Errors	This parameter specifies the number of MAC transmit errors.
Carrier Sense Errors	This parameter specifies the number of carrier sense errors.
Frame Too Long	This parameter specifies the number of too long frames received for transmission.
Received Internal MAC Errors	This parameter specifies the number of MAC received errors.
Symbol Errors	This parameter specifies the number of symbol errors.
Duplex Status	This parameter specifies the current status of duplex.

## Radius

Figure 7-170. Radius Server Statistics Page

The screenshot displays the 'Radius Server Statistics' page. At the top, there is a status bar with 'Speed' and 'Link' indicators, and buttons for 'Refresh', 'Support', 'Help', 'About', and 'Log Out'. Below the status bar is the 'SMIS' navigation menu on the left, listing various system management options. The main content area is titled 'Radius Server Statistics' and contains a table with the following columns:

Index	Radius Server Address	UDP Port Number	Round Trip Time	No of Request Packets	No of Retransmitted Packets	No of Access-Accept Packets	No of Access-Reject Packets	No of Access-Challenge Packets	No of Malformed Access Responses	No of Bad Authenticators	No of Pending Requests	No of Time Outs	No of Unknown Types
-------	-----------------------	-----------------	-----------------	-----------------------	-----------------------------	-----------------------------	-----------------------------	--------------------------------	----------------------------------	--------------------------	------------------------	-----------------	---------------------

Clicking the RADIUS link brings up the RADIUS SERVER STATISTICS page (Figure 7-170). The parameters for this page are shown in Table 7-137.

Table 7-137. Radius Server Statistics Page Parameters

Parameter	Description
Index	This parameter specifies the port index.
Radius Server Address	This parameter specifies the RADIUS SERVER ADDRESS.
UDP Port Number	This parameter specifies the UDP PORT NUMBER.
Round Trip Time	This parameter displays the ROUND TRIP TIME in seconds.
No of Request Packets	This parameter specifies the number of request packets transmitted.
No of Retransmitted Packets	This parameter specifies the number of packets retransmitted.
No of Access-Accept Packets	This parameter specifies the number of accept packets.
No of Access-Reject Packets	This parameter specifies the number of reject packets.
No of Access-Challenge Packets	This parameter specifies the number of challenge packets.

**Table 7-137. Radius Server Statistics Page Parameters (Continued)**

<b>Parameter</b>	<b>Description</b>
No of Malformed Access Responses	This parameter specifies the number of invalid access responses received.
No of Bad Authenticators	This parameter specifies the number of failed authentications.
No of Pending Requests	This parameter specifies the number of currently pending requests.
No of Time Outs	This parameter specifies the number of time outs that have happened.
No of Unknown Types	This parameter specifies the number of unknown types that have been received.



## TACACS+ Statistics

Figure 7-171. TACACS+ Statistics Page

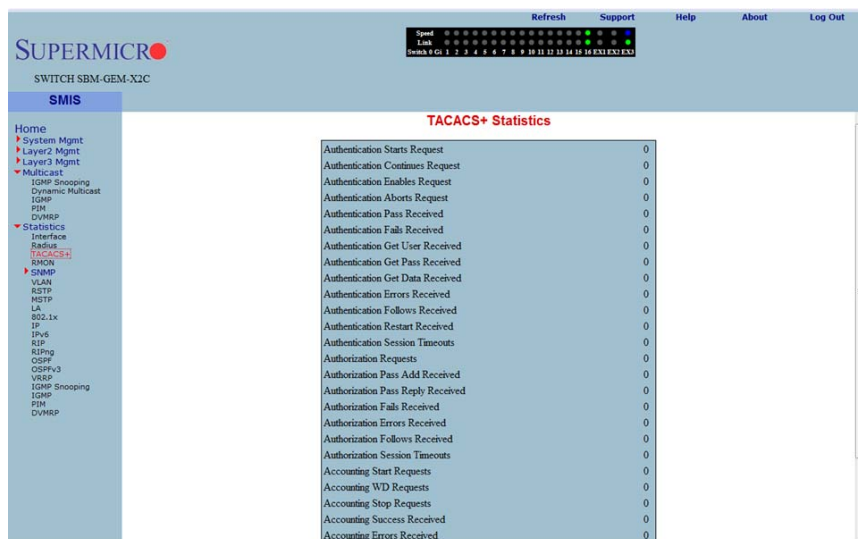

Clicking the TACACS+ link brings up the TACACS+ STATISTICS page (Figure 7-171). The parameters for this page are shown in Table 7-138.

Table 7-138. TACACS+ Statistics Page Parameters

Parameter	Description
Authentication Starts Request	This parameter specifies the number of authentication starts requested.
Authentication Continues Request	This parameter specifies the number of authentication continues requested.
Authentication Enables Request	This parameter specifies the number of authentication enables requested.
Authentication Aborts Request	This parameter specifies the number of authentication aborts requested.
Authentication Pass Received	This parameter specifies the number of authentication passes received.
Authentication Fails Received	This parameter specifies the number of authentication fails received.
Authentication Get User Received	This parameter specifies the number of authentication get users received.
Authentication Get Pass Received	This parameter specifies the number of authentication get passes received.

**Table 7-138. TACACS+ Statistics Page Parameters (Continued)**

Parameter	Description
Authentication Get Data Received	This parameter specifies the number of authentication get datas received.
Authentication Errors Received	This parameter specifies the number of authentication errors received.
Authentication Follows Received	This parameter specifies the number of authentication follows received.
Authentication Restart Received	This parameter specifies the number of authentication restarts received.
Authentication Session Timeouts	This parameter specifies the number of authentication session timeouts received.
Authorization Requests	This parameter specifies the number of authentication requests received.
Authorization Pass Add Received	This parameter specifies the number of authentication pass adds received.
Authorization Pass Reply Received	This parameter specifies the number of authentication pass replies received.
Authorization Fails Received	This parameter specifies the number of authentication fails received.
Authorization Errors Received	This parameter specifies the number of authentication errors received.
Authorization Follows Received	This parameter specifies the number of authentication follows received.
Authorization Session Timeouts	This parameter specifies the number of authentication session timeouts.
Accounting Start Requests	This parameter specifies the number of accounting start requests.
Accounting WD Requests	This parameter specifies the number of accounting WD requests.
Accounting Stop Requests	This parameter specifies the number of accounting stop requests.
Accounting Success Received	This parameter specifies the number of accounting successes received.
Accounting Errors Received	This parameter specifies the number of accounting errors received.
Accounting Follows Received	This parameter specifies the number of accounting follows received.
Accounting Session Timeouts	This parameter specifies the number of accounting sessions received.
Malformed Packets Received	This parameter specifies the number of malformed packets received.
Socket Failures	This parameter specifies the number of socket failures.
Connection Failures	This parameter specifies the number of connection failures.

## RMON Ethernet Statistics

Figure 7-172. RMON Ethernet Statistics Page

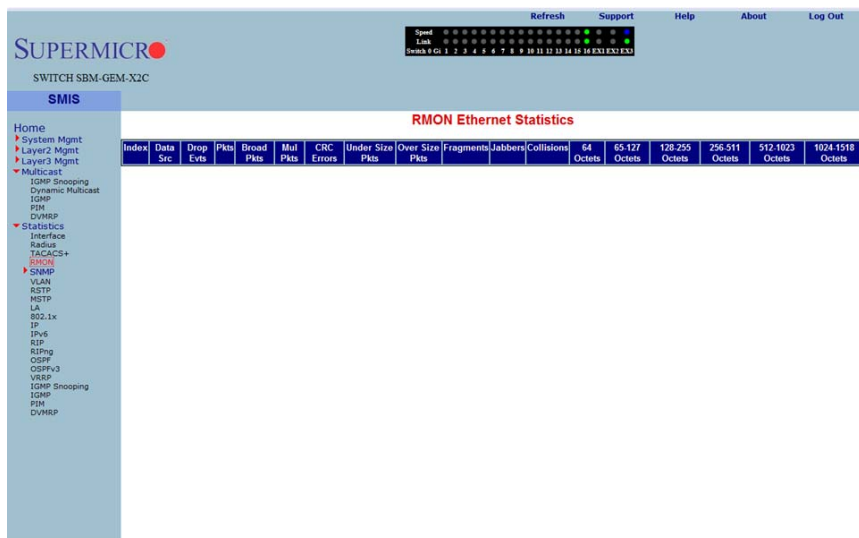

Clicking the RMON link brings up the RMON ETHERNET STATISTICS page (Figure 7-172), which displays RMON Ethernet statistics information. The parameters for this page are shown in Table 7-139.

Table 7-139. RMON Ethernet Statistics Page Parameters

Parameter	Description
Index	This parameter specifies the index.
Port	This parameter specifies the port.
Octets	This parameter specifies the number of octets received.
Packets	This parameter specifies the number of packets received.
Broadcast Packets	This parameter specifies the number of broadcast packets received.
Multicast Packets	This parameter specifies the number of multicast packets received.
CRC Errors	This parameter specifies the number of packets received with crc errors.
Under Size Packets	This parameter specifies the number of under size packets received.
Over Size Packtes	This parameter specifies the number of over size packets received.
Fragments	This parameter specifies the number of fragments received.
Jabbers	This parameter specifies the number of jabbers.
Collisions	This parameter specifies the number of collisions.

**Table 7-139. RMON Ethernet Statistics Page Parameters (Continued)**

<b>Parameter</b>	<b>Description</b>
64 Octets	This parameter specifies the number of Ethernet packets received with a size less than 64 bytes.
65-127 Octets	This parameter specifies the number of Ethernet packets received with a size between 65 and 127 bytes.
128-255 Octets	This parameter specifies the number of Ethernet packets received with a size between 128 and 255 bytes.
256-511 Octets	This parameter specifies the number of Ethernet packets received with a size between 256 and 511 bytes.
512-1023 Octets	This parameter specifies the number of Ethernet packets received with a size between 512 and 1023 bytes.
1024-1518 Octets	This parameter specifies the number of Ethernet packets received with a size between 1024 and 1518 bytes.

## SNMP Statistics

The SNMP Statistics link allows you to configure SNMP Statistics through the following pages:

- "Agent" on page 7-197
- "SNMP AgentX" on page 7-198

### Agent

Figure 7-173. SNMP Statistics Page

The screenshot shows the web interface of a Supermicro switch (SWITCH SBM-GEM-X2C). The left sidebar contains a navigation menu with 'SNMP' expanded to 'AGENTX'. The main content area is titled 'SNMP Statistics' and displays a table with the following data:

SNMP Statistics	
SNMP Packets Input	0
BAD SNMP Version Errors	0
SNMP Unknown Community Name	0
SNMP Get Request PDU's	0
SNMP Get Next PDU's	0
SNMP Set Request PDU's	0
SNMP Packet Output	0
SNMP Too Big Errors	0
SNMP No Such Name Errors	0
SNMP Bad Value Errors	0
SNMP General Errors	0
SNMP Trap PDU's	0
SNMP Manager-Role Output Packets	0
SNMP Inform Responses Received	0
SNMP Inform Request Generated	0
SNMP Inform Messages Dropped	0
SNMP Inform Requests awaiting Acknowledgment	0

Clicking the SNMP AGENT link brings up the SNMP STATISTICS page (Figure 7-173), which displays SNMP statistics. The parameters for this page are shown in Table 7-140.

Table 7-140. SNMP Statistics Page Parameters

Parameter	Description
SNMP Packets Input	This parameter specifies the number of SNMP packets input.
BAD SNMP Version Errors	This parameter specifies the number of BAD SNMP version errors.
SNMP Unknown Community Name	This parameter specifies the number of SNMP unknown community names.
SNMP Get Request PDU's	This parameter specifies the number of SNMP Get Request PDU's.
SNMP Get Next PDU's	This parameter specifies the number of SNMP Get Next PDU's.
SNMP Set Request PDU's	This parameter specifies the number of SNMP Set Request PDU's.

**Table 7-140. SNMP Statistics Page Parameters (Continued)**

Parameter	Description
SNMP Packet Output	This parameter specifies the number of SNMP packets output.
SNMP Too Big Errors	This parameter specifies the number of SNMP Too Big errors,
SNMP No Such Name Errors	This parameter specifies the number of SNMP No Such Name errors,
SNMP Bad Value Errors	This parameter specifies the number of SNMP Bad Value errors.
SNMP General Errors	This parameter specifies the number of SNMP General errors.
SNMP Trap PDU's	This parameter specifies the number of SNMP Trap PDU's.
SNMP Manager-Role Output Packets	This parameter specifies the number of SNMP Manager-Role Output packets.
SNMP Inform Responses Received	This parameter specifies the number of SNMP Inform responses received.
SNMP Inform Request Generated	This parameter specifies the number of SNMP Inform requests generated.
SNMP Inform Messages Dropped	This parameter specifies the number of SNMP Inform messages dropped.
SNMP Inform Requests awaiting Acknowledgement	This parameter specifies the number of SNMP Inform requests awaiting acknowledgement.

***SNMP AgentX***

Clicking the AGENTX link brings up the AGENTX SUBAGENT STATISTICS page (not shown), which displays Agentx Subagent information. The parameters for this page are shown in [Table 7-141](#).

**Table 7-141. Agentx Subagent Statistics Page Parameters**

Parameter	Description
<b>Transmit Statistics</b>	
Transmitted Packets	This parameter specifies the number of packets transmitted.
Open PDU	This parameter specifies the number of open PDUs transmitted.
IndexAlloc PDU	This parameter specifies the number of IndexAlloc PDUs transmitted.
Register PDU	This parameter specifies the number of register PDUs transmitted.
Add Agent Caps PDU	This parameter specifies the number of add agent caps PDUs transmitted.
Notify PDU	This parameter specifies the number of notify PDUs transmitted.
Ping PDU	This parameter specifies the number of ping PDUs transmitted.
Remove Agent Caps PDU	This parameter specifies the number of remove agent caps PDUs transmitted.
IndexDeAlloc PDU	This parameter specifies the number of IndexDeAlloc PDUs transmitted.

**Table 7-141. Agentx Subagent Statistics Page Parameters (Continued)**

Parameter	Description
UnRegister PDU	This parameter specifies the number of unregister PDUs transmitted.
Close PDU	This parameter specifies the number of close PDUs transmitted.
Response PDU	This parameter specifies the number of response PDUs transmitted.
<b>Receive Statistics</b>	
Received Packets	This parameter specifies the number of packets received.
Get Request PDU	This parameter specifies the number of get request PDUs received.
Get Next PDU	This parameter specifies the number of get next PDUs received.
Get Bulk PDU	This parameter specifies the number of get bulk PDUs received.
TestSet PDU	This parameter specifies the number of test set PDUs received.
Commit PDU	This parameter specifies the number of commit PDUs received.
Cleanup PDU	This parameter specifies the number of cleanup PDUs received.
Undo PDU	This parameter specifies the number of undo PDUs received.
Dropped Packets	This parameter specifies the number of dropped packets.
Parse Drop Errors	This parameter specifies the number of received PDUs dropped due to parse errors.
Open Fail Errors	This parameter specifies the number of open fail PDUs received.
Close PDU	This parameter specifies the number of close PDUs received.
Response PDU	This parameter specifies the number of response PDUs received.

## VLAN

The VLAN link allows you to view VLAN statistics through the following pages:

- ["Current DB" on page 7-200](#)
- ["VLAN Port Statistics" on page 7-201](#)
- ["VLAN Multicast Table" on page 7-202](#)
- ["VLAN Counter Statistics" on page 7-203](#)
- ["VLAN Capabilities" on page 7-204](#)
- ["VLAN FDB Entries" on page 7-205](#)

**Current DB**

**Figure 7-174. VLAN Current Database Page**

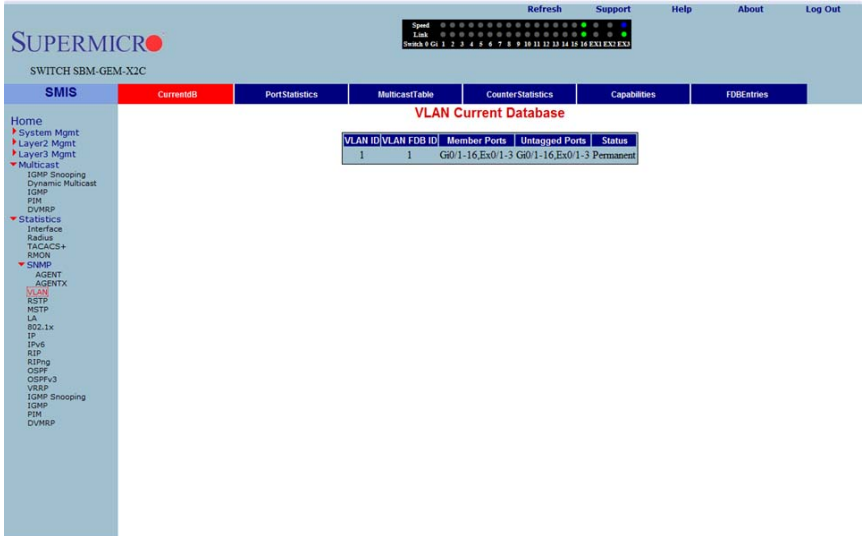

Clicking the CURRENT DB tab brings up the VLAN CURRENT DATABASE page (Figure 7-174), which displays VLAN database entries. The parameters for this page are shown in Table 7-142.

**Table 7-142. VLAN Current Database Page Parameters**

Parameter	Description
VLAN ID	This parameter specifies the VLAN identifier.
VLAN FDB ID	This parameter specifies the VLAN filter database identifier.
Member Ports	This parameter specifies the index of member ports.
Untagged Ports	This parameter specifies the index of untagged member ports.
Status	This parameter specifies the VALN status.



## VLAN Port Statistics

Figure 7-175. VLAN Port Statistics Page

The screenshot shows the SUPERMICR SWITCH SBM-GEM-X2C web interface. The top navigation bar includes 'Refresh', 'Support', 'Help', 'About', and 'Log Out'. Below the navigation bar, there are tabs for 'SMIS', 'CurrentDB', 'PortStatistics', 'MulticastTable', 'CounterStatistics', 'Capabilities', and 'FDBEntries'. The 'PortStatistics' tab is selected, displaying the 'VLAN Port Statistics' page. A table shows the following data:

Port	VLAN ID	Received Frames	Transmitted Frames	Received Discards	Received Overflow	Transmitted Overflow	Transmitted Overflow Discards
Gi0/1	1	0	0	0	0	0	0
Gi0/2	1	0	0	0	0	0	0
Gi0/3	1	0	0	0	0	0	0
Gi0/4	1	0	0	0	0	0	0
Gi0/5	1	0	0	0	0	0	0
Gi0/6	1	0	0	0	0	0	0
Gi0/7	1	0	0	0	0	0	0
Gi0/8	1	0	0	0	0	0	0
Gi0/9	1	0	0	0	0	0	0
Gi0/10	1	0	0	0	0	0	0
Gi0/11	1	0	0	0	0	0	0
Gi0/12	1	0	0	0	0	0	0
Gi0/13	1	0	0	0	0	0	0
Gi0/14	1	0	0	0	0	0	0
Gi0/15	1	0	0	0	0	0	0
Gi0/16	1	0	0	0	0	0	0
Ex0/1	1	0	0	0	0	0	0
Ex0/2	1	0	0	0	0	0	0
Ex0/3	1	0	0	0	0	0	0

Clicking the PORT STATISTICS tab brings up the VLAN PORT STATISTICS page (Figure 7-175), which displays the various parameters XXXXXX. The parameters for this page are shown in Table 7-143.

Table 7-143. VLAN Port Statistics Page Parameters

Parameter	Description
Port	This parameter specifies the port index.
VLAN ID	This parameter specifies the VLAN identifier.
Received Frames	This parameter specifies the number of packets received in this VLAN.
Transmitted Frames	This parameter specifies the number of packets transmitted in this VLAN.
Received Discards	This parameter specifies the number of received packets discarded.
Received Overflow	This parameter specifies the number of received overflow packets.
Transmitted Overflow	This parameter specifies the number of transmit overflows.
Transmitted Overflow Discards	This parameter specifies the number of transmit overflow discards.

## VLAN Multicast Table

Figure 7-176. VLAN Multicast Table Page



Clicking the MULTICAST TABLE tab brings up the VLAN MULTICAST TABLE page (Figure 7-176), which displays multicast VLAN information. The parameters for this page are shown in Table 7-144.

Table 7-144. VLAN Multicast Table Page Parameters

Parameter	Description
VLAN ID	This parameter specifies the VLAN identifier.
Address	This parameter specifies the VLAN address.
Egress Ports	This parameter specifies the indexes of egress ports.
Ports Learnt	This parameter specifies the indexes of ports on this VLAN that are learned.

## VLAN Counter Statistics

Figure 7-177. VLAN Counter Statistics Page

The screenshot shows the SUPERMICR switch management interface. The top navigation bar includes 'SMIS', 'CurrentDB', 'PortStatistics', 'MulticastTable', 'Counter Statistics' (highlighted in red), 'Capabilities', and 'FDBEntries'. The main content area is titled 'VLAN Counter Statistics' and contains a 'Reset Statistics' button and a table with the following data:

Context	VLAN ID	Unicast Frames Rx	Mcast/Bcast Frames Rx	Unknown Unicast Flooded	Unicast frames Tx	Broadcast frames Tx
0						

Clicking the COUNTER STATISTICS link brings up the VLAN COUNTER STATISTICS page (Figure 7-177), which displays VLAN counters. The parameters for this page are shown in Table 7-145.

Table 7-145. VLAN Counter Statistics Page Parameters

Parameter	Description
VLAN ID	This parameter specifies the VLAN identifier.
Unicast Frames Rx	This parameter specifies the number of unicast packets received.
Mcast/Bcast Frames Rx	This parameter specifies the number of non-unicast packets received.
Unknown Unicast Flooded	This parameter specifies the number of packets flooded due to unknown unicast.
Unicast frames Tx	This parameter specifies the number of unicast packets transmitted.
Broadcast frames Tx	This parameter specifies the number of broadcast packets transmitted.

## VLAN Capabilities

Figure 7-178. VLAN Capabilities Page



Clicking the CAPABILITIES tab brings up the VLAN CAPABILITIES page (Figure 7-178), which displays the VLAN capabilities of the switch. The parameters for this page are shown in Table 7-146.

Table 7-146. VLAN Capabilities Page Parameters

Parameter	Description
Extended Filtering Services	This parameter specifies the number of extended filtering services.
Traffic Classes	This parameter specifies the number of traffic classes
Static Entry Individual port	This parameter specifies the number of Static Entry Individual ports.
IVL capable	This parameter specifies the number of IVL capables.
SVL capable	This parameter specifies the number of SVL capables.
Hybrid capable	This parameter specifies the number of Hybrid capables.
Configurable PVID Tagging	This parameter specifies the number of Configurable PVID taggings.

## VLAN FDB Entries

Figure 7-179. VLAN FDB Entries Page

The screenshot shows the SUPERMICR SWITCH SBM-GEM-X2C web interface. The top navigation bar includes 'Refresh', 'Support', 'Help', 'About', and 'Log Out'. Below the navigation bar, there are tabs for 'SMIS', 'CurrentDB', 'PortStatistics', 'MulticastTable', 'CounterStatistics', 'Capabilities', and 'FDB Entries'. The 'FDB Entries' tab is selected. The main content area is titled 'VLAN FDB Entries' and contains a search form with fields for 'VLAN ID', 'MAC Address', 'Port', and 'All'. Below the search form is a table with the following data:

VLAN ID	MAC Address	Port	Status
1	00:1e:cccc:9a:14:16	16	Learned
1	00:30:48:90:00:a:27	27	Learned

Clicking the FDB ENTRIES tab brings up the VLAN FDB ENTRIES page (Figure 7-179), which displays VLAN filter database entries. The parameters for this page are shown in Table 7-147.

Table 7-147. VLAN FDB Entries Page Parameters

Parameter	Description
VLAN ID	This parameter specifies the VLAN identifier.
MAC Address	This parameter specifies the MAC address learned.
Port	This parameter specifies the Index of port where this entry is learned.
Status	This parameter specifies the Status of this entry.

## RSTP Statistics

The RSTP STATISTICS link allows you to view RSTP statistics through the following pages:

- "RSTP Information" on page 7-206
- "RSTP Port Statistics" on page 7-207

### RSTP Information

Figure 7-180. RSTP Information Page

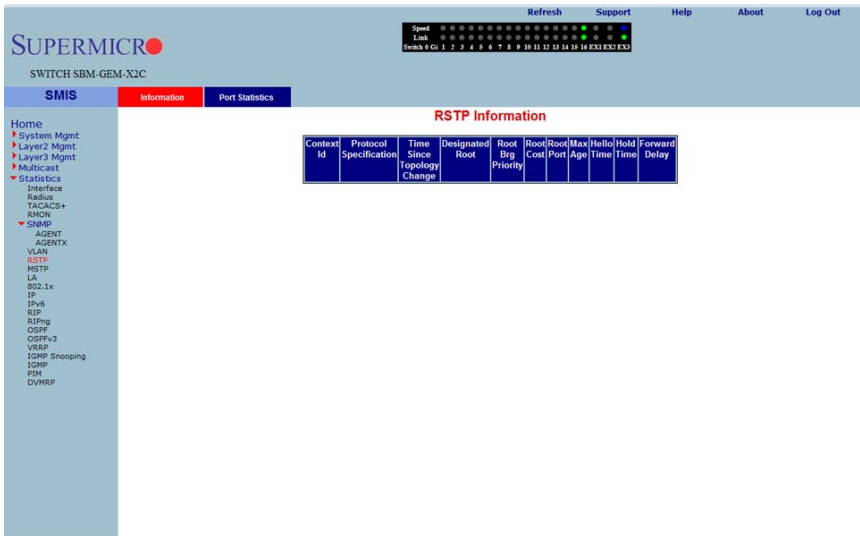

Clicking the INFORMATION tab brings up the RSTP INFORMATION page (Figure 7-180), which displays RSTP statistics. The parameters for this page are shown in Table 7-148.

Table 7-148. RSTP Information Page Parameters

Parameter	Description
Protocol Specification	This parameter specifies the Protocol Specification.
Time Since Topology Change	This parameter specifies the number of seconds since topology changed.
Designated Root	This parameter specifies the designated root bridge address.
Root Brg Priority	This parameter specifies the priority of root bridge.
Root Cost	This parameter specifies the cost to root.
Root Port	This parameter specifies the index of the root port.

Table 7-148. RSTP Information Page Parameters (Continued)

Parameter	Description
Max Age	This parameter specifies the max age in seconds.
Hello Time	This parameter specifies the Hello time in seconds.
Hold Time	This parameter specifies the hold time in seconds.
Forward Delay	This parameter specifies the forward delay in seconds.

### RSTP Port Statistics

Figure 7-181. RSTP Port Statistics Page

The screenshot shows the RSTP Port Statistics page. The table below represents the data shown in the interface:

Port	Received RST BPDUs	Received Configuration BPDUs	Received TCN	Transmitted RST BPDUs	Transmitted Configuration BPDUs	Transmitted TCN	Received Invalid RST BPDUs	Received Invalid Configuration BPDUs	Received Invalid TCN	Protocol Migration Count	Effective Port State	EdgePort Oper Status	Link Type
Gi0/1-Ex0/3													

Clicking the PORT STATISTICS tab brings up the RSTP PORT STATISTICS page (Figure 7-181), which displays RSTP port level statistics. The parameters for this page are shown in Table 7-149.

Table 7-149. RSTP Port Statistics Page Parameters

Parameter	Description
Port	This parameter specifies the port index.
Received RST BPDUs	This parameter specifies the number of RSTP BPDUs received.
Received Configuration BPDUs	This parameter specifies the number of config BPDUs received.
Received TCN	This parameter specifies the number of topology changed notifications received.

**Table 7-149. RSTP Port Statistics Page Parameters (Continued)**

<b>Parameter</b>	<b>Description</b>
Transmitted RST BPDUs	This parameter specifies the number of RSTP BPDUs transmitted.
Transmitted Configuration BPDUs	This parameter specifies the number of config BPDUs transmitted.
Transmitted TCN	This parameter specifies the number of topology change notifications transmitted.
Received Invalid RST BPDUs	This parameter specifies the number of invalid RSTP BPDUs received.
Received Invalid Configuration BPDUs	This parameter specifies the number of invalid configuration BPDUs received.
Received Invalid TCN BPDUs	This parameter specifies the number of invalid topology change BPDUs received.
Protocol Migration Count	This parameter specifies the number of times protocol migration happened.
Effective Port State	This parameter specifies the effective port state.
EdgePort Oper Status	This parameter specifies the operational status of edge port.
Link Type	This parameter specifies the broadcast or point-to-point.



## MSTP Statistics

The MSTP Statistics link allows you to view MSTP statistics through the following pages:

- "MSTP Information" on page 7-209
- "MSTP CIST Statistics" on page 7-210
- "MSTP MSTI Port Statistics" on page 7-211

### MSTP Information

Figure 7-182. MSTP Information Page

The screenshot shows the SUPERMICR web interface for a SWITCH SBM-GEM-X2C. The 'MSTP Information' page is active, displaying a table with the following data:

Context Id	Bridge Address	CIST Root	Regional Root	CIST Root Cost	Reg Root Cost	Root Port	Hold Time	Max Age	Forward Delay	CIST Time Since Topology Change	Topology Changes
0	00:30:48:a3:00:03	80:00:00:30:48:90:00:e2	80:00:00:30:48:a3:00:03	200000000	0	27	1	20	15	0	1

Clicking the INFORMATION tab brings up the MSTP INFORMATION page (Figure 7-138), which displays MSTP statistics. The parameters for this page are shown in Table 7-13.

Table 7-150. MSTP Information Page Parameters

Parameter	Description
Bridge Address	This parameter specifies the Bridge Address.
CIST Root	This parameter specifies the CIST root.
Regional Root	This parameter specifies the Regional root.
CIST Root Cost	This parameter specifies the CIST root cost.
Regional Root Cost	This parameter specifies the Regional root cost.
Root Port	This parameter specifies the index of the root port.
Hold Time	This parameter specifies the hold time in seconds.

Table 7-150. MSTP Information Page Parameters (Continued)

Parameter	Description
Max Age	This parameter specifies the maximum age in seconds.
Forward Delay	This parameter specifies the forward delay in seconds.
CIST Time Since Topology Change	This parameter specifies the number of seconds since topology last changed.
Topology Changes	This parameter specifies the number of topology changes.

**MSTP CIST Statistics**

Figure 7-183. MSTP CIST Port Statistics Page

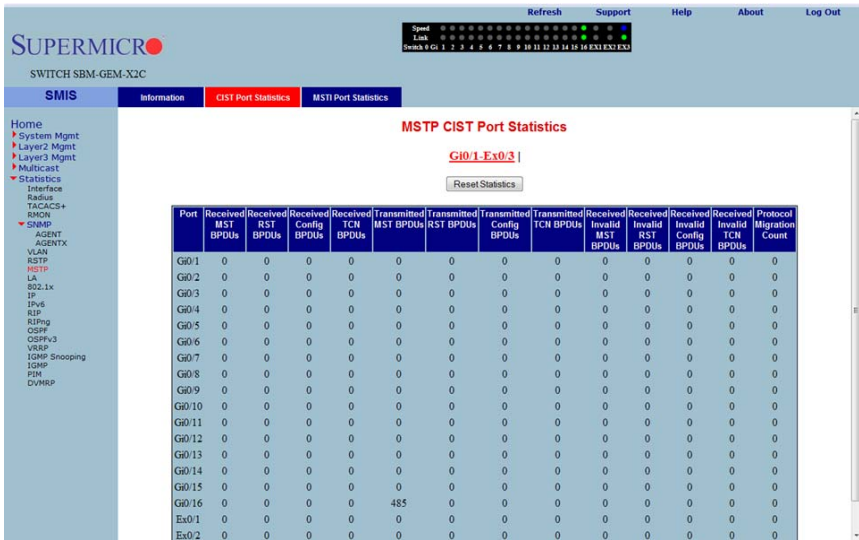

Clicking the CIST PORT STATISTICS tab brings up the MSTP CIST PORT STATISTICS page (Figure 7-183), which displays STP CIST port level statistics. The parameters for this page are shown in Table 7-151.

Table 7-151. MSTP CIST Port Statistics Page Parameters

Parameter	Description
Received MST BPDUs	This parameter specifies the number of MSTP BPDUs received.
Received RST BPDUs	This parameter specifies the number of RSTP BPDUs received.
Received Config BPDUs	This parameter specifies the number of config BPDUs received.
Received TCN BPDUs	This parameter specifies the number of topology change notification BPDUs received.

Table 7-151. MSTP CIST Port Statistics Page Parameters (Continued)

Parameter	Description
Transmitted MST BPDUs	This parameter specifies the number of MSTP BPDUs transmitted.
Transmitted RST BPDUs	This parameter specifies the number of RSTP BPDUs transmitted.
Transmitted Config BPDUs	This parameter specifies the number of config BPDUs transmitted.
Transmitted TCN BPDUs	This parameter specifies the number of topology change notification BPDUs transmitted.
Received Invalid MST BPDUs	This parameter specifies the number of invalid MSTP BPDUs received.
Received Invalid RST BPDUs	This parameter specifies the number of invalid RSTP BPDUs received.
Received Invalid Config BPDUs	This parameter specifies the number of invalid config BPDUs received.
Received Invalid TCN BPDUs	This parameter specifies the number of invalid TCN BPDUs received.
Protocol Migration Count	This parameter specifies the number of times protocol migration happened.

### MSTP MSTI Port Statistics

Figure 7-184. MSTP MSTI Port Statistics Page

The screenshot shows the SUPERMICR SWITCH SBM-GEM-X2C web interface. The top navigation bar includes 'Refresh', 'Support', 'Help', 'About', and 'Log Out'. The left sidebar shows a tree view with 'SMIS' selected, and 'MSTI Port Statistics' highlighted in red. The main content area displays the 'MSTP MSTI Port Statistics' page with a table header:

Instance	Port	Designated Root	Designated Bridge	Designated Port	State	Forward Transitions	Received BPDUs	Transmitted BPDUs	Invalid Received BPDUs	Designated Cost	Role

Clicking the MSTI PORT STATISTICS tab brings up the MSTP MSTI PORT STATISTICS page (Figure 7-184), which displays MSTP MSTI port level statistics. The parameters for this page are shown in Table 7-152.

**Table 7-152. MSTP MSTI Port Statistics Page Parameters**

Parameter	Description
Instance	This parameter specifies the MSTP instance Identifier.
Port	This parameter specifies the port index.
Designated Root	This parameter specifies the designated root bridge address.
Designated Bridge	This parameter specifies the designated Bridge address.
Designated Port	This parameter specifies the index of designated port for this MSTP instance.
State	This parameter specifies the current state.
Forward Transitions	This parameter specifies the number of Forward Transitions.
Received BPDUs	This parameter specifies the number of BPDUs received.
Transmitted BPDUs	This parameter specifies the number of BPDUs transmitted.
Invalid Received BPDUs	This parameter specifies the number of invalid BPDUs received.
Designated Cost	This parameter specifies the designated cost.
Role	This parameter specifies the current role.

### **Link Aggregation (LA)**

The Link Aggregation link allows you to view Link Aggregation (LA) statistics through the following pages:

- ["LA Port Statistics" on page 7-213](#)
- ["LA Neighbor Statistics" on page 7-214](#)

## LA Port Statistics

Figure 7-185. LA Port Statistics Page

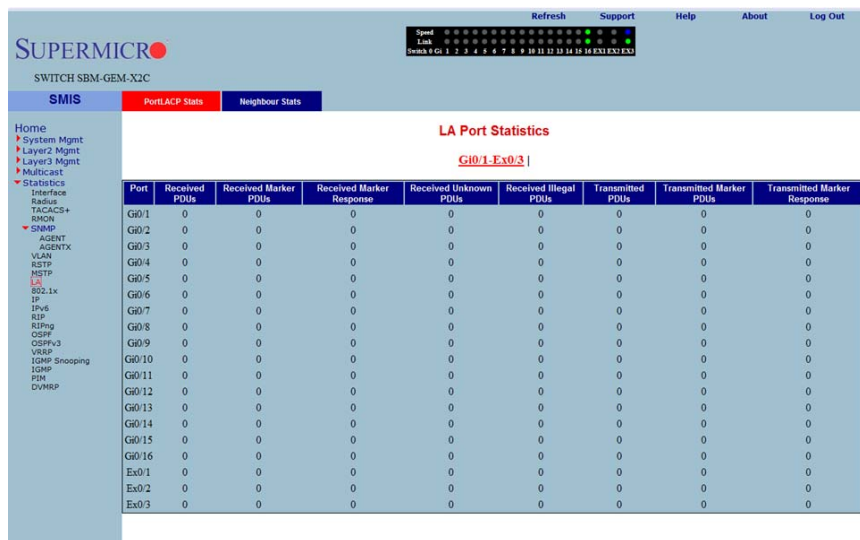

Clicking the PORT LACP STATS tab brings up the LA PORT STATISTICS page (Figure 7-185), which displays LACP port level statistics. The parameters for this page are shown in Table 7-153.

Table 7-153. LA Port Statistics Page Parameters

Parameter	Description
Port	This parameter specifies the port index.
Received PDUs	This parameter specifies the number of LACP PDUs received.
Received Marker PDUs	This parameter specifies the number of Marker PDUs received.
Received Marker Response	This parameter specifies the number of Marker response PDUs received.
Received Unknown PDUs	This parameter specifies the number of unknown PDUs received.
Received Illegal PDUs	This parameter specifies the number of invalid PDUs received.
Transmitted PDUs	This parameter specifies the number of LACP PDUs transmitted.
Transmitted Marker PDUs	This parameter specifies the number of Marker PDUs transmitted.
Transmitted Marker Response	This parameter specifies the number of Marker response PDUs transmitted.

## LA Neighbor Statistics

Figure 7-186. LA Neighbor Statistics Information Page

The screenshot shows a network management interface. At the top, there is a status bar with 'SUPERMICR' and 'SWITCH SBM-GEM-X2C'. Below this, there are navigation tabs: 'SMIS', 'PortLACP Stats', and 'Neighbour Stats'. The 'Neighbour Stats' tab is selected. The main content area is titled 'LA Neighbour Statistics Information' and shows a sub-header 'Gi0/1-Ex0/3'. Below this is a table with the following data:

Port	Partner SystemID	Oper Key	Partner Port Priority
Gi0/1	00.00.00.00.00.00	0	0
Gi0/2	00.00.00.00.00.00	0	0
Gi0/3	00.00.00.00.00.00	0	0
Gi0/4	00.00.00.00.00.00	0	0
Gi0/5	00.00.00.00.00.00	0	0
Gi0/6	00.00.00.00.00.00	0	0
Gi0/7	00.00.00.00.00.00	0	0
Gi0/8	00.00.00.00.00.00	0	0
Gi0/9	00.00.00.00.00.00	0	0
Gi0/10	00.00.00.00.00.00	0	0
Gi0/11	00.00.00.00.00.00	0	0
Gi0/12	00.00.00.00.00.00	0	0
Gi0/13	00.00.00.00.00.00	0	0
Gi0/14	00.00.00.00.00.00	0	0
Gi0/15	00.00.00.00.00.00	0	0
Gi0/16	00.00.00.00.00.00	0	0
Ex0/1	00.00.00.00.00.00	0	0
Ex0/2	00.00.00.00.00.00	0	0
Ex0/3	00.00.00.00.00.00	0	0

Clicking the NEIGHBOR STATS tab brings up the LA NEIGHBOR STATISTICS INFORMATION page (Figure 7-186), which displays LACP neighbor statistics. The parameters for this page are shown in Table 7-154.

Table 7-154. LA Neighbor Statistics Information Page Parameters

Parameter	Description
Port Index	This parameter specifies the port index.
Partner SystemID	This parameter specifies the Partner SystemID.
Oper Key	This parameter specifies the Oper Key.
Partner Port Priority	This parameter specifies the Partner Port Priority.

## 802.1X

The 802.1x link allows you to view 802.1x statistics through the following pages:

- "802.1X Session Statistics" on page 7-215
- "802.1X Supplicant Statistics" on page 7-216
- "Mac Session Statistics" on page 7-217

### 802.1X Session Statistics

Figure 7-187. 802.1x Session Statistics Page

The screenshot shows the '802.1x Session Statistics' page for interface Gi0/1-Ex0/3. The page includes a navigation menu on the left with options like System Mgmt, Layer2 Mgmt, Layer3 Mgmt, Multicast, and Statistics. The main content area displays a table with the following data:

Port	Session ID	Received Frames	Transmitted Frames	Session Time (secs)	Session Terminate Cause	User Name
Gi0/1	1-0	0	0	105400	Admin Disabled	No User
Gi0/2	2-0	0	0	105400	Admin Disabled	No User
Gi0/3	3-0	0	0	105400	Admin Disabled	No User
Gi0/4	4-0	0	0	105400	Admin Disabled	No User
Gi0/5	5-0	0	0	105400	Admin Disabled	No User
Gi0/6	6-0	0	0	105400	Admin Disabled	No User
Gi0/7	7-0	0	0	105400	Admin Disabled	No User
Gi0/8	8-0	0	0	105400	Admin Disabled	No User
Gi0/9	9-0	0	0	105400	Admin Disabled	No User
Gi0/10	10-0	0	0	105400	Admin Disabled	No User
Gi0/11	11-0	0	0	105400	Admin Disabled	No User
Gi0/12	12-0	0	0	105400	Admin Disabled	No User
Gi0/13	13-0	0	0	105400	Admin Disabled	No User
Gi0/14	14-0	0	0	105400	Admin Disabled	No User
Gi0/15	15-0	0	0	105400	Admin Disabled	No User
Gi0/16	16-0	0	0	101100	Not Terminated Yet	No User
Ex0/1	25-0	0	0	105400	Admin Disabled	No User
Ex0/2	26-0	0	0	105400	Admin Disabled	No User
Ex0/3	27-0	0	0	101300	Not Terminated Yet	No User

Clicking the SESSION STATS tab brings up the 802.1X SESSION STATISTICS page (Figure 7-187), which displays 802.1x statistics information. The parameters for this page are shown in Table 7-155.

Table 7-155. 802.1x Session Statistics Page Parameters

Parameter	Description
Port	This parameter specifies the port index.
Session ID	This parameter specifies the session identifier.
Received Frames	This parameter specifies the number of packets received.
Transmitted Frames	This parameter specifies the number of packets transmitted.
Session Time (secs)	This parameter specifies the session time in seconds.

Table 7-155. 802.1x Session Statistics Page Parameters (Continued)

Parameter	Description
Session Terminate Cause	This parameter specifies the reason for session termination.
User Name	This parameter specifies the name of the user authenticated.

802.1X Supplicant Statistics

Figure 7-188. 802.1x Supplicant Session Statistics Page

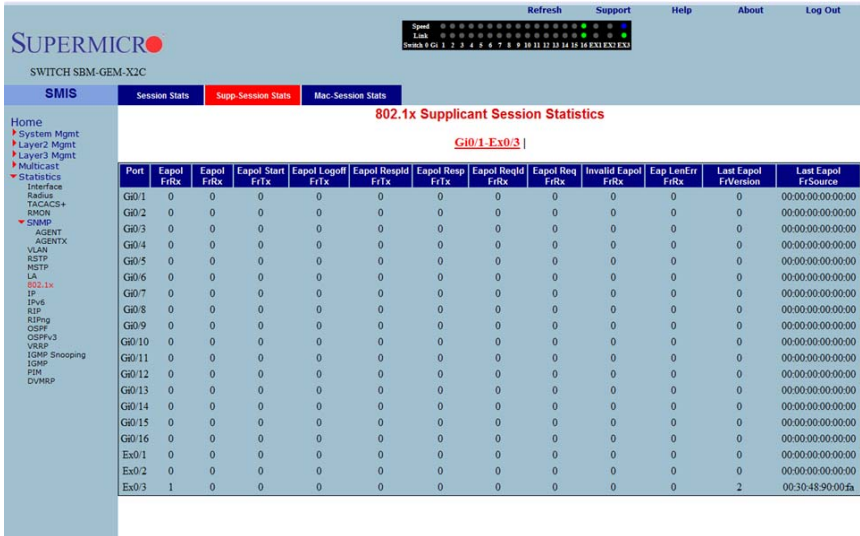

Clicking the SUPP SESSION STATS tab brings up the 802.1X SUPPLICANT SESSION STATISTICS page (Figure 7-188), which displays information about the 802.1x supplicant session. The parameters for this page are shown in Table 7-156.

Table 7-156. 802.1x Supplicant Session Statistics Page Parameters

Parameter	Description
Port	This parameter specifies the port index.
Eapol FrRx	This parameter specifies the number of the EAPOL packets received.
Eapol FrTx	This parameter specifies the number of the EAPOL packets transmitted.
Eapol Start FrTx	This parameter specifies the number of the EAPOL start packet transmitted.
Eapol Logoff FrTx	This parameter specifies the number of the EAPOL logoff packet transmitted.



**Table 7-156. 802.1x Supplicant Session Statistics Page Parameters (Continued)**

Parameter	Description
Eapol Respld FrTx	This parameter specifies the number of the EAPOL response identifier packet transmitted.
Eapol Resp FrTx	This parameter specifies the number of the EAPOL response packet frame transmitted.
Eapol Reqld FrRx	This parameter specifies the number of the EAPOL request identifier packet received.
Eapol Req FrRx	This parameter specifies the number of the EAPOL request frame received.
Invalid Eapol FrRx	This parameter specifies the number of the invalid EAPOL frame received.
Eap LenErr FrRx	This parameter specifies the number of EAPOL packets received with an invalid length.
Last Eapol FrVersion	This parameter specifies the version on the last EAPOL packet.
Last Eapol FrSource	This parameter specifies the source of the last EAPOL packet.

## Mac Session Statistics

**Figure 7-189. MAC Session Statistics Page**

The screenshot shows the 'MAC Session Statistics' page. At the top, there is a navigation bar with links for 'Refresh', 'Support', 'Help', 'About', and 'Log Out'. Below this, the page title 'MAC Session Statistics' is displayed. A search input field labeled 'Supplicant MacAddr' is present, along with a 'Submit' button. Below the input field, a dropdown menu is visible with the following options: 'Select', 'Supplicant MacAddr', 'Frames Rx', 'Frames Tx', 'Session ID', 'Session Terminate Cause', and 'User Name'. The page is part of a larger system interface with a navigation menu on the left and a top navigation bar with links for 'Refresh', 'Support', 'Help', 'About', and 'Log Out'.

Clicking the MAC SESSION STATS tab brings up the MAC SESSION STATISTICS page (Figure 7-189), which displays statistics information about 802.1x MAC sessions. The parameters for this page are shown in Table 7-157.

**Table 7-157. MAC Session Statistics Page Parameters**

<b>Parameter</b>	<b>Description</b>
Supplicant MacAddr	This parameter specifies the supplicant MAC address.
Frames Rx	This parameter specifies the number of packets received.
Frames Tx	This parameter specifies the number of packets transmitted.
Session ID	This parameter specifies the session identifier.
Session Terminate Cause	This parameter specifies the reason for session termination.
User Name	This parameter specifies the name of user authenticated.

## IP

The IP link allows you to view IP statistics through the following pages:

- "ARP Cache" on page 7-219
- "ICMP Statistics" on page 7-220

### ARP Cache

Figure 7-190. ARP Cache Page

The screenshot shows the ARP Cache page in the switch management interface. The page title is "ARP Cache". The interface includes a navigation menu on the left with options like Home, System Mgmt, Layer2 Mgmt, Layer3 Mgmt, Multicast, Statistics, Interface, Radius, TACACS+, RMON, SNMP, AGENT, AGENTX, VLAN, RSTP, MSTP, LLA, 802.1x, IP, IPv6, RIP, RIPv2, OSPF, OSPFv3, VRBP, ICMP Snooping, ICMP, PIM, and DVRRP. The main content area displays a table with the following data:

Interface	MAC Address	IP Address	Media Type
vlan1	00:1e:ec:cc:9a:14	192.168.100.125	Dynamic

Clicking the ARP CACHE tab brings up the ARP CACHE page (Figure 7-190), which displays ARP entries. The parameters for this page are shown in Table 7-158.

Table 7-158. ARP Cache Page Parameters

Parameter	Description
Interface	This parameter specifies the interface from which this ARP entry is learned.
MAC Address	This parameter specifies the MAC address.
IP Address	This parameter specifies the IP address.
Media Type	This parameter specifies the static ARP or dynamic ARP.

**ICMP Statistics**

**Figure 7-191. ICMP Statistics Page**

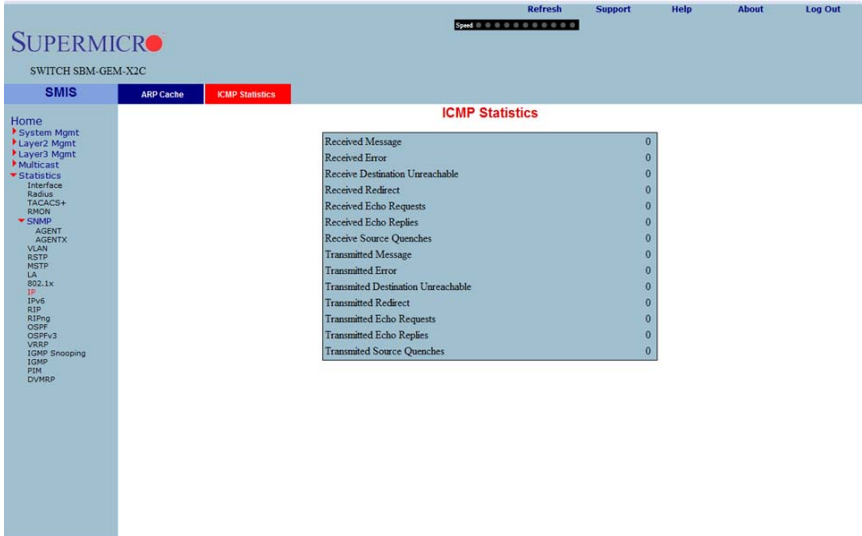

Clicking the ICMP STATISTICS tab brings up the ICMP STATISTICS page (Figure 7-191), which displays ICMP statistics information. The parameters for this page are shown in Table 7-159.

**Table 7-159. ICMP Statistics Page Parameters**

Parameter	Description
Received Message	This parameter specifies the number of received messages.
Received Error	This parameter specifies the number of received errors.
Receive Destination Unreachable	This parameter specifies the number of received destination unreachables.
Received Redirect	This parameter specifies the number of received redirects.
Received Echo Requests	This parameter specifies the number of echo requests..
Received Echo Replies	This parameter specifies the number of echo replies.
Receive Source Quenches	This parameter specifies the number of source quenches.
Transmitted Message	This parameter specifies the number of transmitted messages.
Transmitted Error	This parameter specifies the number of transmitted errors.
Transmitted Destination Unreachable	This parameter specifies the number of transmitted destination unreachables.
Transmitted Redirect	This parameter specifies the number of transmitted redirects.

**Table 7-159. ICMP Statistics Page Parameters (Continued)**

<b>Parameter</b>	<b>Description</b>
Transmitted Echo Requests	This parameter specifies the number of transmitted echo requests.
Transmitted Echo Replies	This parameter specifies the number of transmitted echo replies.
Transmitted Source Quenches	This parameter specifies the number of transmitted source quenches.

## IPv6

The IPv6 link allows you to view IPv6 statistics through the following pages:

- "IP V6 Interface Statistics" on page 7-222
- "ICMP V6 Statistics" on page 7-224

### IP V6 Interface Statistics

Figure 7-192. IPV6 Interface Statistics Page

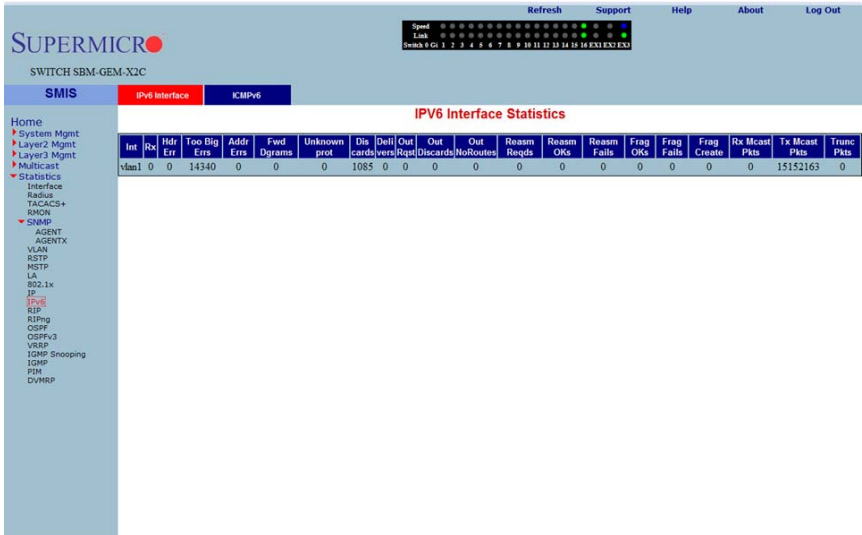

Clicking the IPV6 INTERFACE tab brings up the IPV6 INTERFACE STATISTICS page (Figure 7-192), which displays IPv6 port statistics. The parameters for this page are shown in Table 7-160.

Table 7-160. IPV6 Interface Statistics Page Parameters

Parameter	Description
Interface	This parameter specifies the Port index.
Rcvd	This parameter specifies the number of IPv6 packets received.
Hdr Err	This parameter specifies the number of IPv6 packets received with header error.
Too Big Errs	This parameter specifies the number of too big IPv6 packets received.
Addr Errs	This parameter specifies the number of IPv6 packets received with address errors.

Table 7-160. IPV6 Interface Statistics Page Parameters (Continued)

Parameter	Description
Fwd Dgrams	This parameter specifies the number of IPv6 datagrams forwarded in this port.
Unknown protos	This parameter specifies the number of packets received with unknown protocol.
Discdrs	This parameter specifies the number of received packets discarded due to errors.
Delivers	This parameter specifies the number of packets delivered.
Out Rqst	This parameter specifies the number of transmit requests.
Out Discards	This parameter specifies the number of transmit discards due to errors.
Out No Routes	This parameter specifies the number of packets to be transmitted but no routes.
Reasm Reqds	This parameter specifies the number of reassembly requests.
Reasm OKs	This parameter specifies the number of successful reassemblies.
Reasm Fails	This parameter specifies the number of reassemblies failed.
Frag OKs	This parameter specifies the number of good fragments received.
Frag Fails	This parameter specifies the number of fragments incompletely received.
Frag Creates	This parameter specifies the number of fragments created.
Rcvd Mcast Pkts	This parameter specifies the number of received IPv6 multicast packets.
Send Mcast Pkts	This parameter specifies the number of IPv6 multicast packets transmitted.
Trunctd Pkts	This parameter specifies the number of packets truncated.

## ICMP V6 Statistics

Figure 7-193. ICMPv6 Statistics Page

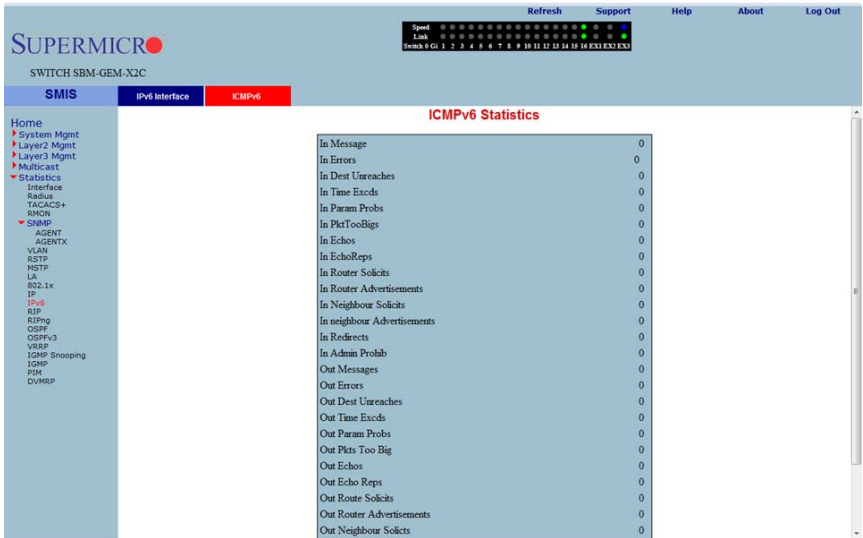

Clicking the ICMPv6 tab brings up the ICMPv6 STATISTICS page (Figure 7-193), which displays ICMPv6 statistics. The parameters for this page are shown in Table 7-161.

Table 7-161. ICMPv6 Statistics Page Parameters

Parameter	Description
In Message	This parameter specifies the number of messages received.
In Errors	This parameter specifies the number of messages received with errors.
In Dest Unreaches	This parameter specifies the number of destination unreachable messages received.
In Time Excds	This parameter specifies the number of receive timeouts.
In Param Probs	This parameter specifies the number of parameters probed.
In PktTooBigs	This parameter specifies the number of too big packets received.
In Echos	This parameter specifies the number of echo requests received.
In EchoReps	This parameter specifies the number of echo responses received.
In Router Solicits	This parameter specifies the number of received router solicit.
In Router Advertisements	This parameter specifies the number of routers advertisement received.
In Neighbor Solicits	This parameter specifies the number of received neighbor solicit.
In Neighbor Advertisements	This parameter specifies the number of received neighbor solicit.

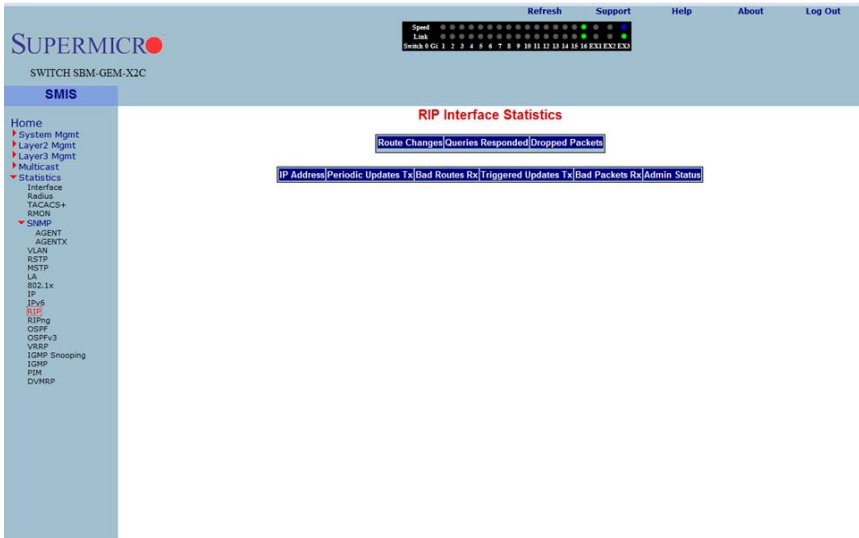

Table 7-161. ICMPv6 Statistics Page Parameters (Continued)

Parameter	Description
In Redirects	This parameter specifies the number of redirect packets received.
In Admin Prohib	This parameter specifies the number of receive admin prohibited.
Out Messages	This parameter specifies the number of messages transmitted.
Out Errors	This parameter specifies the number of messages transmitted with errors.
Out Dest Unreaches	This parameter specifies the number of destination unreachable messages transmitted.
Out Time Excds	This parameter specifies the number of transmit timeouts.
Out Param Probs	This parameter specifies the number of parameters probed.
Out Pkts Too Big	This parameter specifies the number of too big packets transmitted.
Out Echos	This parameter specifies the number of echo requests transmitted.
Out Echo Reps	This parameter specifies the number of echo responses transmitted.
Out Route Solicits	This parameter specifies the number of transmitted router solicits.
Out Router Advertisements	This parameter specifies the number of transmitted neighbor solicits.
Out Neighbour Solicits	This parameter specifies the number of transmitted neighbor solicits.
Out Neighbour Advertisements	This parameter specifies the number of transmitted neighbor solicits.
Out Redirects	This parameter specifies the number of redirect packets transmitted.
Out Admin Prohib	This parameter specifies the number of transmit admin prohibited.
In Bad Code	This parameter specifies the number of bad code packets.

## RIP Statistics

Figure 7-194. RIP Interface Statistics Page



Clicking the RIP link brings up the RIP INTERFACE STATISTICS page (Figure 7-194), which displays RIP statistics. The parameters for this page are shown in Table 7-162.

Table 7-162. RIP Interface Statistics Page Parameters

Parameter	Description
IP Address	This parameter specifies the IP address.
Received Bad Packets	This parameter specifies the number of received bad packets.
Received Bad Routes	This parameter specifies the number of received bad routes.
Transmitted Updates	This parameter specifies the the number of transmitted updates.

## RIP6

The RIP6 link allows you to view RIP6 statistics through the following pages:

- "RIP6 Interface Statistics" on page 7-227
- "RIP6 Route Information" on page 7-228

### RIP6 Interface Statistics

Figure 7-195. RIP6 Interface Statistics Page

The screenshot shows the SUPERMICR SWITCH SBM-GEM-X2C web interface. The main content area is titled "RIP6 Interface Statistics" and contains a table with the following columns: Interface ID, In Msg, In Req, In Resp, In Unk-Cmd, In Other-Ver, In Discards, Out Msg, Out Req, Out Resp, and TrigUpd. The left sidebar menu has "RIP6" highlighted. The top navigation bar includes "Refresh", "Support", "Help", "About", and "Log Out" buttons.

Clicking the INTERFACE STATISTICS tab brings up the RIP6 INTERFACE STATISTICS page (Figure 7-195), which displays RIPng statistics. The parameters for this page are shown in Table 7-163.

Table 7-163. RIP6 Interface Statistics Page Parameters

Parameter	Description
Interface ID	This parameter specifies the interface identifier.
In Msg	This parameter specifies the number of RIPng packets received.
In Req	This parameter specifies the number of RIPng request packets received.
In Resp	This parameter specifies the number of RIPng response packets received.
In Unk-Cmd	This parameter specifies the number of RIPng unknown command packets received.
In Other-Ver	This parameter specifies the number of RIPng other version packets received.

**Table 7-163. RIP6 Interface Statistics Page Parameters (Continued)**

Parameter	Description
In Discards	This parameter specifies the number of received packets discarded.
Out Msg	This parameter specifies the number of RIPng packets transmitted.
Out Req	This parameter specifies the number of RIPng request packets transmitted.
Out Resp	This parameter specifies the number of RIPng response packets transmitted.
Out TrigUpd	This parameter specifies the number of RIPng triggered updates transmitted.

**RIP6 Route Information**

**Figure 7-196. RIP6 Route Information Page**



Clicking the ROUTE INFORMATION tab brings up the RIP6 ROUTE INFORMATION page (Figure 7-196), which displays information about RIPng routes. The parameters for this page are shown in Table 7-164.

**Table 7-164. RIP6 Route Information Page Parameters**

Parameter	Description
Destination	This parameter specifies the route destination.
Prefix-len	This parameter specifies the length of the route prefix.

**Table 7-164. RIP6 Route Information Page Parameters (Continued)**

<b>Parameter</b>	<b>Description</b>
Protocol	This parameter specifies the routing protocol
Route-IfIndex	This parameter specifies the interface index.
Next-Hop	This parameter specifies the next hop for this route.
Route-Metric	This parameter specifies the metric of this route.
Route-Tag	This parameter specifies the route tag identifier.
Age	This parameter specifies the route age in seconds.

## OSPF

The OSPF link allows you to view OSPF statistics through the following pages:

- "OSPF Route Information" on page 7-230
- "OSPF Link State DB" on page 7-231

### OSPF Route Information

Figure 7-197. OSPF Route Information Page

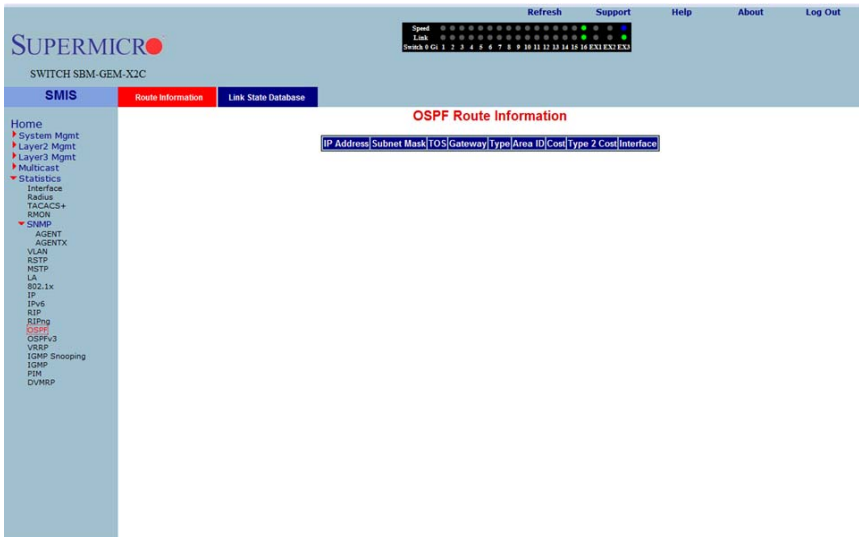

Clicking the ROUTE INFORMATION tab brings up the OSPF ROUTE INFORMATION page (Figure 7-197), which displays information about OSPF routes. The parameters for this page are shown in Table 7-165.

Table 7-165. OSPF Route Information Page Parameters

Parameter	Description
IP Address	This parameter specifies the IP address.
Subnet Mask	This parameter specifies the Subnet Mask.
TOS	This parameter specifies the TOS.
Gateway	This parameter specifies the gateway.
Type	This parameter specifies the type.
Area ID	This parameter specifies the Area ID.
Cost	This parameter specifies the cost.

Table 7-165. OSPF Route Information Page Parameters (Continued)

Parameter	Description
Type 2 Cost	This parameter specifies the Type 2 cost.
Interface	This parameter specifies the interface.

## OSPF Link State DB

Figure 7-198. OSPF Link State Database Page

Clicking the LINK STATE DATABASE tab brings up the OSPF LINK STATE DATABASE page (Figure 7-198), which displays information about OSPF link state database. The parameters for this page are shown in Table 7-166.

Table 7-166. OSPF Link State Database Page Parameters

Parameter	Description
Area ID	This parameter specifies the area identifier.
Type	This parameter specifies the link state type.
Link State ID	This parameter specifies the link state identifier.
Router ID	This parameter specifies the router identifier.
Sequence	This parameter specifies the sequence number of this link state information.

**Table 7-166. OSPF Link State Database Page Parameters (Continued)**

Parameter	Description
Checksum	This parameter specifies the checksum.
Age	This parameter specifies the link state information age in seconds.



## OSPFv3

The OSPFv3 link allows you to view OSPFv3 statistics through the following pages:

- "OSPFV3 Route Information" on page 7-233
- "OSPFV3 Link State DB" on page 7-234

### OSPFV3 Route Information

Figure 7-199. OSPFV3 Route Information Page

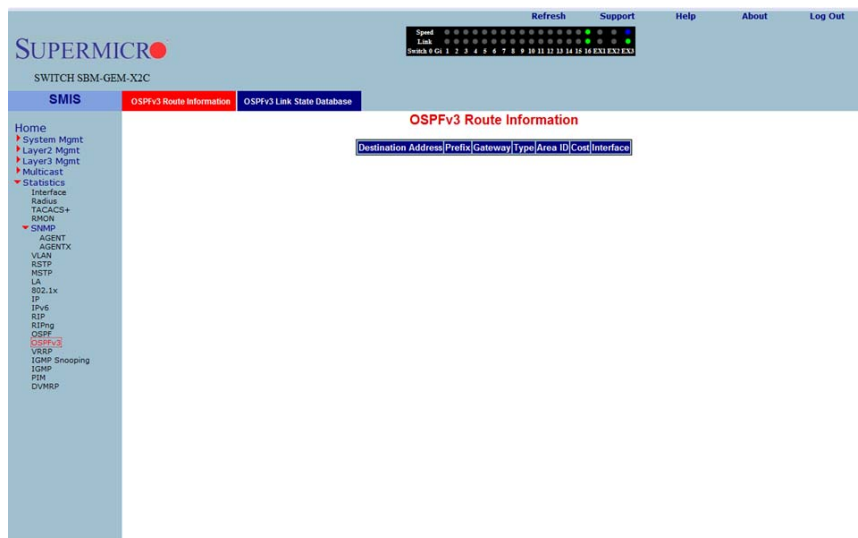

Clicking the OSPFV3 ROUTE INFORMATION tab brings up the OSPFV3 ROUTE INFORMATION page (Figure 7-199), which displays information about OSPFV3 routes. The parameters for this page are shown in Table 7-167.

Table 7-167. OSPFV3 Route Information Page Parameters

Parameter	Description
Destination Address	This parameter specifies the destination address.
Prefix	This parameter specifies the prefix.
Gateway	This parameter specifies the gateway.
Type	This parameter specifies the type.
Area ID	This parameter specifies the Area ID.
Cost	This parameter specifies the cost.
Interface	This parameter specifies the interface.

## OSPFV3 Link State DB

Figure 7-200. OSPFV3 Link State Database Page



Clicking the OSPFV3 LINK STATE DATABASE tab brings up the OSPFV3 LINK STATE DATABASE page (Figure 7-200), which displays information about OSPF link state database. The parameters for this page are shown in Table 7-168.

Table 7-168. OSPFV3 Link State Database Page Parameters

Parameter	Description
Area ID	This parameter specifies the area identifier.
Type	This parameter specifies the link state type.
Link State ID	This parameter specifies the link state identifier.
Router ID	This parameter specifies the router identifier.
Sequence	This parameter specifies the sequence number of this link state information.
Checksum	This parameter specifies the checksum.
Age	This parameter specifies the link state information age in seconds.

## VRRP Statistics

Figure 7-201. VRRP Statistics Page

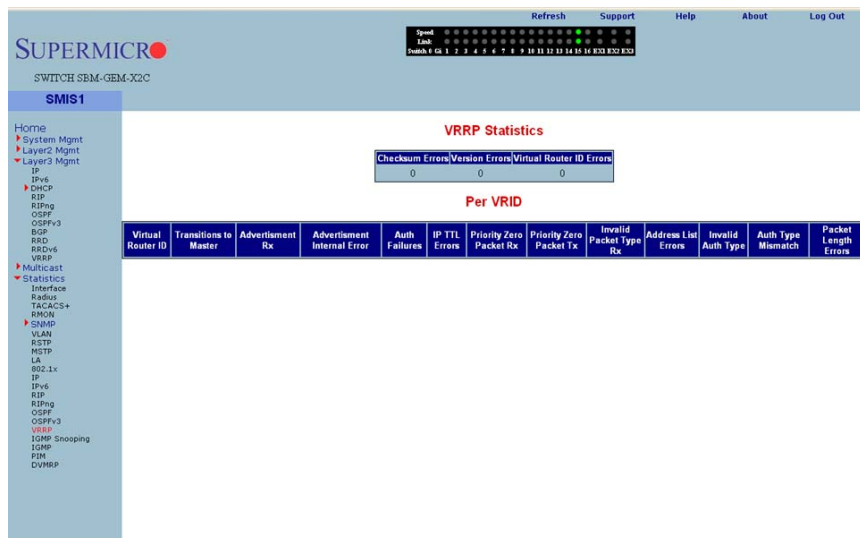

Clicking the VRRP link brings up the VRRP STATISTICS page (Figure 7-201), which displays VRRP global statistics and VRRP router specific statistics. The parameters for this page are shown in Table 7-169.

Table 7-169. VRRP Statistics Page Parameters

Parameter	Description
<b>VRRP Global Statistics</b>	
Checksum Errors	This parameter specifies the number of checksum errors.
Version Errors	This parameter specifies the number of version errors.
Virtual Router ID Errors	This parameter specifies the number of Virtual Router ID errors.
<b>VRRP Router Specific Statistics</b>	
Virtual Router ID	This parameter specifies the Virtual Router identifier.
Transitions to Master	This parameter specifies the number of transitions as Master.
Advertisement Receive	This parameter specifies the number of advertisement packets received.
Advertisement Internal Error	This parameter specifies the number of advertisement errors happened.
Authentication Failures	This parameter specifies the number of authentication failures.
IP TTL Errors	This parameter specifies the number of IP TTL errors happened.

**Table 7-169. VRRP Statistics Page Parameters (Continued)**

<b>Parameter</b>	<b>Description</b>
Priority Zero Packet Received	This parameter specifies the number of priority zero packets received.
Priority Zero Packet Transmitted	This parameter specifies the number of priority zero packets transmitted.
Invalid Packet Type Received	This parameter specifies the number of invalid packets received.
Address List Errors	This parameter specifies the number of address list errors.
Invalid Authentication Type	This parameter specifies the number of invalid authentication types received.
Authentication Type Mismatch	This parameter specifies the number of authentication type mismatch received.
Packet Length Errors	This parameter specifies the number of VRRP packets received with invalid length.

## IGMP Snooping

The IGMP link allows you to view IGMP statistics through the following pages:

- "IGMP Snooping Clear Statistics" on page 7-237
- "IGMP Snooping V1/V2 Statistics" on page 7-238
- "IGMP Snooping V3 Statistics" on page 7-239

### IGMP Snooping Clear Statistics

Figure 7-202. IGMP Snooping Clear Statistics Page

Clicking the IGS CLEAR STATS tab brings up the IGMP SNOOPING CLEAR STATISTICS page (Figure 7-202), which displays clearing IGMP snooping statistics. The parameters for this page are shown in Table 7-170.

Table 7-170. IGMP Snooping Clear Statistics Page Parameters

Parameter	Description
All	This parameter gives you the option to clear all the IGMP statistics.
Vlan ID	This parameter give you the option to clear IGMP statistics for a particular VLAN.

## IGMP Snooping V1/V2 Statistics

Figure 7-203. IGMP Snooping V1/V2 Statistics Page

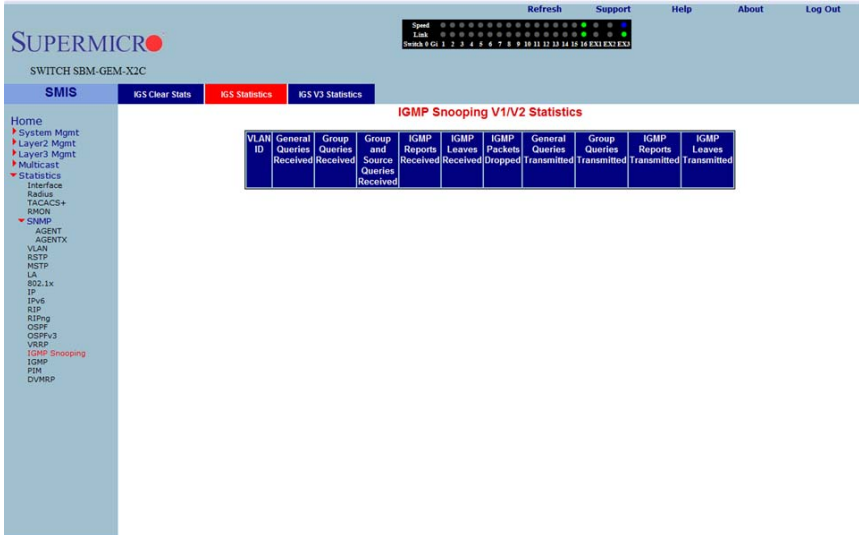

Clicking the IGS STATISTICS tab brings up the IGMP SNOOPING V1/V2 STATISTICS page (Figure 7-203), which displays IGMP snooping statistics. The parameters for this page are shown in Table 7-171.

Table 7-171. IGMP Snooping V1/V2 Statistics Page Parameters

Parameter	Description
VLAN ID	This parameter specifies the VLAN identifier.
General Queries Received	This parameter specifies the number of general query packets received.
Group Queries Received	This parameter specifies the number of group query packets received.
Group and Source Queries Received	This parameter specifies the number of group and source query packets received.
IGMP Reports Received	This parameter specifies the number of IGMP report packets received.
IGMP Leaves Received	This parameter specifies the number of IGMP leave packets received.
IGMP Packets Dropped	This parameter specifies the number of IGMP dackets dropped.
General Queries Transmitted	This parameter specifies the number of general query packets transmitted.
Group Queries Transmitted	This parameter specifies the number of group query packets transmitted.
IGMP Reports Transmitted	This parameter specifies the number of IGMP report packets transmitted.
IGMP Leaves Transmitted	This parameter specifies the number of IGMP leave packets transmitted.

## IGMP Snooping V3 Statistics

Figure 7-204. IGMP Snooping V3 Statistics Page

The screenshot shows the SUPERMICR web interface for a SWITCH SBM-GEM-X2C. The top navigation bar includes 'Refresh', 'Support', 'Help', 'About', and 'Log Out'. Below the navigation bar, there are tabs for 'SMIS', 'IGS Clear Stats', 'IGS Statistics', and 'IGS V3 Statistics'. The 'IGS V3 Statistics' tab is active, displaying the 'IGMP Snooping V3 Statistics' page. The page features a table with the following columns: VLAN ID, V3 Reports, IS\_INCL Messages Received, IS\_EXCL Messages Received, TO\_INCL Messages Received, TO\_EXCL Messages Received, ALLOW Messages Received, BLOCK Messages Received, and V3 Reports Sent. The table contains data for multiple VLANs, with the first row showing VLAN ID 1 and V3 Reports Received 1.

Clicking the IGS V3 STATISTICS tab brings up the IGMP SNOOPING V3 STATISTICS page (Figure 7-204), which displays IGMP snooping V3 statistics information. The parameters for this page are shown in Table 7-172.

Table 7-172. IGMP Snooping V3 Statistics Page Parameters

Parameter	Description
VLAN ID	This parameter specifies the VLAN identifier.
V3 Reports Received	This parameter specifies the number of Reports messages received.
IS_INCL Messages Received	This parameter specifies the number of messages received with is include field.
IS_EXCL Messages Received	This parameter specifies the number of messages received with is exclude field.
TO_INCL Messages Received	This parameter specifies the number of messages received with to include field.
TO_EXCL Messages Received	This parameter specifies the number of messages received with to exclude field.
ALLOW Messages Received	This parameter specifies the number of allow messages received.

**Table 7-172. IGMP Snooping V3 Statistics Page Parameters (Continued)**

Parameter	Description
BLOCK Messages Received	This parameter specifies the number of block messages received.
V3 Reports Sent	This parameter specifies the number of V3 reports transmitted.

## IGMP Statistics

**Figure 7-205. IGMP Route Statistics Page**

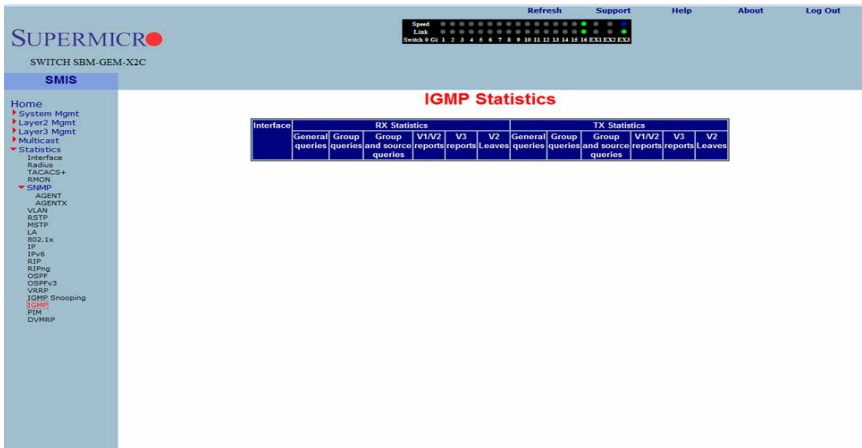

Clicking the IGMP link brings up the IGMP ROUTE STATISTICS page (Figure 7-205), which displays IGMP route information. The parameters for this page are shown in Table 7-173.

**Table 7-173. IGMP Route Statistics Page Parameters**

Parameter	Description
Interface	This parameter specifies the interface identifier.
General Queries Received	This parameter specifies the number of general query packets received.
Group Queries Received	This parameter specifies the number of group query packets received.
Group and Source Queries Received	This parameter specifies the number of group and source query packets received.
IGMP V1/V2 Reports Received	This parameter specifies the number of IGMP V1/V2 report packets received.



Table 7-173. IGMP Route Statistics Page Parameters (Continued)

Parameter	Description
IGMP V3 Reports Received	This parameter specifies the number of IGMP V3 report packets received.
General Queries Transmitted	This parameter specifies the number of general query packets transmitted.
Group Queries Transmitted	This parameter specifies the number of group query packets transmitted.
Group and Source Queries Transmitted	This parameter specifies the number of group and source query packets transmitted.

## PIM

The PIM link allows you to view PIM statistics through the following pages:

- "PIM Interface Statistics" on page 7-242
- "PIM Neighbor Statistics" on page 7-243
- "PIM BSR Info" on page 7-244
- "PIM RP Set Information" on page 7-245
- "PIM Route Information" on page 7-246

### PIM Interface Statistics

Figure 7-206. PIM Interface Statistics Page

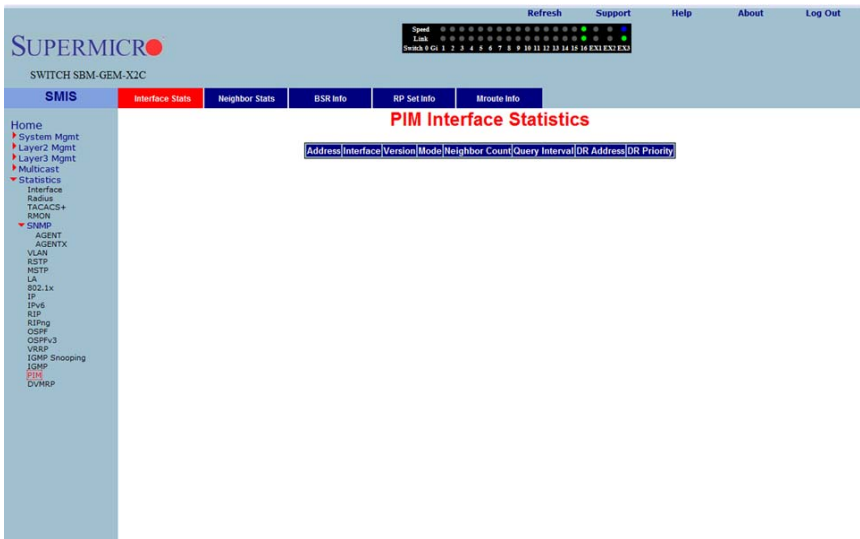

Clicking the INTERFACE STATS tab brings up the PIM INTERFACE STATISTICS page (Figure 7-206), which displays PIM interface statistics. The parameters for this page are shown in Table 7-174.

Table 7-174. PIM Interface Statistics Page Parameters

Parameter	Description
Address	This parameter specifies the address.
Interface	This parameter specifies the interface.
Version	This parameter specifies the version.
Mode	This parameter specifies the mode.

Table 7-174. PIM Interface Statistics Page Parameters (Continued)

Parameter	Description
Neighbor Count	This parameter specifies the neighbor count.
Query Interval	This parameter specifies the query interval.
DR address	This parameter specifies the DR address.
DR Priority	This parameter specifies the DR priority.

### PIM Neighbor Statistics

Figure 7-207. PIM Neighbor Statistics Page

The screenshot displays the 'PIM Neighbor Statistics' page within the Supermicr switch management interface. The page title is 'PIM Neighbor Statistics'. Below the title, a breadcrumb trail is visible: `Neighbor > Interface > Uptime > Expiry > Version > Priority > Mode > Component > Override > Interval > Lan Delay`. The interface includes a navigation menu on the left with categories like Home, System Mgmt, Layer 2 Mgmt, Layer 3 Mgmt, Multicast, and Statistics. The main content area is currently blank, showing only the breadcrumb trail.

Clicking the NEIGHBOR STATS tab brings up the PIM NEIGHBOR STATISTICS page (Figure 7-207), which displays PIM neighbor statistics. The parameters for this page are shown in Table 7-175.

Table 7-175. PIM Neighbor Statistics Page Parameters

Parameter	Description
Neighbor	This parameter specifies the neighbor.
Interface	This parameter specifies the interface.
Uptime	This parameter specifies the uptime.
Expiry	This parameter specifies the expiry.
Version	This parameter specifies the version.

**Table 7-175. PIM Neighbor Statistics Page Parameters (Continued)**

Parameter	Description
Priority	This parameter specifies the priority.
Mode	This parameter specifies the mode.
Component	This parameter specifies the component.
Override Interval	This parameter specifies the override interval.
LAN Delay	This parameter specifies the LAN delay.

**PIM BSR Info**

**Figure 7-208. PIM BSR Info Page**



Clicking the BSR INFO tab brings up the PIM BSR INFO page (Figure 7-208). The parameters for this page are shown in Table 7-176.

**Table 7-176. PIM BSR Info Page Parameters**

Parameter	Description
Component	This parameter specifies the component.
BSR	This parameter specifies the BSR.
BSR Address	This parameter specifies the BSR address.
Priority	This parameter specifies the priority.
Hash Mask Length	This parameter specifies the Hash Mask Length.

**PIM RP Set Information****Figure 7-209. PIM RP Information Page**

Clicking the RP SET INFO tab brings up the PIM RP INFORMATION page (Figure 7-209), which displays PIM RP information. The parameters for this page are shown in Table 7-177.

**Table 7-177. PIM RP Information Page Parameters**

Parameter	Description
Group	This parameter specifies the group address.
Mask	This parameter specifies the mask.
Candidate RP	This parameter specifies the candidate RP.
Hold Time	This parameter specifies the Hold time in seconds.
Expiry Time	This parameter specifies the expiry time in seconds.
Component	This parameter specifies the component identifier.

## PIM Route Information

Figure 7-210. PIM Route Information Page

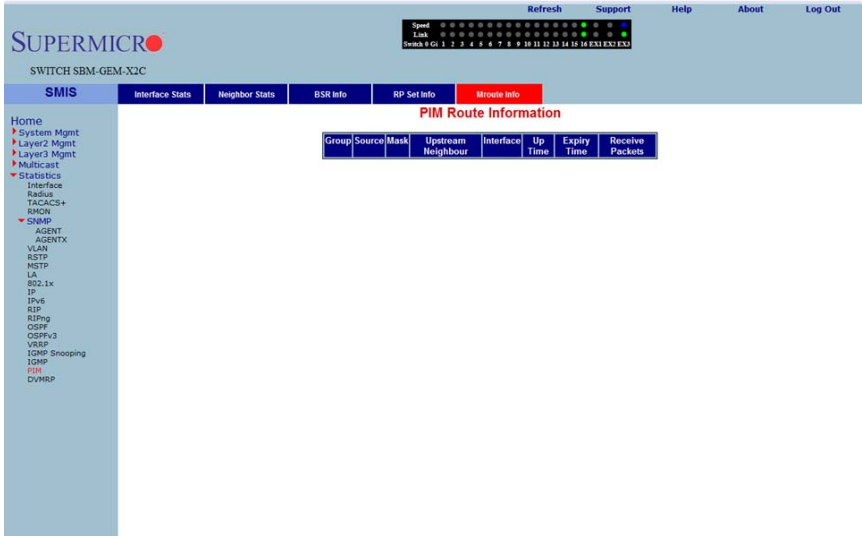

Clicking the MROUTE INFO tab brings up the PIM ROUTE INFORMATION page (Figure 7-210), which displays PIM route information. The parameters for this page are shown in Table 7-178.

Table 7-178. PIM Route Information Page Parameters

Parameter	Description
Group	This parameter specifies the group address.
Source	This parameter specifies the source address.
Mask	This parameter specifies the PIM route mask.
Upstream Neighbor	This parameter specifies the upstream neighbor address.
Interface	This parameter specifies the
Up Time	This parameter specifies the up time in seconds.
Expiry Time	This parameter specifies the expiry time in seconds.
Receive Packets	This parameter specifies the number of packets received.

## DVMRP

The DVMRP link allows you to view DVMRP statistics through the following pages:

- "DVMRP Routers" on page 7-247
- "DVMRP Multicast Routers" on page 7-248
- "DVMRP Prune Statistics" on page 7-249

### DVMRP Routers

Figure 7-211. DVMRP Routes Page

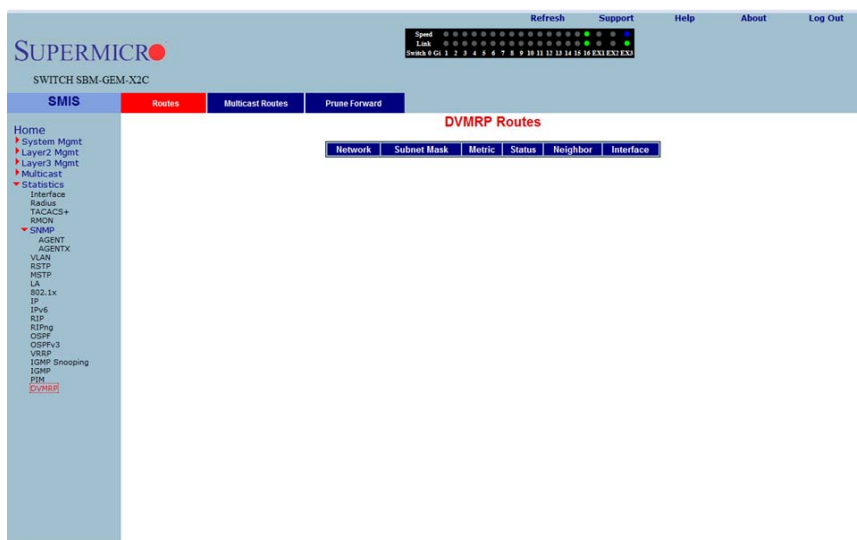

Clicking the ROUTES tab brings up the DVMRP ROUTES page (Figure 7-211), which displays DVMRP routes information. The parameters for this page are shown in Table 7-179.

Table 7-179. DVMRP Routes Page Parameters

Parameter	Description
Network	This parameter specifies the network address for this route.
Subnet Mask	This parameter specifies the network mask for this route.
Metric	This parameter specifies the metric value for this route.
Status	This parameter specifies the status of this route.
Neighbor	This parameter specifies the neighbor address for this route.
Interface	This parameter specifies the interface identifier.

## DVMRP Multicast Routers

Figure 7-212. DVMRP Multicast Routes Page

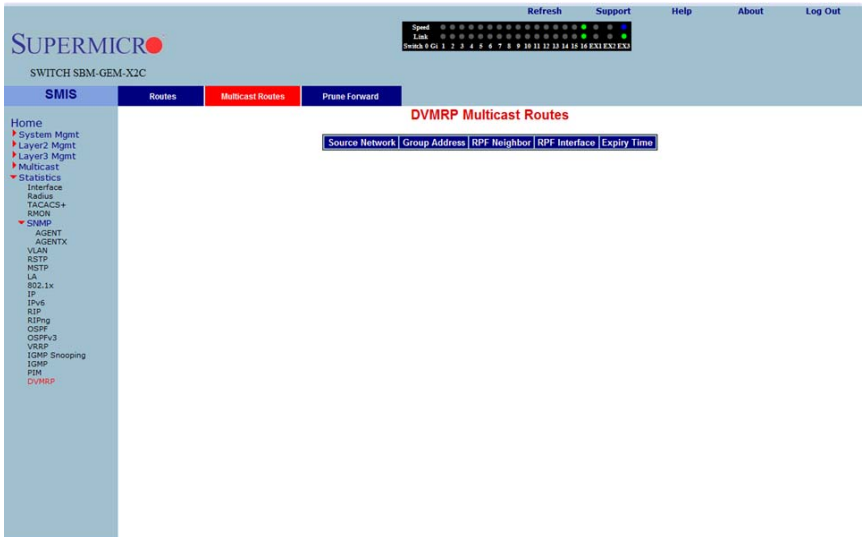

Clicking the MULTICAST ROUTES tab brings up the DVMRP MULTICAST ROUTES page (Figure 7-212), which displays DVMRP multicast routes information. The parameters for this page are shown in Table 7-180.

Table 7-180. DVMRP Multicast Routes Page Parameters

Parameter	Description
Source Network	This parameter specifies the source network.
Group Address	This parameter specifies the group address.
RPF Neighbor	This parameter specifies the RPF neighbor.
RPF Interface	This parameter specifies the RPF interface.
Expiry Time	This parameter specifies the expiry time in seconds.



**DVMRP Prune Statistics****Figure 7-213. DVMRP Prune Statistics Page**

Clicking the PRUNE FORWARD tab brings up the DVMRP PRUNE STATISTICS page (Figure 7-213), which DVMRP prune statistics information. The parameters for this page are shown in Table 7-181.

**Table 7-181. DVMRP Prune Statistics Page Parameters**

Parameter	Description
Source Network Address	This parameter specifies the source network address.
Group Address	This parameter specifies the group address.
Interface Identifier.	This parameter specifies the interface identifier.
Neighbor Address	This parameter specifies the neighbor address.
Time	This parameter specifies the time in seconds.

## Notes

---

---

# Appendix A

## HCA Mezzanine Cards

This appendix describes safety guidelines, features and installation of HCA Mezzanine cards used with the InfiniBand and 10-Gb switch module. See [Chapter 4](#) for further details on the InfiniBand module. See [Chapter 5](#) for further details on the 10-Gb switch module.

### A-1 Safety Guidelines

To avoid personal injury and property damage, carefully follow all the safety steps listed below when accessing your system or handling the components.

#### ESD Safety Guidelines

***Electric Static Discharge (ESD) can damage electronic components. To prevent damage to your system, it is important to handle it very carefully. The following measures are generally sufficient to protect your equipment from ESD.***

- Use a grounded wrist strap designed to prevent static discharge.
- Touch a grounded metal object before removing a component from the antistatic bag.
- Handle the add-on card by its edges only; do not touch its components, peripheral chips, memory modules or gold contacts.
- When handling chips or modules, avoid touching their pins.
- Put the card and peripherals back into their antistatic bags when not in use.

#### General Safety Guidelines

- Always disconnect power cables before installing or removing any components from the computer.
- Disconnect the power cable before installing or removing any cables from the system.
- Make sure that the add-on card is securely and properly installed on the motherboard to prevent damage to the system due to power shortage.

## A-2 Mezzanine HCA Cards

Available Mezzanine HCA cards for use with the SuperBlade InfiniBand switch are shown in the following sections.



**NOTE:** All images and layouts shown in this user's guide are based upon the latest PCB Revision available at the time of publishing. The card you have received may or may not look exactly the same as the graphics shown in this manual.

### AOC-IBH-001 Mezzanine HCA Card

The AOC-IBH-001 card has dual 4x DDR IB ports and uses a Mellanox Infinihost III Ex DDR chip. This card is no longer in production (EOL), but users of this card can consider replacement with the AOC-IBH-XDD Mezzanine HCA card as an alternative.

Figure A-1. AOC-IBH-001 Mezzanine HCA Card

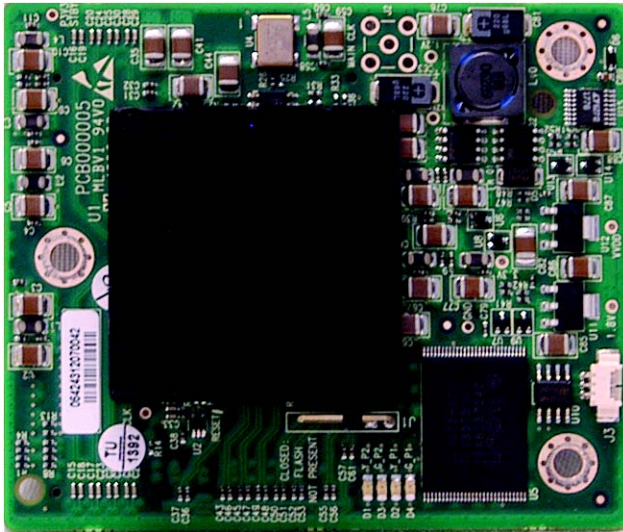

## AOC-IBH-002 Mezzanine HCA Card

The AOC-IBH-002 card has a single 4x DDR 20-Gbps IB port and uses a Mellanox InfiniHost III Lx DDR chip.

Figure A-2. AOC-IBH-002 Mezzanine HCA Card

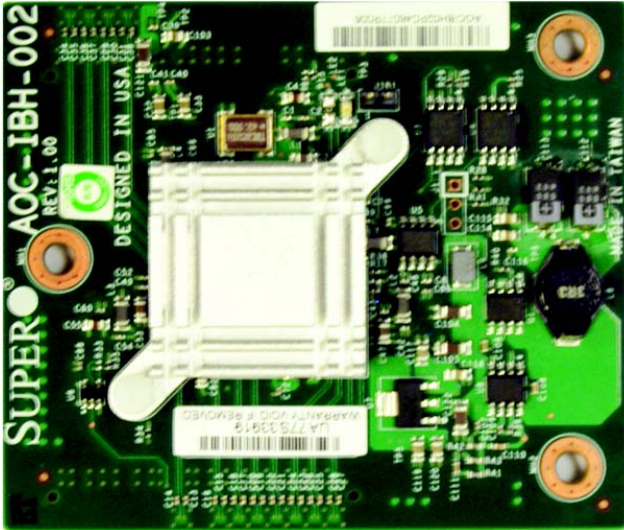

### AOC-IBH-003 Mezzanine HCA Card

The AOC-IBH-003 card has dual ports that can be either 4xDDR IB or 10-Gbps Ethernet and uses a Mellanox ConnectX chip. This card is no longer in production (EOL), but users of this card can consider replacement with the AOC-IBH-XDD Mezzanine HCA card as an alternative.

Figure A-3. AOC-IBH-003 Mezzanine HCA Card

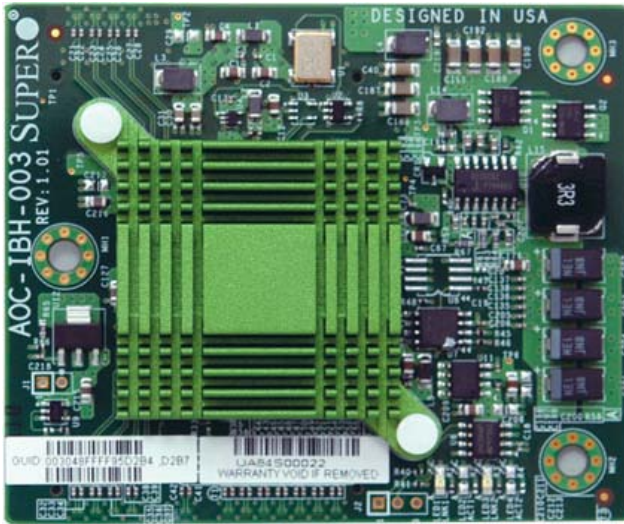

## AOC-IBH-XDS Mezzanine HCA Card

The AOC-IBH-XDS card has a single 4x DDR 20-Gbps port that can be either 4x DDR IB or 10-Gbps Ethernet and uses a Mellanox ConnectX chip. This card comes with a removable extender flange, like the one shown in [Figure A-6: "AOC-IBH-XQS Mezzanine HCA Card" on page A-7](#), that allows it to be installed in all compatible SuperBlade servers.

Figure A-4. AOC-IBH-XDS Mezzanine HCA Card

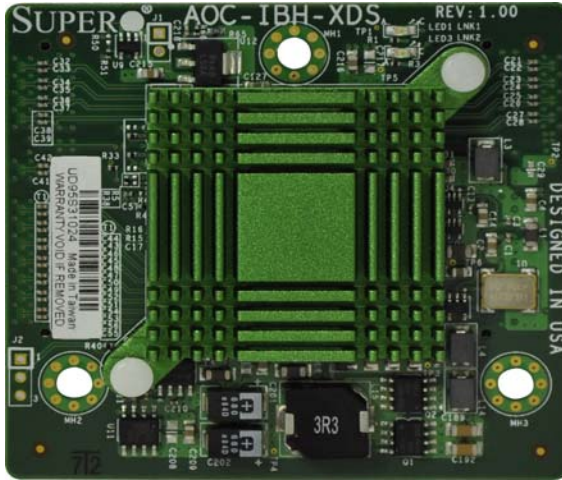

## AOC-IBH-XDD Mezzanine HCA Card

The AOC-IBH-XDD card has dual 4x DDR 20-Gbps ports that can be either 4x DDR IB or 10-Gbps Ethernet and uses a Mellanox ConnectX chip. This card comes with a removable extender flange, like the one shown in [Figure A-6: "AOC-IBH-XQS Mezzanine HCA Card" on page A-7](#), that allows it to be installed in all compatible SuperBlade servers.

Figure A-5. AOC-IBH-XDD Mezzanine HCA Card

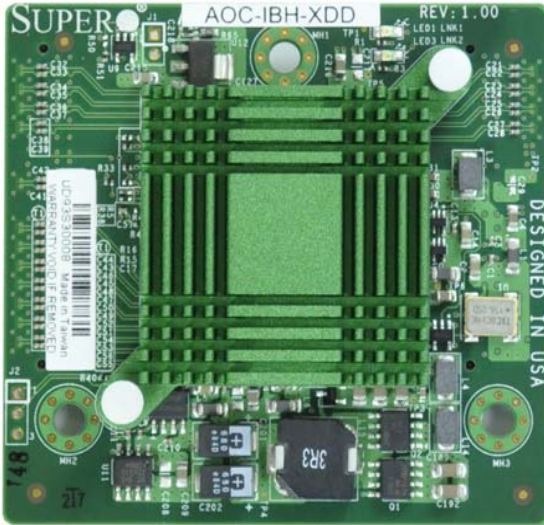



---

## AOC-IBH-XQS Mezzanine HCA Card

The AOC-IBH-XQS card has a single 4x QDR 40-Gbps port, and uses a Mellanox ConnectX chip. This card comes with a removable extender flange (shown in [Figure A-6](#)), that allows it to be installed in all compatible SuperBlade servers.

Figure A-6. AOC-IBH-XQS Mezzanine HCA Card

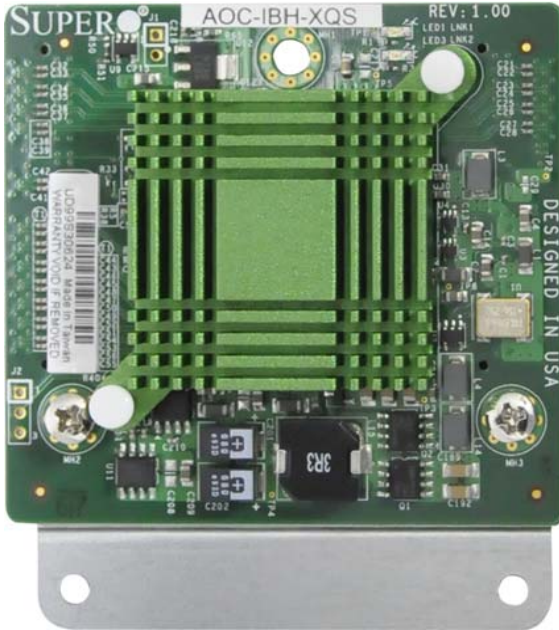

### AOC-IBH-XQD Mezzanine HCA Card

The AOC-IBH-XQS card has dual 4x QDR 40-Gbps ports, and uses a Mellanox ConnectX chip. This card comes with a removable extender flange (like the one shown in [Figure A-6: "AOC-IBH-XQS Mezzanine HCA Card" on page A-7](#)), that allows it to be installed in all compatible SuperBlade servers.

Figure A-7. AOC-IBH-XQD Mezzanine HCA Card

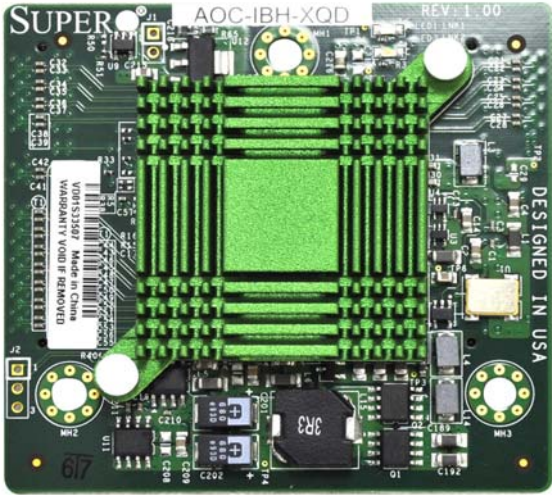

---

---

## AOC-XEH-iN2 Mezzanine HCA Card

The AOC-XEH-iN2 card has dual 10-Gbps Ethernet ports, and uses an Intel® 82599 (Niantic™) chip. This card comes with a removable extender flange (like the one shown in [Figure A-6: "AOC-IBH-XQS Mezzanine HCA Card" on page A-7](#)), that allows it to be installed in all compatible SuperBlade servers.

This mezzanine card can be used as a 10-Gbps Ethernet NIC with either the SBM-XEM-002/M 10-Gbps Ethernet pass-through or the SBM-XEM-X10SM 10-Gbps Ethernet switch.

**Figure A-8. AOC-XEH-iN2 Mezzanine HCA Card**

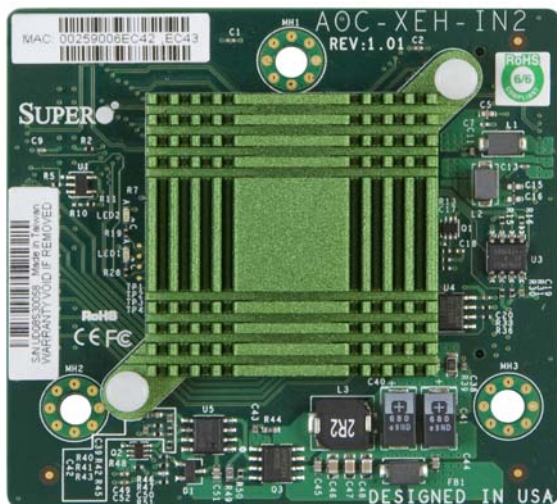

### A-3 Installation

Figure A-9. Installation Location

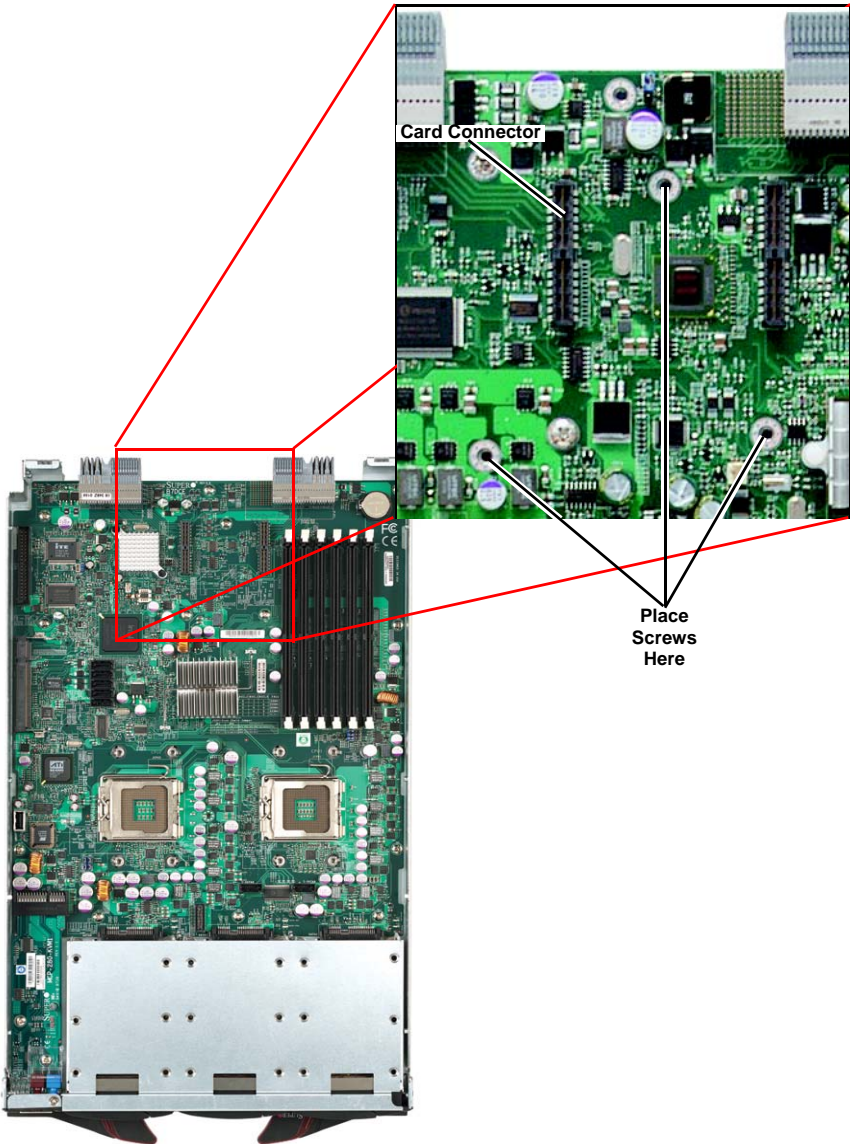

---

---

## ***Installation Location***

All models of the Mezzanine HCA card are compatible with both SBI and SBA blade modules. The AOC-IBH-XQS and AOC-IBH-XQD cards are only compatible with the latest SBI and SBA models. For the latest compatibility information, see our web site:

<http://www.supermicro.com/products/superblade/>

## **Card Installation**

### ***To Install an HCA Card:***

1. Confirm that you have the correct card and three (3) screws.
2. Following the instructions from the SuperBlade Manual, remove the blade module and open the cover to access the mainboard.
3. In a standard, electro-magnetically protected workstation, secure the card to the serverboard by gently but firmly attaching the card to the two connectors.
4. Using a Phillips screw driver, secure and tighten each screw one at a time. Do not overtighten the screws.



**NOTE:** The latest models of the Supermicro InfiniBand HCA card have a smaller form factor to make them compatible with newer blade modules. The newer HCAs come from the factory with an extender bracket attached to allow installation in older blade modules.

For installation in newer blade modules, first remove the extender bracket by removing the two screws with a Phillips screwdriver. Then follow the above instructions for installation on the blade module itself.

**Figure A-10. Card Installation**

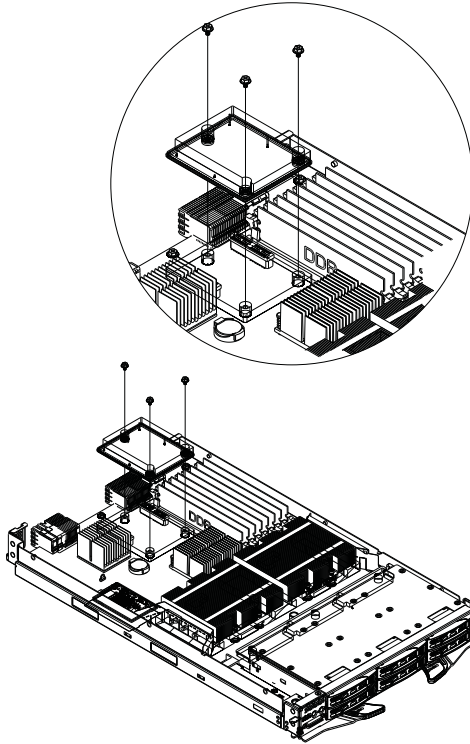

**Figure A-11. Installation Complete**

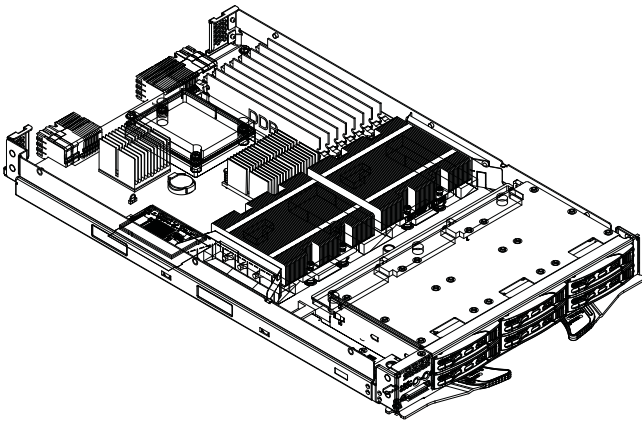

---

---

# Appendix B

## LED Descriptions

This appendix covers LED descriptions for the blade enclosure and other module components. The LED descriptions for the InfiniBand switch, Gigabit Ethernet modules and Blade modules are included here for your reference.

### B-1 Gigabit Ethernet Module LED Descriptions

SBM-GEM-001 Gigabit Ethernet module and SBM-GEM-002 Pass-through module LEDs are described below in [Table B-1](#).

**Table B-1. Gigabit Ethernet Switch LED Indicators**

LED	State	Description
Module Initiation OK LED (GEM-001 Module Only)	Steady On	The GEM-001 GbE switch module is operational and has passed the POST (Power-On Self-Test) with no critical faults.
Module Fault LED (Red) (GEM-001 Module Only)	Steady On	When lit, this LED indicates that the GEM-001 GbE switch module has either failed the POST or has detected an operational fault within the module. When this LED is lit, the fault LED on the blade enclosure will also turn on.
Link/Activity Ethernet Port Status LED	Solid Green	This indicates that the link is established, no activity
	Blinking Green	This indicates that data is being transmitted (Tx) or received (Rx)
	Off	This indicates that no link is established
Speed Ethernet Port Status LED (GEM-001 Module Only)	Amber	Connection speed of the port is 1 Gb/sec
	Green	Connection speed of the port is 100 Mb/sec
	Off	Connection speed of the port is 10 Mb/sec

## B-2 1/10 Gigabit Ethernet Module LED Descriptions

The SBM-GEM-X2C/+ 1/10 Gbps Ethernet module and XEM-002 10GbE Pass-through Module LEDs are described below in [Table B-2](#).

**Table B-2. 1/10 Gigabit Ethernet Switch LED Indicators**

LED	State	Description
RJ45 Link/Activity (GEM-X2C Module Only)	Green	Solid denotes link established, no activity. Blinking denotes activity. Off indicates that no link is established.
RJ45 Speed (GEM-X2C Module Only)	Amber/Green/ Off	Amber denotes 1 Gbps speed. Green denotes 100 Mbps speed. Off denotes 10 Mbps speed.
"Initiation OK" LED	Blue	Denotes successful initiation/OK status when solidly lit.
Module Fault LED	Red	Denotes SBM-GEM-X2C module failure when solidly lit.
10G Port LEDs	Green	Denotes activity for 10Gbps port when solidly lit. Blinking green denotes data transmitted (Tx) or received (Rx).
Stack ID LEDs (GEM-X2C Module Only)	Green	Denotes Stack ID activity as shown in <a href="#">Table B-3</a> below.

**Table B-3. Stacking LED Activity (SBM-GEM-X2C/+ Only)**

Stack LED 4	Stack LED 3	Stack LED 2	Stack LED 1	Stacking Switch Identifier
OFF	OFF	OFF	ON	1
OFF	OFF	ON	OFF	2
OFF	OFF	ON	ON	3
OFF	ON	OFF	OFF	4
OFF	ON	OFF	ON	5
OFF	ON	ON	OFF	6
OFF	ON	ON	ON	7
ON	OFF	OFF	OFF	8
ON	OFF	OFF	ON	9
ON	OFF	ON	OFF	10
ON	OFF	ON	ON	11
ON	ON	OFF	OFF	12
ON	ON	OFF	ON	13
ON	ON	ON	OFF	14
ON	ON	ON	ON	15
OFF	OFF	OFF	OFF	16 / Stacking Disabled.



## B-3 SBM-XEM-X10SM 10G and SBM-XEM-F8X4SM Ethernet Switch LED Descriptions

SBM-XEM-X10SM and SBM-XEM-F8X4SM10-Gigabit Ethernet switch module LEDs are found below in [Table B-6](#).

**Table B-4. SBM-XEM-X10SM Ethernet Switch LEDs**

LED	State	Indication Description
10G Port LED (left) Link Up/Available	Off	Port is not available
	Amber	Port is available and link down
	Green	Link up
10G Port LED (right) Link speed/Activity	Off	No activity
	Amber Blink	Speed 1G activity
	Green Blink	Speed 10G activity
Switch Fault Indicator	Off	Switch is in normal operation
	Red	Switch is failed
Switch Available Indicator	Off	Switch firmware is in initialization state.
	Green	Switch firmware INIT OK and ready.
CMM Available Indicator	Off	CMM is not active
	Blue blink	CMM is active
RJ45 1G Switch Port (left)	OFF	Link down, no activity
	Solid Green	Link up
	Green blink	Activity
RJ45 1G Switch Port (right)	Off	Speed 10Mbps
	Green	Speed 100Mbps
	Amber	Speed 1000Mbps
RJ45 CMM Port (left)	Off	No activity
	Green blink	Activity
RJ45 CMM Port (right)	Off	Link down
	Green	Speed 100/10Mbps
	Amber	Speed 1000Mbps

## B-4 SBM-IBS-001 InfiniBand Switch LED Descriptions

SBM-IBS-001 InfiniBand switch module LEDs are found below in [Table B-5](#).

**Table B-5. SBM-IBS-001 InfiniBand Switch LEDs**

LED	State	Indication Description
Module Status LED	Blink	Switch is booting its firmware
	Steady On	Boot process failed
	Off	Switch is properly booted and operational
Module Power LED (Green)	Steady On	Switch has power and is operational
	Off	There is a problem with the power being supplied to the switch.
Port Physical Link LED (Green)	Steady On	Physical link established
	Blink	Physical link error, poor connection quality
	Off	Port is off or has no physical connection
Port Activity LED (Yellow)	Steady On	Logic link established, no activity
	Blinking	Data transferring to/from the port
	Off	Logical link is down

## B-5 SBM-IBS-Q3616M and SBM-IBS-Q3618M InfiniBand Switch LED Descriptions

SBM-IBS-Q3616M and SBM-IBS-Q3618M InfiniBand switch module LEDs are found below in [Table B-6](#).

**Table B-6. SBM-IBS-Q3616M and SBM-IBS-Q3618M InfiniBand Switch LEDs**

LED	State	Indication Description
Module Status LED (Red)	On	Failure
	Off	Error
Module Power LED (Green)	Steady On	Switch has power and is operational
	Off	There is a problem with the power being supplied to the switch
Port Physical Link LED (Green)	Steady On	Physical link established
	Blink	Physical link error, poor connection quality
	Off	Port is off or has no physical connection
Port Activity LED (Yellow)	Steady On	Logic link established, no activity
	Blinking	Data transferring to/from the port
	Off	Logical link is down
CMM (Blue) M Models Only	Blinking	CMM has power is operational
	Off	No CMM or CMM is not available

## Notes

---

# Appendix C

## Installing Triple Wide Bays

This appendix describes the setup for triple-wide module bays used by the InfiniBand pass-through module. See [Chapter 4](#) for further details on InfiniBand modules.

### C-1 Installing a Triple Wide Module Bay

Use the procedure below for installing a triple-wide module bay in a Superblade chassis.

#### *Installing a Triple-Wide Module Bay*

1. Remove the four screws that secure the inner enclosure to the main enclosure.  
Slide the inner enclosure outward, depressing the locking tabs on both sides to pull it completely out.
2. Remove any single-wide modules that are occupying the bays you wish to modify to a triple-wide bay. See [Figure C-1, Step 1 & 2](#) for details.

Figure C-1. Step 1 & 2

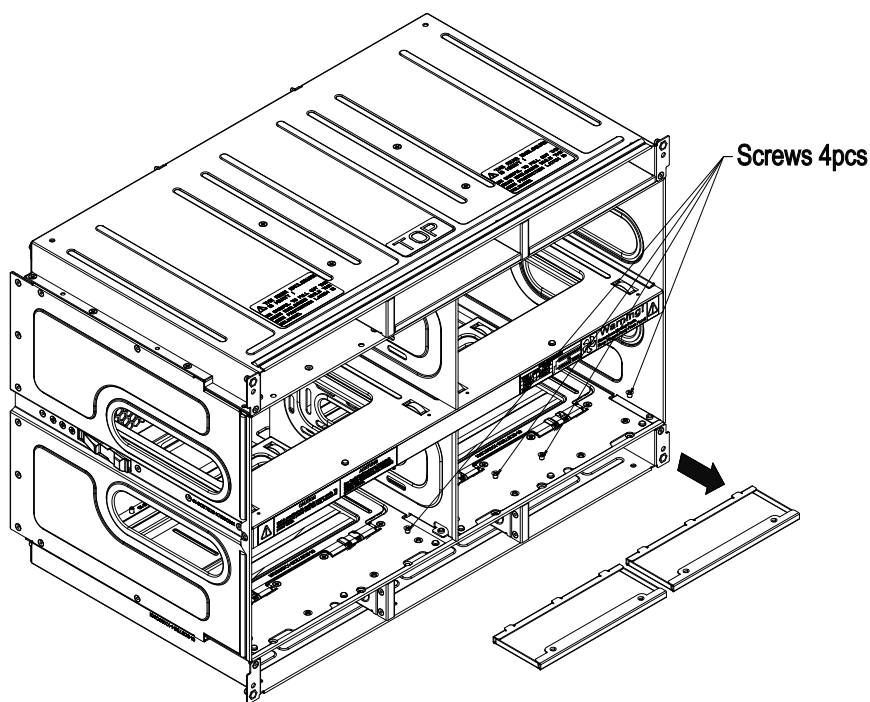

3. In the module bay you wish to expand to triple wide, remove the two screws that secure the center support to the inner enclosure then take out the center support.
4. Remove the two screws from the underside of each of the two horizontal spacers. See [Figure C-2, Step 3 & 4](#) for details.

Figure C-2. Step 3 & 4

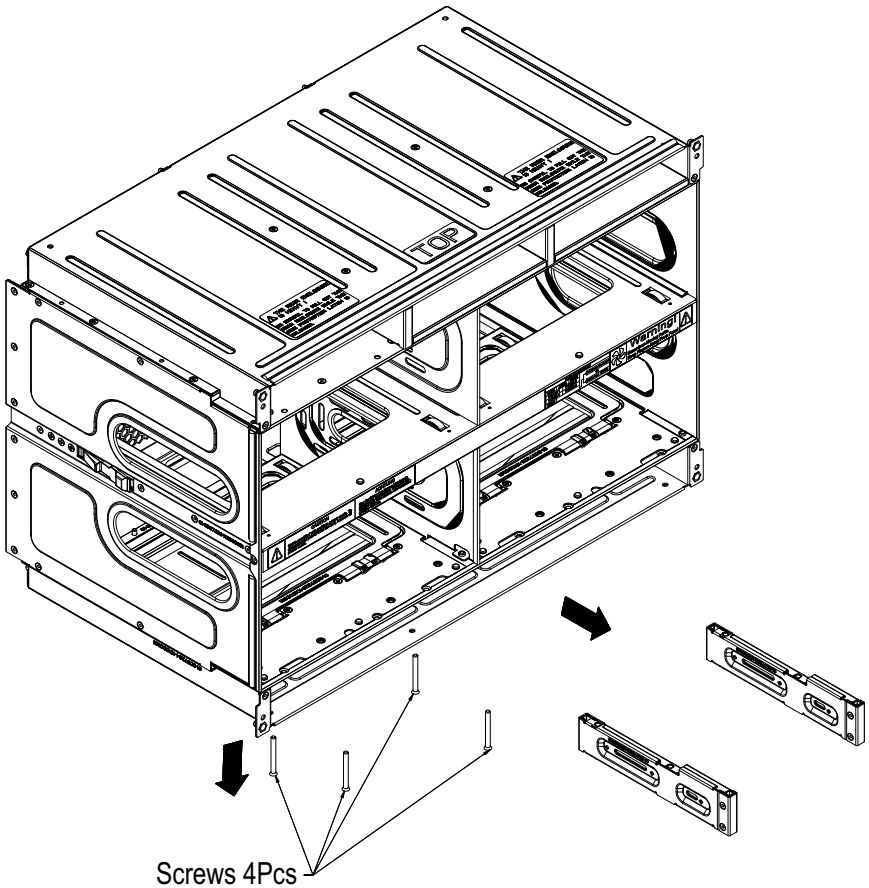

5. Using four screws, install the long horizontal spacer to the same space where the two short spacers were removed. See [Figure C-3, Step 5](#) for details.

Figure C-3. Step 5

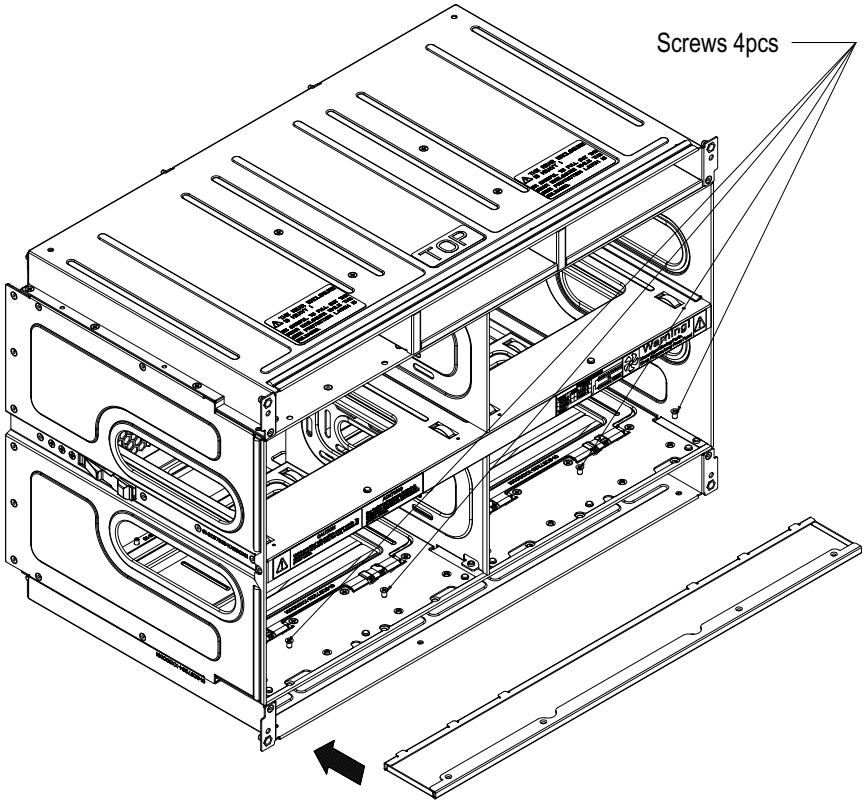

6. You can now install a double-wide module into the bay. See [Figure C-4, Step 6](#) for details.

Figure C-4. Step 6

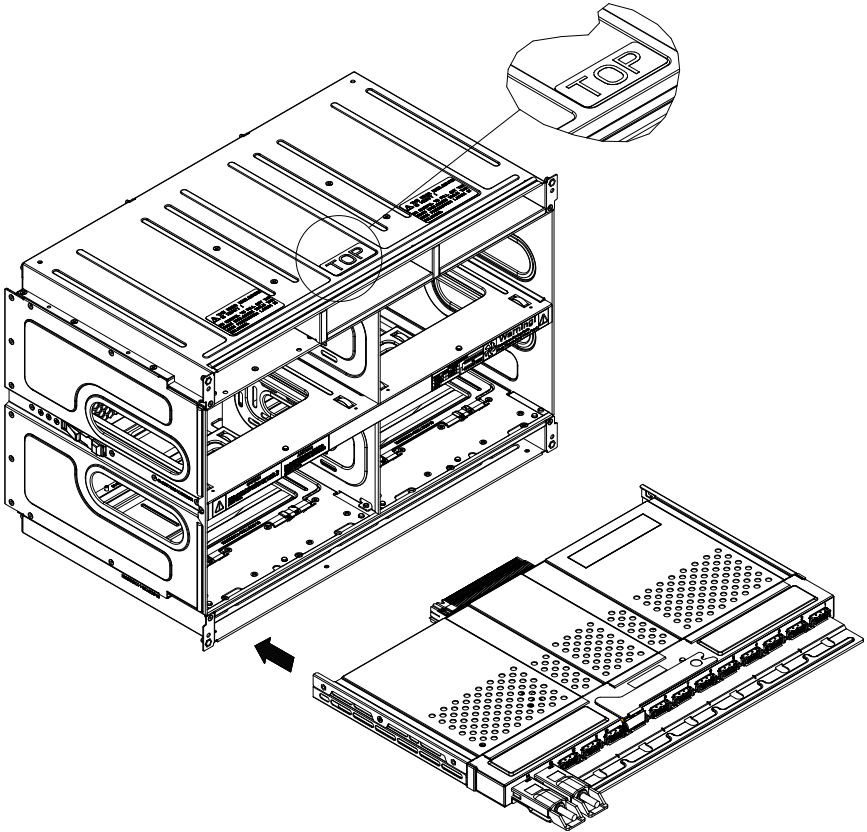

**NOTE:** This procedure describes modifying three right most single-wide bays located at the bottom of the inner enclosure. The same procedure applies to the three right most single bays located at the top of the enclosure, but note that the horizontal spacers in the bottom bays use a guide pin and are not interchangeable with the upper bay spacers.

Modules in the upper bays will have their release handles on the bottom, while modules in the lower bays will have their release handles on the top.

*Placing modules in an “upside-down” orientation in an upper-bay (only) does not affect their operation.*





**NOTE:** Only one triple-wide module can be installed in an enclosure since each enclosure requires at least one CMM module. The bottom location is recommended.

If using the AOC-IBH-002 single-port InfiniBand mezzanine card, the InfiniBand pass-through module *MUST* be installed in the bottom location.

## Notes

---

---

# Disclaimer

The products sold by Supermicro are not intended for and will not be used in life support systems, medical equipment, nuclear facilities or systems, aircraft, aircraft devices, aircraft/emergency communication devices or other critical systems whose failure to perform be reasonably expected to result in significant injury or loss of life or catastrophic property damage. Accordingly, Supermicro disclaims any and all liability, and should buyer use or sell such products for use in such ultra-hazardous applications, it does so entirely at its own risk. Furthermore, buyer agrees to fully indemnify, defend and hold Supermicro harmless for and against any and all claims, demands, actions, litigation, and proceedings of any kind arising out of or related to such ultra-hazardous use or sale.

---

